

FINAL ENGINEERING REPORT ON  
RADIO RECEIVERS R-389( )/URR AND R-390( )/URR

September 15, 1953

Object: Development of Low and Medium Frequency Radio Receivers

Signal Corps Contract No. W36-039-sc-44552

Signal Corps Specification - SCL-1134-B

Department of the Army Project No. 3-24-01-051

Signal Corps Project No. 15-805G-2

Placed by U.S. Army, Signal Corps Engineering Laboratories,  
Fort Monmouth, New Jersey

This document contains information affecting the national defense of the United States within the meaning of the Espionage Laws, Title 18, U.S.C., Sections 793 and 794. The transmission or the revelation of its contents in any manner to an unauthorized person is prohibited by law.

PREPARED BY:

APPROVED BY:

L. W. Couillard  
Project Engineer

[Signature]  
Director of Engineering  
and Research Division

A PUBLICATION OF  
THE RESEARCH AND DEVELOPMENT LABORATORIES  
COLLINS RADIO COMPANY  
Cedar Rapids, Iowa

RESTRICTED

Courtesy of <http://BlackRadios.terryo.org>

## TABLE OF CONTENTS

<u>Sections</u>	<u>Title</u>	<u>Page</u>
1.0	Purpose . . . . .	1
2.0	Abstract . . . . .	1
3.0	Publications . . . . .	4
4.0	Factual Data . . . . .	4
5.0	Conclusions . . . . .	78
6.0	Recommendations . . . . .	79
7.0	Identification of Personnel .	80

LIST OF ILLUSTRATIONS

<u>Figure</u>	<u>Title</u>	<u>Page</u>
1	Typical Frequency Systems	
2	Radio Receiver R-389/URR Final Mixing Diagram	
3	Radio Receiver R-390/URR Block Diagram of R-F Unit	
4	Radio Receiver R-389/URR Front View	
5	Radio Receiver R-390/URR Front View	
6	Radio Receiver R-389/URR Rear View	
7	Radio Receiver R-389/URR Top View - Shield Removed	
8	Radio Receiver R-389/URR Bottom View	
9	Radio Receiver R-389/URR Front View - Panel Removed	
10	Radio Receiver R-389/URR Front View - Unit Removed	
11	Radio Receiver R-389/URR Bottom View - Unit Removed	
12	Radio Receiver R-389/URR R-F Unit - Rear View	
13	Radio Receiver R-389/URR R-F Unit - Bottom View	
14	Radio Receiver R-389/URR Gear Train	
15	Radio Receiver R-389/URR R-F Coil	
16	Radio Receiver R-390/URR Rear View	
17	Radio Receiver R-390/URR Top View	
18	Radio Receiver R-390/URR Top View - Shield Removed	
19	Radio Receiver R-390/URR Bottom View	
20	Radio Receiver R-390/URR Front Panel Removed	
21	Radio Receiver R-390/URR Panel and Units Removed	
22	Radio Receiver R-390/URR Bottom View - Units Removed	
23	A-C Power Supply - Top View	
24	A-C Power Supply - Bottom View	
25	28 Volt D-C Power Unit	
26	Audio Unit - Top View	
27	Audio Unit - Bottom View	
28	I-F Unit - Top View	
29	I-F Unit - Bottom View	
30	B.F.O. Unit	
31	I-F Coil	
32	Crystal Filter	
33	Antenna Relay Unit	
34	Antenna Relay - Cover Removed	
35	Radio Receiver R-390/URR R-F Unit - Oblique View	
36	Radio Receiver R-390/URR R-F Unit - Rear View	
36A	Radio Receiver R-390/URR R-F Unit - Bottom View	

Courtesy of <http://BlackRadios.terryo.org>

## LIST OF ILLUSTRATIONS (Cont.)

<u>Figure</u>	<u>Title</u>	<u>Page</u>
37	Radio Receiver R-390/URR R-F Chassis	
38	Radio Receiver R-390/URR R-F Gear Train	
39	Radio Receiver R-390/URR Antenna Coil	
40	Radio Receiver R-390/URR R-F Coil	
41	Crystal Oscillator - Top View	
42	Crystal Oscillator - Oven Removed	
43	Calibrator Unit - Top View	
44	Calibrator Unit - Bottom View	
45	Radio Receiver R-389/URR VFO	
46	Radio Receiver R-389/URR VFO - Cover Removed	
47	Radio Receiver R-390/URR VFO	
48	Radio Receiver R-390/URR VFO - Cover Removed	
49	Table Cabinet	
50	Table Cabinet - Collapsed	
51	A-C Power Diagram	
52	Dynamotor Filter Circuit	
53	115 Volt D-C Inverter	
54	115 Volt D-C Rotary Supply	
55	Line Audio Circuits	
56	Audio Response Curves	
57	I-F Unit Block Diagram	
58	I-F Transformers	
59	Crystal Filter Circuit	
60	Interstage I-F Transformer	
61	Radio Receiver R-389/URR Trial Mixing Diagrams	
62	Radio Receiver R-389/URR Trial Mixing Diagrams	
63	Radio Receiver R-390/URR Antenna Input Circuit	
64	Second Crystal Oscillator	
65	Crystal Oscillator Coil	
66	AGC Circuit	
67	Carrier Meter Circuit	
68	Radio Receiver R-390/URR VFO Temperature Curve	
69	Noise Limiter Circuit	
70	Radio Receiver R-390/URR VFO Transformer	
71	Radio Receiver R-389/URR Mechanical System	
72	Radio Receiver R-390/URR Mechanical System	
73	Radio Receiver R-389/URR Schematic	
74	Radio Receiver R-390/URR Schematic	



Courtesy of <http://BlackRadios.terryo.org>1.0 PURPOSE

This report covers all of the work done on the Signal Corps Development Contract W36-039-sc-44552 which resulted in the development of the Radio Receivers R-389( )/URR and R-390( )/URR as specified in SCL-1134-B. The Signal Corps has plans for the development of a series of radio receivers which would provide reception over the frequency range of 15 kilocycles to 3000 megacycles. The receivers covered by the specification SCL-1134-B are two of this series and cover the frequency ranges 15 kc to 1500 kc and 500 kc to 32 mc. The purpose of this project was to develop and build three models of each of these receivers along with their required accessories.

These receivers would fulfill many needs of the Armed Forces but in general there were two basic requirements. First, to provide the increased stability and calibration which is becoming almost a necessity in modern communication systems; and second, to combine into one general purpose receiver as many as possible of the facilities and special circuitry that are now being used by the various branches of the Army and which now require many different receivers to provide. Along with these receivers were developed accessories such as special power supplies and cabinets. There were also instruction books prepared and a complete set of manufacturing drawings. Throughout this program a great deal of effort was made to use the very best and latest types of components and materials. Also very close contact was maintained with the Signal Corps Engineering Laboratories to fit these receivers into their very latest plans for communication systems.

The purpose and responsibilities of this development project were doubly emphasized when, after the first two engineering models were submitted, a contract for production quantities of both R-389 and R-390 receivers was received by Collins Radio Company. In addition, a second company, Motorola, was set up as a directed subcontractor for a large quantity of R-390 receivers. These production contracts resulted in serious responsibilities being placed on the development work, since both labor and factory space commitments were made by both companies. During the latter part of the development program, a great deal of time and effort was diverted from development to production, thus aiding production but delaying the final phase of the development program.

Therefore, during the latter phases of this contract, the objective was not only to develop these equipments as specified, but also to aid and ensure the delivery of production quantities.

2.0 ABSTRACT

This section contains a brief resume of the report to follow emphasizing the difficulties encountered and the progress made.

The report covers the work done in fulfillment of the development contract for the R-389 and R-390 receivers. Although it is divided into

Courtesy of <http://BlackRadios.terryo.org>

seven sections, the main body information is contained in the section on Factual Data. The Factual Data section is divided into three main tasks covering the Planning, Models, and Final Report.

The Planning Section covers the work done before any actual model building could be started. This was actually a very important stage and took considerable time, mostly spent on the RF sections. The main problems here were spurious responses due to the complicated mixing scheme required for stability. The final performance of the equipment did not meet the desired 80 db level, but was still better than previous equipment and satisfactory to the Signal Corps.

The Model Building Section contains a detailed description of all the development work done on this contract and is divided into and covers various topics much the same as the equipment is divided into sub-units. These topics are as follows:

#### 1. Mechanical Design.

This covers the basic structural layout and mechanical drive systems. The drive systems for both receivers were the most difficult of the mechanical design problems. A great deal of time was spent in working out gear trains and mechanical drives which were not only easy to maintain but also as rugged as possible. The systems finally used are much more complicated than similar receiving equipment but were the best means possible to accomplish the tuning required.

#### 2. Power Circuits

This covers the design factors and performance of all three different power units and their associated circuits. The electronic regulator design was the biggest problem due to the requirement for a plus or minus 15% input voltage, but was finally satisfactorily overcome. The external 110 volt DC supply also required a lot of time since so many different systems were tried. The rotary machine finally shipped on the contract seemed to be the best compromise for this unit.

#### 3. Audio Circuits

This covers the design of the audio circuits and their performance. The main problems were the filter and metering circuits which were overcome without too much difficulty.

#### 4. IF Circuits

This covers the design of the IF circuits giving detailed design of various transformers. This section is rather long since the IF performance was considered as one of the major features of this equipment. The main problem in the IF was to get the desired bandwidths and to hold good performance under temperature and humidity. The IF bandwidths turned out quite satisfactorily, but the temperature and humidity problem was not completely resolved.

Courtesy of <http://BlackRadios.terryo.org>

### 5. RF Sections

This covers the development of the R-389, R-390 RF sections including the R-390 crystal unit. The RF units were undoubtedly the most difficult to design of the entire equipment since they include both mechanical and electrical problems. The electrical difficulties included sensitivity, spurious responses and mixer design. All of these problems have been worked out satisfactorily.

### 6. Variable Oscillator Designs

This covers the BFO and VFO design for both the R-389 and R-390. The main problem in all of these oscillators is stability which came out rather good although further improvement is being considered.

### 7. Crystal Calibrator

This covers the design of the 100 kc crystal calibrator unit in which the main problem was the multi-vibrator performance. This is now considered satisfactory except for the possibility of circuit aging which will be investigated during production.

### 8. Special Circuits

This covers the work done on special circuits such as the AGC system, noise limiter and others. No major problems were involved in these special circuits.

To complete this work it has taken approximately 30,000 engineering man hours implemented with laboratory technicians and drafting help. This work has been spread over a three-year period with the delivery schedule as follows:

Project Started	June, 1949
R-390 No. 1	January, 1951
R-389 No. 1	March, 1951
R-390 No. 2	September, 1951
R-389 No. 2	February, 1952
R-390 No. 3	February, 1952
R-389 No. 3	May, 1952
Miscellaneous Accessories	February, 1953
Final Report	August, 1953

Courtesy of <http://BlackRadios.terryo.org>

The accessories and later items required by this contract, which include drawings and final report, have been delayed considerably, due to the efforts being made to meet production schedules for some of these same equipments.

In general, this report has stressed only the new and important points of this work and has left many of the lesser details to the monthly reports and instruction books. For a more complete record of this program, the other publications should be consulted.

3.0 PUBLICATIONS

The following is a list of publications which are directly concerned with this project and may be used to supplement this report:

1. Engineering Proposal for R-219 Receiver - Collins Radio Co.
2. Monthly Reports - Contract DA36-039-sc-41552 - Collins Radio Co.
3. Instruction Book, R-389 - Collins Radio Co.
4. Instruction Book, R-390 - Collins Radio Co.
5. Manufacturing Drawings and Specifications - Collins Radio Co.
6. R-389 - R-390 Specification SCL-1134-B (Development)
7. R-389 - R-390 Specification MLL-R-10474 (Production)
8. R-389 Type Test Procedure - Collins Radio Co.
9. R-390 Type Test Procedure - Collins Radio Co.
10. R-389 Production Test Procedure - Collins Radio Co.
11. R-390 Production Test Procedure - Collins Radio Co.
12. 515-3 Instruction Book - Collins Radio Co.

4.0 FACTUAL DATA

This section contains a discussion of the work accomplished during this contract. This work can be broken up into separate tasks as follows:

Task A - Planning

Task B - Model Building and Testing

Task C - Drawings and Report

Most of the time was spent on Task B which involved the building and testing of six complete models with all their accessories.



Courtesy of <http://BlackRadios.terryo.org>4.1 Task A - Planning

The work of planning a project of this size is quite extensive and began with the first proposal submitted for bidding purposes. At that time a detailed analysis of the specification was not practical and only generalized planning was done. However, it was apparent at this time, that the basic requirement for these receivers, was a high degree of stability and calibration. This stability and calibration was obtainable only by special superheterodyne systems and the first major problem to be solved was the determination of the frequency schemes to be used.

In the engineering proposal for this development contract submitted in March, 1949, it was stated that the frequency scheme to be used in heterodyning the received signals down (or up) to a fixed IF frequency would be similar in basic principal to the Collins, commercial, communications, receiver, the 51J. This basic principal is to build a tunable, low frequency receiver covering a one megacycle range with extreme accuracy and stability. This low frequency receiver is then used as a tunable IF strip for the higher frequencies by using fixed crystals to heterodyne one megacycle ranges of the higher frequencies down to the tunable IF range. A typical heterodyne system, as described above is shown in Figure 1.

The above scheme is not usable throughout the entire frequency range covered by these receivers so special frequency schemes were needed below about 8 megacycles. The best way to cover these lower frequencies was determined to be by use of "triple conversion." A typical frequency scheme of this type is also shown in Figure 1.

Before any actual numbers for signal ranges and injection frequencies could be decided upon, several points had to be carefully considered. The most important of these were (1) spurious signals, (2) circuit complications, and (3) mechanical problems. The specification called for all spurious to be down at least 80 db and this was the design goal. There was no actual limits on circuit complication although it was known that reliability and ease of maintenance were important considerations. The mechanical problems for switching and tuning such a system could be very great, so mechanical simplification was given considerable thought during this planning phase.

The spurious response were first considered to be of two general types, but later a third type caused serious trouble and some changes had to be made. The first type occurs when the IF is higher than the signal and is such that harmonics of the signal feed directly into the IF. This can be expressed simply that  $n F_s = IF$  where  $F_s$  is the signal frequency and  $n$  is an integer and is considered as the order of the spurious. One of these occurring in Figure 4 would be at 3.0 mc in the 3-4 band when the 5th harmonic of 3 mc would fall in the high IF (15 mc). This would be a 5th order spurious.

Courtesy of <http://BlackRadios.terryo.org>

The second type of spurious occurs when the signal or its harmonics beat with the injection or its harmonic to give the IF frequency. This can be expressed by  $n F_s \pm m F_x = \pm IF$  when  $F_x$  is the injection frequency and  $m$  is an integer. The order of this type of spurious is  $(n + m)$ . This type occurs in Figure 4 in the second mixer at 15 mc when  $(3 \times 15) - (4 \times 12) = -3.0$ . This would be a 7th order  $(3 + 4)$  spurious and would occur on every band.

During the early stages every attempt was made to devise frequency schemes such that no spurious below the 7th order would present. However, when mechanical problems and space limitations were considered, this limit was dropped to 5th order.

At this time it was also found that there was no standard method of spurious response measurement. The following method was used throughout this program:

1. Set a standard audio output for a 5 microvolt input on signal frequency.
2. Tune generator to spurious frequency and increase to same audio output.
3. Spurious response ratio is the ratio between spurious input and 5 microvolts.

When it was found necessary to allow 5th order spurious in the systems, it was realized that the 80 db figure required in the specification could not be met. However, it looked like a limit of 60 db would be possible and seemed to be acceptable to the Signal Corps as the best possible compromise.

The third type of spurious response mentioned previously should actually be classified as "internal signals", since they require no signal input. These are caused by the beating and mixing of the various oscillators within the receivers and are sometimes called "tweets," "whistles," or "birdies." There was no exact specification on internal signals and likewise no standard method of measurement. The method set up for measurement was to compare the output of the internal signal to an equivalent external signal and express its strength in microvolts. The original design limit set on internal signals was one microvolt maximum, but considerable trouble was encountered in trying to meet this limit. The latest models had approximately the following performance on internal signals:

Total number	25
Less than 1 microvolt	20
1 to 2 microvolts	4
2 to 3 microvolts	1

Courtesy of <http://BlackRadios.terryo.org>

The strongest of these signals occur when the receivers are tuned to an internal oscillator frequency or some oscillator harmonic. They also may occur when two oscillators or their harmonics differ by one of the IF frequencies. Considerable planning and testing of various frequency schemes was done before any of the actual models could be started.

Before much frequency scheme planning could be done, it was necessary to determine the spurious response characteristics of mixers. This required considerable time, but did show about what could be expected for various types of mixer tubes and various operating levels. The best compromise found was to use a triode mixer which had a remote cut-off characteristic. This gave a low noise figure and fairly good spurious performance. The mixer tube chosen was a 6C4 which gave 60 db rejection to a fifth order spurious. This was considered usable and so a fifth order was set as the lowest order cross-over to be allowed.

Several frequency schemes for the R-389 were actually built in bread-board style before they could be fully evaluated. A more detailed description of these various systems is given under the R-389 RF section (4.2.5). The final system is shown in Figure 2.

The R-390 frequency scheme was broken up into two ranges. The high range above 8 mc would be a conventional double conversion system similar to the commercial 5LJ receiver. Below 8 mc, triple conversion was to be used. A great deal of calculating was required for the low range to pick crystals and high IF ranges that were usable. The main requirements were to avoid low order crossovers and to have the high IF ranges for all seven bands be within a 2:1 tuning range. The final R-390 frequency system is listed in Table I and block diagram is shown in Figure 3.

At the same time that the detailed planning of the RF portion was being done, a thorough study of the specification was made and tentative plans were laid out for all parts of both receivers. One of the first problems encountered was the physical and mechanical makeup required of these receivers. The specification called for an immersion-proof case design which presented many problems but mainly one of temperature rise and heat dissipation. Since no air could be circulated in or out of a sealed case, the first thoughts were toward meeting this requirement by radiation of the case alone. Tests were made using a temporary case approximately the correct size with an estimated power requirement of the equipment. These early tests showed that high temperature operation was a very serious problem and would require special heat-exchange units to keep the receivers within practical temperature limits.

At this point the Signal Corps decided that the requirement of a water-tight sealed case should be dropped rather than add any large expensive cooling system. This also fit in with their ideas for a separate smaller receiver for mobile field use and limiting the use of the R-389 and R-390 units to fixed station use. This mobile receiver was later developed to be used as part of the GRC-19 equipment and was typed the R-392/URR.



TABLE I  
 R-390 Frequency Scheme

Band	Freq. Range	Coil Range	1st Mixer Crystal	High I. F.	2nd Mixer Xtal Inj.
0	.5 - 1	.5 - 1	9	9.5 - 10	12 12
1	1 - 2	1 - 2	8	9.0 - 10	12 12
2	2 - 3	2 - 4	10	12.0 - 13	15 15
3	3 - 4	2 - 4	12.6	15.6 - 16.6	6.2 18.6
4	4 - 5	4 - 8	7	11.0 - 12	1- 14
5	5 - 6	4 - 8	8	13.0 - 14	8 16
6	6 - 7	4 - 8	9	15.0 - 16	9 18
7	7 - 8	4 - 8	10	17.0 - 18	10 20
8	8 - 9	8 - 16			11 11
9	9 - 10	8 - 16			12 12
10	10 - 11	8 - 16			13 13
11	11 - 12	8 - 16			14 14
12	12 - 13	8 - 16			15 15
13	13 - 14	8 - 16			8 16
14	14 - 15	8 - 16			8.5 17
15	15 - 16	8 - 16			9 18
16	16 - 17	16 - 32			9.5 19
17	17 - 18	16 - 32			10 20
18	18 - 19	16 - 32			10.5 21
19	19 - 20	16 - 32			11 22
20	20 - 21	16 - 32			11.5 23
21	21 - 22	16 - 32			12 24
22	22 - 23	16 - 32			12.5 25
23	23 - 24	16 - 32			13 26
24	24 - 25	16 - 32			9 27
25	25 - 26	16 - 32			14 28
26	26 - 27	16 - 32			9.66 29
27	27 - 28	16 - 32			10 30
28	28 - 29	16 - 32			10.33 31
29	29 - 30	16 - 32			10.66 32
30	30 - 31	16 - 32			11 33
31	31 - 32	16 - 32			11.33 34

With the temperature problem simplified, the planning of the entire mechanical layout could be started. Most of the basic circuits for the entire receiver had been layed out and the approximate space requirements were figured. Since unitized construction was to be used, the first problem was to combine the basic circuits into units, keeping in mind the desirability of interchangeable units between the R-389 and R-390 models. Three common units were arrived at and were the power, audio, and IF units.

Courtesy of <http://BlackRadios.terryo.org>

The variable frequency oscillators were to be the same size as the standard Collins VFO except for the addition of the temperature control ovens. This left the two RF units plus a few miscellaneous items to be fitted into the allotted space.

At this point, the planning phase of the project was considered at an end, and the building of models could be started.

#### 4.2 Task B - Model Building and Testing

The contract called for one experimental model of each receiver to be delivered followed by two engineering models of each. The actual program started with a paper mock-up model used to locate sub-assemblies and allot space for each. This paper model was followed by "bread-board" models which were the first attempt to package the bread-board circuits into their proper sub-units. These models were never really functioning models and were never delivered to the Signal Corps. The next models built were the so-called engineering models and were actually delivered to the Signal Corps for their comments. Since there were many known deficiencies in these engineering models, the design of the next models were actually started before the engineering models were delivered. The Signal Corps engineers were working very close with the contractor at this time so many of their opinions and changes were incorporated into units before actual submission. Rather than build the second and third models together it was decided to build only the second and hold the third models for any changes which were required by number two. This undoubtedly delayed the program but resulted in the third models being much more complete and more acceptable to the Signal Corps.

##### 4.2.1 Mechanical Design

The mechanical design work on these receivers was not started until the electrical planning was far enough along to give good information as to components and their location. One of the first things investigated was the case design which was specified to be water-tight. This meant the problem of cooling had to be considered since excessive temperature rise could be very serious. A power dissipation of 100 to 150 watts was estimated and temperature rise measurements were made using a temporary case of the approximate construction. These tests showed that the temperature rise was way too high unless a very effective cooling system was also used. Rather than complicate the equipment with these extra parts, the Signal Corps dropped the requirement for a water-tight case in exchange for both a collapsible table cabinet and a rugged vehicular case. Both of these cases could be ventilated so the cooling problem was simplified considerably.

The next step was to build a paper model of the equipment, and work out the space and positions for the various sub-units. This step resulted in the use of an "H" type frame on which units mount from both top and bottom. This basic design can be seen in Figures 21 and 22. Also mounting on this frame were the front and back panels, and the top and bottom dust covers.

Another requirement which influenced the design of this frame was the possibility of adding automatic tuning to the R-390 at some future date. Space for the automatic tuning heads and motor was left in the equipment and provision for a separate casting for mounting these parts was made. The addition of the motor and "autotune" heads was done later for the FRR-33 equipment and this model of the receiver was called the R-391.

The actual construction of the frames is rather unique in that it is made up of six formed pieces, spotwelded together to give its final shape, and giving double thickness at all points. The frames for the R-389 and R-390 are identical except for differences in unit mounting holes so that the same forming tools can be used.

Captive screws on the sub-units were used to hold the units to the frame. Flush mounting nuts which pressed into the frame were used for mating with these captive screws. Number ten mounting screws were used and gave very little trouble in shock and vibration tests. These mounting screws can be clearly seen in several of the unit photographs such as Figure 27.

The units are connected together by a main cable which is a part of the front and rear panels. This allows the cable and panels to be built separately and then attached to the frame.

It should also be noted in Figures 4 and 5 that the handles on the front allow the equipment to be rolled over or stand on its face without damage to controls. This is also carried out on the rear panel, Figures 5 and 16, where bumpers are placed on either side to protect the rear terminals and allow the equipment to be set down on the back without damage. These back bumpers also have holes which engage pins in the vehicular applications in order to hold the back end better. The rear view of these receivers in Figures 5 and 16 also show the location of the tools and tube pin straighteners which were included. The plate showing in the lower right rear of the R-390 covers the hole which is used for a remote cable when converted for automatic tuning. There were no provisions made for remote tuning of the R-389, since no requirements for this type of operation could be foreseen.

Mounting on the top and underneath the main frame are seven main sub-units. These are (1) power units, (2) audio unit, (3) I-F unit, (4) RF unit, (5) crystal oscillator, (6) calibrator and (7) variable frequency oscillator. These units ended up in their various positions due to a fairly logical arrangement. The VFO which is the main frequency determining unit, required direct coupling to the main tuning knob and so was placed directly behind the tuning knob. The obvious place for this tuning knob was in the center of the panel where it could be easily reached for manual tuning. Since there were mechanical linkages necessary to the RF tuning, the RF unit was placed just above the VFO and extend to the right side. This allowed the band change knob to connect to the RF unit and still be on the lower right of the panel for ease in operation. This also allowed the frequency counter to be part of the RF unit and still be



Courtesy of <http://BlackRadios.terryo.org>

in the center of the panel where it should be. The crystal oscillator unit required band switching and so was placed directly behind the RF unit and coupled into the band change drive. The shaft was also brought out the rear for synchronizing the oscillator and for power to band switch external units. This feature was later used for driving the URA-13 exciter unit and the three mounting holes for this attachment can be seen around this shaft hole.

The only other mechanical linkage necessary to be brought out through the front panel was the IF bandwidth switch and the BFO pitch control. Since these were both on the IF unit, this was placed on top next to the RF. The other units which had no mechanical drives were placed underneath the frame as shown. One very desirable feature which came out of this arrangement was that all normal alignment, both RF and IF, can be made from the top while the crystal oscillator trimming condensers are available from the back.

The power unit for AC operation is shown in Figures 23 and 24. The three captive mounting screws can be seen along with the four tapped holes in the power transformer itself, which fastens the transformer directly to the side of the main frame giving extra support to this heavy unit. The guard bracket around the plug should also be noted. The DC power unit is shown in Figure 25. This unit mounts by two screws into the front side and two captive screws accessible through the holes seen in the top. The same frame mounting holes are used for both AC and DC units. The dynamotor has rubber isolation washers under its cradle to reduce noise and the boxed-in portion contains filtering components for the electrical leads.

The audio unit is shown in Figures 26 and 27. The mechanical construction of this unit is straight-forward except for the shelf in the chassis to hold the large regulator tubes. The sockets on this shelf are of a very flat design to allow for the extra tube height. The holes around these big tubes are for ventilation.

The IF unit is shown in Figures 28 and 29. The sealed unit under the chassis is the BFO and is shown opened in Figure 30. This unit is turned through the "bellows" type coupler since the shaft is threaded and moves in and out of the oscillator. The construction of some of the IF transformers are shown in Figures 31 and 32.

The R-F units were started as soon as their frequency schemes were determined. These units were by far the most complicated part of the equipment both electrically and mechanically. The basic mechanical problem was to tune and switch the required number of circuits in the allotted space. Tuning of the RF circuits by means of moving iron cores had been decided upon previously, since this was the easiest method for handling so many circuits and it also eliminated the design of a special tuning condenser. To cover the necessary tuning range in the R-389 coils, approximately 1-1/4 inches of motion was required. This ruled out cams for lifting the tuning rack since there was not enough room to swing cams this size. To do the job of moving the racks, reversible lead screws similar

Courtesy of <http://BlackRadios.terryo.org>

to those used if level wind fishing reels were used. These can be seen in Figure 12. Figure 13 shows the worm gears used to drive these screws such that different worm and gear ratios allow the various racks to be moved at different speeds while all are being driven from the same tuning knob. Figure 71 is an exploded view of the R-389 mechanical system showing detailed operation.

In the center of the RF unit is a motor-driven band switch which automatically selects the proper coil range as the receiver is tuned. This motor is operated by a commutator whose various segments are arranged to correspond to the desired bands. This entire tuning and bandswitching system is driven by the gear train shown in Figure 14 which also drives the frequency counter or dial. In order to speed up the tuning of this receiver, which was rather slow due to the large number of moving parts, a tuning motor was used and can be seen in Figure 13. This motor tuning allows the entire range of the receiver (200 turns) to be covered in less than 40 seconds. It can be seen in Figures 12 and 14 that ball bearings are used in many places to reduce the load on the tuning shaft. Considerable testing was done on the reversible lead screws and followers to find the best materials and lubricants to reduce drag and wear. The final lead screws are chrome plate brass with hardened steel followers. The construction of the R-389 RF coils is shown in Figure 15. The coil itself is covered by a large powdered iron sleeve seen behind the trimmer coil. A tuning slug is included in this photograph to show how silver bands are placed around the slug to lower the circuit "Q" as it goes into the coil. The slug wire shown is a phosphor bronze spring which is necessary to reduce shock and prevent breakage.

The R-390 RF unit is shown in Figures 35, 36 and 36A. This unit also uses permeability tuning, but only requires 0.800 inches travel. This allows the slug racks to be driven by means of cams. Both the cams and cam followers can be seen in the rear view of Figure 36. The design of these cams is such that 300 deg rotation is used for accurately lifting and positioning the racks while the other 60 deg is used as a quick return. The positioning portion gives a linear rise while the return portion is designed for minimum torque requirements. These cams all operate in a precise sequence and the marks for synchronizing them can be seen on the rear plate. Adjustment of each pair of cams is possible since they are driven by a gear which has a split hub and is clamped on its shaft.

The exploded view of the R-390 mechanical system is shown in Figure 72 which shows the entire detailed operation. A rather special design is the Geneva and overtravel coupler used to drive the RF band switch. This mechanism allows the 30 position megacycle knob to switch the six RF coil ranges in and out at the proper time. The R-390 also uses a dial corrector which allows the drive to the frequency counter to be released through a clutch while the receiver is set to correct frequency. The frequency counter or dial is a part of the RF gear train and required special development by the manufacturer of a geneva type transfer in order to meet the speed requirements of the automatic tuning system. In order to reduce error and

Courtesy of <http://BlackRadios.terryo.org>

backlash, most of the gears in this unit used are of the split-loaded type. There is one differential gear assembly used and in the case of the first IF tuning, a differential motion is achieved by actually moving the coil cans slightly with one cam while the slugs are driven by another.

For ease in assembly of the R390 RF, the gear train can be built separately from the RF chassis as shown in Figures 37 and 38. The coil assemblies can be plugged in and typical assemblies are shown in Figures 39 and 40. The variable pitch of the winding necessary for straight line frequency can be seen in these pictures.

During the vibration tests on the later models of the R-390, several things showed up which required changes in the future units. For one thing, the loaded gears caused considerable wear due to their "chewing" action when driven by brass pinions. The pinions were changed to steel to relieve this problem. It was during these vibration tests that the need for the spring wires on tuning cores instead of a solid wire was found. There was also some indication of the rack followers "pounding" the brass cams causing dents, but this was not considered serious enough to warrant steel cams since the cutting of the softer brass cams is less of a manufacturing problem.

When this RF unit is placed in the main frame, its gear train meshes with the two knob gears which are on the lower casting. The tolerances involved here are rather large and a procedure for "shimming" the casting when it is mounted into place is required. The RF unit itself is located by its front gear plate resting on the bottom of the main frame and being held against the side of the frame by two side screws. A better way to tie these two gears together would have been to use a common gear plate but the requirements of interchangeability with the automatic tuning system made this impossible without considerable redesign.

The normal use for both equipments is in a fixed station where they would be mounted on a relay rack in a normal fashion. However, special cases were designed for use in table mounting and vehicular use. The table cabinet is shown in Figure 49 and can be taken apart for shipment as shown in Figure 50. The vehicular case is very similar in design except for more rugged design which includes permanent welding instead of being collapsible.

This covers the general mechanical design of the equipment and the various circuits and subassemblies will be taken up separately.

#### 4.2.2 Power Units

There were two power supplies developed for these receivers under this contract. One for 115/230 volt AC operation and one for 28 volt DC operation. These two units are completely interchangeable except that power cords and line fuses must also be changed. They both fit into the same space in the equipment and are mounted in the same holes.



### 2.2.1 AC Power Units

The AC power supply unit is shown in Figures 23 and 24. A complete power schematic is shown in Figure 51.

Early in the program it was decided that the most efficient way, in both space and weight, to supply plate power for the receiver's operation, would be to use electronic regulation throughout. This was dictated by several things. First the need for close voltage control on all oscillators in order to meet the stability requirements. Second, the need for close voltage control on amplifier stages since gain variations were to be held to a minimum. Third, the space and weight required would be less than if condensers and chokes were used to do same amount of filtering. Fourth, the transformer voltage would be lower than if the same voltage regulating were done with V-R tubes. Fifth, the actual power dissipation would be lower than with a comparable choke, condenser, and V-R tube system. One disadvantage of an electronic regulated system would be the extra tubes and circuits needed, however, this was not considered to be a serious objection.

The decision to use 180 volts for the plate supply voltage was influenced by several factors. First, it was desirable to keep voltage as low as possible because of heat dissipation, component size and rating, insulation problems, and shock hazard. The factors requiring high voltage were power output requirements, oscillator performance, and the front-end requirements on blocking and cross-modulation. The value of 180 volts was selected as a compromise between these various factors.

Early in the program a B+ current requirement of 125 ma was estimated and the first power supply circuits were built accordingly. As the equipment was developed more and more current was required until the last models ended up using about 200 ma. The supply shown will deliver 200 ma at 180 volts with excellent regulation and low ripple content as the following data indicates:

Input voltage variation of $\pm 15\%$	B+ variation $\pm 1$ volt maximum
Load current variation 100 to 200 ma	B+ variation $\pm 2$ volt maximum
Ripple voltage normal	0.01 volts
Ripple voltage worst condition	0.1 volts

In order to get a transformer to handle this amount of power in a small size, Class B insulation was used in transformer. This allows the transformer to run at 125 deg C at its hottest point.

Some of the early, lower current models used a 5U4G for a rectifier tube, however, the latest models use two 25Z5W tubes. In order to reduce the peak current and to balance the parallel sections, a 47 ohm resistor



Courtesy of <http://BlackRadios.terryo.org>

is placed in series with each cathode. This supply feeds approximately 250 volts into the electronic regulator circuit as shown in Figure 51. Two 6082 tubes in parallel serve as series regulating elements and are controlled by a 6BH6 DC amplifier coupled to their grids. This 6BH6 is fed from the regulated B+ through two 5651 gas tubes which present a constant voltage drop. Thus any variation from the 180 volt value is amplified by the 6BH6 which changes the 6082 bias so as to bring the voltage back to 180 volts. AC filtering is accomplished first by the large input condenser on the regulator plates and also by feeding out of phase ripple back through the 6BH6 amplifier. This is done both through its grid circuit and plate circuit with a "ham balancing" potentiometer in the plate coupling circuit. This circuit worked very well both for AC filtering and also serving as a low impedance for AC in the B+ circuits. However, an extra 10 mf condenser was later found necessary on the B+ line to reduce audio coupling through the power supply.

The 6082 tubes were developed by RCA on a Signal Corps development contract and were very desirable because of their low plate impedance, small size, and high current capacity. The 47 ohm resistors in each cathode lead serve to balance the parallel sections. Some of the early models were built using only one 6082 but were found to be inadequate for the amount of power dissipation. Two tubes just handle the power when the voltage is maximum. The heat developed by these tubes is quite high and every possible means of cooling has been done. Even so all components in this area were selected for maximum temperature operation. These tubes mount on the audio unit upside down on the lower side of the equipment which also made the heat problem worse. Some trouble was experienced under vibration with the 6082 tubes due to foreign pieces of material inside causing momentary shorts. The manufacturer is investigating this and hopes to find a remedy.

Also in the power unit is a 6 volt dc supply for the antenna, break-in, and squelch relays. This supply is a bridge type circuit using a copper-sulfide rectifier. The main problem here was effect of heat and moisture on the rectifier itself. These problems were solved by designing the relays for a minimum current drain and by adding extra finish coats of varnish to the rectifiers. Very little trouble has been experienced with this circuit.

The filament regulation circuit for the oscillator filaments should also be covered here although this ballast tube is mounted on the IF unit. Considerable work was done with Amperite Corp. in designing this special ballast tube which feeds a constant 300 mils to the two 6 volt 300 mil oscillator tubes used in the VFO and BFO. These three tubes are connected in series across the 26 volt filament supply. The ballast tube (3TF7) operates on a current of 290 to 330 mils and holds this current within  $\pm 10$  mils for input voltage variations of  $\pm 15\%$ . This reduced the 15% variation to approximately 3%. There is some question if a filament regulator is necessary in these receivers since the oscillators are very good even without regulation. However, since the stability was a big factor in this design and since the factor of tube aging was not known, the regulator was included.

Courtesy of <http://BlackRadios.terryo.org>2.2.2 28 Volt D-C Power Unit

The 28-volt DC power supply is shown in Figure 25. The complete schematic of this unit is shown in Figure 52.

The design of the 28 volt DC power supply was a relatively simple matter except for the noise filtering problems. The requirement for this DC operation was the reason for using 28 volt filament strings throughout the units. The design of the dynamotor itself was no problem other than changing the current rating as the receiver load increased during the program and in keeping the overall size down. The final model of this dynamotor was supplied by the Electrolux Corp. of Connecticut.

The problem of dynamotor brush noise, especially when used with the low frequency receiver, was quite serious. Several different filter designs were tried before an adequate circuit was found, and even then it was felt that some improvement could be made by further work.

This present 28 volt DC supply does cause a slight drop in signal-to-noise ratio at certain frequencies in both receivers, about 2 db in the R-390 and 3 db in the R-389. There is also some noise radiation back through the filament and power circuits, but with adequate shielding between these leads the antenna, trouble can be eliminated.

This dc power unit is interchangeable with the AC unit and uses the same electronic regulator system for the plate voltage. A special power cord and special fuses are required for dc operation. The power plug on the back of the radios have four pins, two of which are used for ac and two for dc operation. The negative side of the DC is always connected directly to ground. When operating from a 28 volt source, the R-389 and R-390 draw about six amperes for normal operation. When the oscillator ovens are turned on an additional four amperes are used intermittently, depending upon the heat necessary. The life expectancy of this dynamotor is about 1000 hours.

4.2.2.3 115 Volt DC Operation

The equipment specifications also required a separate power unit for 115 volt D-C operation. An investigation into the possibility of using the R-389 and R-390 receivers on a 115 v dc source indicated the power unit would have to conform to the following requirements:

1. Input voltage: 115 v dc  $\pm 15\%$ . For this 15% change in input voltage, ac output voltage must not vary more than 15%.
2. Output power: 300 watts

Courtesy of <http://BlackRadios.terryo.org>

3. Wave shape: Sinusoidal, with no RF noise or harmonics at frequencies from 15 kc to 32 mc in excess of 100 microvolts (peak volts). Radiated noise must be below 10 microvolts per meter at a distance of 2 feet (15 kc to 32 mc).
4. Frequency stability: Output frequency may not exceed the limits of 50 to 60 cps over the voltage and temperature range, and from no load to full load.
5. Ambient temperature: -40 deg C to +65 deg C operating, -62 deg C to +65 deg C non-operating.
6. Humidity: Operation after storage in humidity up to 100%.
7. Altitude: Transportation at altitude of 35,000 feet, with operation up to 10,000 feet.
8. Unit to be fungus-proofed per MIL-T-10513.
9. Expected life should be 1000 hours or greater without parts replacement.

The first type of inverter investigated was a vibrator unit, and a commercial unit was purchased for test purposes. Although the power output was adequate, the voltage regulation was not too good. The vibrator harmonic noise at 15 kc to 500 kc was excessive, and tests indicated that it would be extremely difficult to filter this unit to prevent noise radiation at these frequencies. This is due to the basically non-sinusoidal wave shape obtained from the vibrator, which results in many harmonics of the vibrator frequency appearing in the output voltage. Vibrators would have to be replaced about every 1000 hours. These vibrators have a net price of about eight dollars.

The second type of inverter investigated was a thyatron supply. The thyatron system has the advantage of no moving parts, and can be made to operate over the required temperature range satisfactorily. Systems for regulating the output voltage and frequency could be devised which would bring them within specification limits. However, there are several disadvantages to a thyatron inverter. The unit becomes fairly complex in order to meet all of our requirements and the component parts are quite expensive and bulky. Thyatron tube life could not be guaranteed for longer than 1000 hours and these tubes have a net price of about \$25 each. Two tubes would be used per unit. RF noise measurements indicated that it would be fairly difficult to get adequate filtering of the output. A production quotation for 1000 of this type of unit was about \$450 each. A schematic diagram of the Collins experimental inverter is shown in Figure 53.

The third type of inverter investigated was a small commercial rotary inverter. The unit had an internal governor which regulated the output voltage to within 3% for a 15% input change. Output frequency is likewise



Courtesy of <http://BlackRadios.terryo.org>

regulated by the governor to  $\pm 3\%$ . RF noise and harmonics were checked using an R-389 receiver, and it was found that with an antenna connected to the receiver, the inverter had no effect on the noise level of the receiver. The receiver was tuned over its complete range between 15 kc and 1500 kc., checking for noise and harmonics, and operation was considered satisfactory. An R-390 receiver was also used and the noise checked satisfactory from 500 kc to 32 kc. With proper lubrication, temperature extremes should have no adverse effect upon the inverter. It had been moisture and fungus proofed per MIL-T-10513. A production quotation of about \$155 each for this type of unit in quantities of 1000 was obtained. The estimated life of this machine would be 5000 to 10,000 hours. Mechanical noise is somewhat of a problem in a rotary inverter although it could probably be mounted in a location far enough from the receiver to be unobjectionable.

Of the three types of units tested, it appears that the best compromise would be the rotary machine. It can be made to satisfactorily meet all of the requirements outlined for this equipment and is cheaper to build and maintain than the thyatron supply. The vibrator supply is not acceptable because of the high RF noise level it generates. Six of the rotary converters manufactured by Eicore Inc. of Chicago were shipped to the Signal Corp on this contract. An outline drawing of these units is shown in Figure 54.

#### 4.2.3 Audio Circuits

##### General Design

The AF unit was designed to provide the required output within the specified distortion limits with a minimum of power drain. Provision is made for switching in suitable audio filters to give either a peaked frequency response at 800 cps or a frequency response which cuts off sharply above 3500 cps.

##### First Audio Stage

One half of a 12AU7 was chosen as the first audio amplifier. Operation with an unbypassed cathode reduces distortion and allows a greater grid input voltage swing. This is important because this tube is operated directly from the detector circuit without an intervening gain control. It is so designed that the last IF tube will overload before this first audio stage begins to draw grid current. Since it was most convenient to use filters in the medium and sharp positions having impedances of 600 ohms, the first audio stage is transformer coupled to these filters. An audio response selector switch selects the proper filter and/or attenuator to keep the output constant (at 800 cps) irregardless of the switch position. The output of the filter in use is fed to two parallel 2500 ohm audio gain controls. One of these gain controls is shunted with a 1200 ohm resistor to present a combined load of 600 ohms to the audio filter.

Courtesy of <http://BlackRadios.terryo.org>Local Output

One half of a 12AT7 grid is fed from the local gain control. Its plate is coupled to the grid of the 6AK6 local output tube. Negative feedback is employed from the plate of the 6AK6 to the cathode of the 12AT7 to reduce the output impedance. This negative feedback reduces the voltage gain considerably and in order to bring it back up to a reasonable level a small amount of positive feedback is provided by making a fraction of the cathode resistors of the half 12AT7 and 6AK6 common to both tubes. The effect of the positive feedback is to cancel the negative current feedback developed across the cathode of the half 12AT7 and so raise its gain.

Line Output

The other half of the 12AT7 has its grid fed from the line gain control. Its plate is coupled to the grid of the 6AK6 line output tube. In order to keep the input voltage about the same for rated output on both line and local channels, the plate resistor for the line output half of the 12AT7 was reduced to 82K ohms. This requires a slight juggling of both positive and negative feedback resistors to obtain the same condition of output impedance as for the local output.

Originally, the line output tube was a 6AK6 triode connected, but Signal Corps requirements for a -10 db position of the Line Meter switch necessitated 10 db more available power which made it necessary to go to pentode connections for this tube. Connected between the line output transformer and the line is a 14 db pad. When 10 mw is delivered to the load, the tube is actually putting out 250 milliwatts. When the Line Meter switch is in the -10 db position, the line meter is connected directly across the line output transformer secondary. Under this condition, the amount of power delivered to the line is 10 db less than that indicated by the VU meter. When the Line Meter switch is in the 0 position, the VU meter reads the amount of power delivered to the line. Under this condition, the VU meter is connected to the output transformer through a 10 db pad. When the Line Meter switch is in the +10 position, the amount of power delivered to the line is 10 db more than that read by the meter. Under this condition a 20 db pad is inserted between the output transformer and the line meter. The electrical operation of this switch is illustrated in Figure 55.

Squelch

The squelch threshold has been adjusted so that the squelch relay operates at about 5 volts on the diode load. With the RF gain control set at maximum, this corresponds to a signal strength of about 1 uv. The squelch relay is operated by the other half of the 12AU7, its grid being connected through an audio filter to the diode detector.

Courtesy of <http://BlackRadios.terryo.org>

### Output Tube Decoupling Filter

When a strong signal is tuned off to the side of the receiver selectivity curve, any random noise pulse is likely to set the receiver into a type of audio oscillation which depends on the continued presence of the external carrier for its maintenance. Audio is fed back from the output tubes to the B+ line which modulates this carrier. This is detected and fed to the audio and in this manner the oscillation maintains itself. Placing an extra decoupling filter between the output tubes and B+ broke the feedback circuit and stopped the oscillation. However, temperature requirements of the receivers necessitated use of a paper filter capacitor in the decoupling filter and it was impossible to get one large enough in the available space to completely eliminate cross-talk between the line and local channel.

### Break-in Relay

A break-in relay is used to silence the audio unit when an associated transmitter is in operation, and the receiver is being operated under "break-in" conditions. This completely eliminates any signal leakage which gets past the antenna break-in relay. Connecting this relay to the 600 ohm output from the audio transformer of the first audio stage eliminates hum pick-up troubles which have been experienced when this relay is used in a high impedance grid circuit.

### Audio Output Impedance Tolerance

The output impedance at the line output is 600 ohm  $\pm 10\%$  at all times. This is well maintained largely due to the presence of the precision 600 ohm pads on the line output channel.

At the local output channel the output impedance varies over a somewhat wider range, due to variations in feedback resistors, tubes, etc. On this channel a figure of 700 ohms  $\pm 20\%$  is attainable.

### Hum Level

A hum level of at least 50 db below the audio output is attainable for any audio level above 1 mw. While this does not meet specifications it is at least as good as broadcast transmitter hum levels which means that under ordinary use, the hum level at the audio output will be less than 3 db above the hum level sent by the transmitter.

### Audio Output

The local output is at least 500 mw at less than 10% distortion at 400 cps.

Although originally the line output distortion was also within specs (3% at 10 mw) but the necessity of placing a -10 db position on the line meter switch results in a 10 db waste of power, which with the other 4 db waste required to make the VU meter reading correct, results in a distortion at line output which reaches a maximum of 5% under some conditions.

Courtesy of <http://BlackRadios.terryo.org>Overall Audio Response

The original spec, SCL 1134-B, called for a 2000 cps low pass audio filter and a 1000 cps band pass audio filter. Before much work could be done on these, the spec was changed and a 3500 cps low pass filter was substituted for the 2000 cps low pass filter and the center frequency of the band pass filter was changed from 1000 cps to 800 cps.

The 3500 cps filter called for in the new specification, MIL R 10474 (Sig. C) was to be equivalent to Federal #12 1008B. A filter was procured and loaned to two filter suppliers. Both companies submitted satisfactory samples. Later it became necessary to add another series regulator to the audio chassis, and in order to accommodate it, the size of the filters had to be reduced. The problem was presented to the suppliers and they both came up with a design which cut the size in half with only a slight drop in the response characteristic. The final response curves are shown in Figure 56.

Because of space limitations, the 800 cps band pass filter does not quite meet the frequency response curve specified but was approved by the Signal Corps. The case of this filter was also redesigned to be identical with that of the 3500 cps filter in order to conserve space on the audio chassis.

Photographs of the final audio unit are shown in Figures 26 and 27.

4.2.4 I-F Circuits

The design of the intermediate frequency amplifier for the R-389 and R-390 Radio Receivers was based on specifications included in the original Signal Corps contract. These specifications included a complete description of each selectivity position (six in all) by means of bandwidth at several attenuation points. It also included several other items such as envelope phase delay, auxiliary circuits, and service conditions.

4.2.4.1 Specifications and Limits

The original specification called for six selectivity positions, named for the bandwidth at 6 db attenuation points. These were 0.1, 1, 2, 4, 8, and 20 kc positions. The 20 kc position was later modified to 16 kc at 3 db, and the 8 kc to be 8 kc at 3 db instead of 6 db. Bandwidths were given at 3, 6, 20, 40, 60, 80 db attenuation points for each selectivity position.

The following table lists the various positions along with the nominal bandwidth and shape factor for each. Shape factor is defined as the ratio of 60 db BW to 6 db BW.



Courtesy of <http://BlackRadios.terryo.org>

TABLE II

<u>BW Position</u>	<u>BW - 6 db</u>	<u>Shape Factor</u>
0.1 kc	0.1 kc	48
1.0	1.0	6.8
2.0	2.0	4.25
4.0	4.0	2.55
8.0	11.5	1.91
16.0	17.0	1.82

The other important electrical specification was envelope phase delay. This specified that the phase shift of a 150 cps modulating signal should not vary more than 4.63 microseconds ( $1/4$  deg) over the top band-pass (3 db pts.). This variation in phase shift of the modulating signal occurs because of non-linearity in the phase-shift vs frequency curve for any one or group of tuned transformers. Specification originally called for this requirement in the 2 and 4 kc BW positions. This was later modified to include only the 2 kc position. It was shown impossible to meet the requirements in the 4 kc position.

#### 4.2.4.2 Theoretical Considerations

The number of transformers needed, along with physical constants for each, are determined by the specifications for BW, shape factor, and envelope delay. According to universal curves for shape factor vs number of tuned circuits and coupling, it would require about 30 critically coupled IF transformers to yield a shape factor of 1.9 shown in Table II.

On the other hand it requires only four transformers with a coupling factor of three times critical to produce the same shape factor. This has the disadvantage of requiring at least one transformer to flatten out the humps in the selectivity curve caused by over-coupling. After considering various combinations, it was decided that the most economical design would be five transformers. If they were all critically coupled, it would yield a shape factor of 2.6 which is the requirement in the 4 kc position. For the maximum BW position, four of these transformers could be overcoupled at about 2.5 times critical and the remaining one used to fill in the double humps. This would yield a shape factor of about 1.8 with a reasonable hope that the top of the overall selectivity curve could be made flat with careful design.

It was discovered that the maximum linearity in the phase shift curve of a double-tuned transformer occurs at about 0.6 times critical coupling<sup>1</sup>.

<sup>1</sup>Gardiner and Maynard, I-F System Design Proc. IRE, VOL 32, P. 674, Nov. 1944

## Courtesy of <http://BlackRadios.terryo.org>

Four transformers at 0.6 times critical and one transformer at critical coupling gave the best envelope delay characteristic. This also yields a reasonable design for the 2 kc position, giving a shape factor of about 3.6. It should be noted that the best envelope delay characteristic would occur with the minimum number of tuned circuits. Therefore, this design is a compromise between selectivity and delay.

The 0.1 and 1 kc positions were logically suited only to a crystal filter. Even a 1 kc position using 5 transformers, undercoupled, would require Qs on the order of 200. Design of the crystal filter is included later.

The tuning capacitor was arbitrarily set at 1000 uuf. This is considerably higher than the usual design. However, since five or more transformers must be used for required selectivity, gain was not a problem and low impedance tuned circuits could be used. This is desirable for maximum stability.

The center frequency is quite important in the design of IF transformers. The frequency of 455 kc was chosen for several reasons. One is that it is considered standard in the industry for the final fixed IF frequency. Another reason is based on bandwidth requirements. A lower frequency would make narrow bandwidths possible with reasonable Q values, but would make the wide position difficult. A higher frequency would work the other way. A reasonable compromise is 455 kc for this particular specification. Of course, IF image rejection and spurious response entered into the selection also.

### 4.2.4.3 Overall Design

It has been established by theoretical considerations that the optimum number of transformers is five for the requirements shown in Table II. How to arrange these transformers in a practical circuit and calculate their design constants was the next problem.

#### Non-crystal Positions

The four non-crystal BW positions will be considered first. The design was based on Gardiner and Maynard's universal design curves for tuned coupled circuits<sup>1</sup>. The 4 kc position was obtained with five transformers, critically coupled with Q factors of about 125. It is assumed that all transformers are isolated by tubes.

The 2 kc position was more complicated because of phase delay considerations. Using the fact that maximum linearity in phase shift occurs at 0.6 times critical coupling, a design could be made. Five transformers at 0.6 times critical did not satisfy the requirements. It was necessary to add one with a compensating phase delay characteristic. It was found that one transformer at critical coupling just compensated for four

<sup>1</sup>Gardiner and Maynard, I-F System Design Proc. IRE, VOL 32, P. 674, Nov. 1944

Courtesy of <http://BlackRadios.terryo.org>

transformers at 0.6 of critical. The design requires close tolerances to meet the requirements. The 2 kc BW specification was also satisfied by this combination using all Q factors of 125.

It should be mentioned that the amount of envelope phase delay is determined by the slope of the phase shift curve of the five IF transformers. The phase shift must be calculated to at least four decimal places in order to determine the change in slope that would cause the 4.63 microsecond delay variation over the top bandpass of the five IF transformers. This sort of calculation is impractical by conventional means.

McCoy<sup>2</sup>, in his work on envelope phase delay, develops as a side-line an easy method of computation for attenuation as well as phase shift curves. This method is based on the exact equivalence, as far as selectivity and phase shift are concerned, of a series of symmetrically stagger-tuned single-tuned circuits to a series of double-tuned transformers having the same number of tuned circuits. This method is shown mathematically correct for any value of coupling in the transformers.

The big advantage of this method of calculation is in being able to find quickly and accurately any desired selectivity curve or phase shift curve by simple addition and subtraction. By McCoy's method, it was possible to calculate the performance of the proposed IF design beforehand. Actually, equipment was not available to measure envelope delay until the design was finished and transformers constructed. However, actual measurements were very close to predicted performance.

In the 8 and 16 kc BW positions, it was necessary to over-couple four of the IF transformers as well as lower Q to obtain the desired shape factor and BW. The first transformer is used to counteract the rise in voltage on either side of the resonance caused by over-coupling. In order to design the fill transformer adequately, it was necessary to calculate the attenuation curves over the top bandpass very carefully. The method of McCoy was used.

After the composite curve for the four over-coupled transformers was obtained, a graphical method was used to find the optimum coupling and Q for the fill transformer to give the flattest overall curve. In this method, selectivity curves are plotted on log paper, and a comparison which is independent of Q values is made by moving curves along the frequency axis. After a suitable match of shape is found, i.e., the valley matched to top of the fill transformer, then the relative Q relation is determined by how far one curve has been moved in relation to the other. In this manner, a satisfactory design was established.

---

<sup>2</sup>R.E. McCoy Envelope Delay in D-F receivers  
Technical Memorandum M-1009, Sept. 20, 1946

Courtesy of <http://BlackRadios.terryo.org>

The following chart gives the final design constants for the five IF transformers,

TABLE III

Traf.	2 kc		4 kc		8 kc		16 kc	
	Q	K/Kc	Q	K/Kc	Q	K/Kc	Q	K/Kc
T-1	125	0.9	125	0.9	87	0.5	60	0.5
T-2	125	0.6	125	1.0	88	2.0	68	2.2
T-3	125	0.6	125	1.0	88	2.0	68	2.2
T-4	125	0.6	125	1.0	88	2.0	68	2.2
T-5	125	0.6	125	1.0	88	2.0	68	2.2
T-6	26	0.9	26	0.9	26	0.9	26	0.9

$$Q = \frac{wL}{R} \text{ for both primary and secondary}$$

$$K/Kc = KQ = \frac{M}{L}Q$$

M = mutual inductance

L = inductance of primary and secondary

Notes: (1) Final transformer have unequal Qs. However this chart gives the equivalent equal Q transformer.

(2) Transformer T-6 above is designed to feed the diode load, while not appreciably attenuating the top bandpass in the 16 kc position.

(3) Transformers remain in the 2 kc position for the 0.1 and 1.0 kc crystal filter positions.

### Crystal Filter

The crystal filter and associated circuit was designed by Bob Craiglow of Collins Radio Company. It is a conventional design except for the method used to obtain sharpest bandwidth. Instead of the crystal working into a low resistance load, it feeds into a capacitor. By this means, the full Q of the crystal is realized, and at the same time, a reasonable output is obtained. The crystal frequency is pulled slightly, but not enough to cause trouble. The 1 kc position was obtained by adding additional resistance in series with the crystal to lower its Q.



## Courtesy of <http://BlackRadios.terryo.org>

### Circuit Considerations

The actual circuit layout with tubes, resistors, etc. was designed mostly on the basis of laboratory experiment. It was found that the fill transformer, T-1, should be placed first in the line-up. Otherwise the rise in gain on each side of resonance (about 9 db) could overload the last stages before the fill transformer. Also the change in gain between 4 kc (max. gain) and 16 kc (min.) positions had to be compensated. This was accomplished by switching cathode resistors in two stages of amplification.

Amplifier layout was conventional with the usual number of decoupling resistors and capacitors. High quality components were used throughout. Size of bypass capacitors was more than adequate. No trouble with regeneration was encountered as a result of good isolation between stages and between input and output. Several tubes were tried for 455 kc amplifier use. Final tube decided upon was a 6BJ6, a remote cut-off pentode with 150 ma 6V filament. The last IF amplifier tube was chosen to be a 6AK6. This tube provided the large signal input capacity necessary to meet a specification calling for the output to be linear with 20 db signal increase from normal level, MGC position.

In Figure 57 is a simple block diagram of the main components.

Overall gain required was determined by needs of RF section and audio. Final value was 200 uv input for 7 vdc on detector. Gain could be varied by means of gain adjust pot between 10,000 and 100,000. As can be seen on the block diagram, all tubes serve as both amplifiers and gain control devices except the final amplifier (6AK6). This would make it difficult to eliminate one or more tubes by capacity coupling between transformers. Nevertheless, it was found experimentally that 22 uuf top capacity coupling between transformers would be satisfactory (no appreciable change in selectivity) if a resulting 20 db loss in gain could be recovered.

An external IF output is provided for teletype use. Nominal impedance is 60 ohms and normal output is around 50 millivolts. This is provided by a cathode follower which is fed from the grid of the final IF amplifier. The BFO is effectively isolated from this output by the final IF tube (6AK6). Output voltage must be linear from 20 to 200 mv out. The cathode follower tube (1/2 12AU7) must operate near maximum ratings to obtain 0.2 volts at 60 ohms impedance.

#### 4.2.4.4 Transformer Design

A previous Table gives the design constants for the five IF transformers. Some method of variable coupling had to be found which would be adjustable from the front panel and yield the desired change in coupling. The following table gives the range of coefficient of coupling K involved for each transformer:

Courtesy of <http://BlackRadios.terryo.org>

TABLE IV

<u>Traf.</u>	<u>2 kc K</u>	<u>4 kc K</u>	<u>8 kc K</u>	<u>16 kc K</u>
T-1	.0072	.0072	.00575	.0084
T-2	.0048	.008	.0228	.0324
T-3	.0048	.008	.0228	.0324
T-4	.0048	.008	.0228	.0324
T-5	.0048	.008	.0228	.0324
T-6	.0345	.0345	.0345	.0345

$$K = \frac{M}{\sqrt{L_1 L_2}}$$

M = mutual inductance

L<sub>1</sub> = inductance primary

L<sub>2</sub> = inductance secondary

Note: These values are again based on the equivalent equal -Q transformer.

#### Variable Coupling Methods

Several methods of variable coupling were investigated both theoretically and practically. A ratio of at least 7/1 was needed between maximum and minimum coupling, as shown in Table IV. Remember that this refers to the actual physical coupling, which is independent of Q values.

Top capacity coupling is used sometimes to add to the inductive coupling between IF coils. It has the advantage of simplicity and ease of application. However, it has two serious drawbacks which prevent its use here. One is that if top capacity is used to provide most of the coupling at high coupling factors, the selectivity curve will be inherently asymmetrical<sup>1</sup>. The other defect is that in switching between several capacitors to provide variable coupling, the coils are detuned with each change

<sup>1</sup>Raditron Designer's Handbook, 3rd Edition, P. 125.

Courtesy of <http://BlackRadios.terryo.org>

in top capacity. This last defect is present in several variable coupling systems, and prevents their use. Also, high impedance switching, which would be necessary, presents a design problem in high gain amplifiers. Careful placement of leads and switches must be observed or regeneration trouble will be encountered.

Bottom resistance or reactance coupling was investigated also. This means placing a common impedance in the cold end of primary and secondary coils. The common reactance method has the same drawbacks as top-capacity coupling, except that high impedance switching is avoided. Bottom resistance coupling was investigated experimentally, since little could be found in the literature. It was found impossible to obtain even critical coupling with this method. Evidently the common resistance lowered coil Q faster than it provided tighter coupling.

The most basic method of varying the coupling between two coils is moving them physically in relation to each other. This method is the most direct and easiest to understand of all the schemes. Where a powdered iron core is used, the whole coil and core assembly must be moved together in order to avoid the serious defect of detuning. Even then, it is hard to avoid some change in tuning because of stray capacity to shield can, spacers, etc.

Two possible drawbacks are found in this system. Mechanical construction is complicated and to meet the particular requirement of four distinct coupling positions would require an accurate cam and detent arrangement. This is difficult, but could be done. Perhaps the more serious objection is difficulty in obtaining the 7/1 coupling change required for this design. One such transformer constructed experimentally had a coupling change ratio of 3/1, which would still not be sufficient for the requirements.

Another possible method is variable stagger-tuning. Stagger-tuned coils could be arranged to give the same overall selectivity requirements. Selectivity could be changed by switching fixed capacitors across the staggered pairs. This method was not investigated because of complicated calculations and the need for isolation between coils (more tubes). Indications were that this method would be better suited to high frequency IF strips.

The first method tried and actually used for a complete set of transformers, was a tapped link arrangement. A sketch of the transformer is shown in Figure 58.

In the diagram,  $L_1$  and  $L_2$  are iron core tuned coils with powdered iron cups around each coil.  $L_x$  is several turns of wire wound inside the iron cup for  $L_1$ .  $L_x$  and  $L_1$  are coupled tightly.  $L_1$  and  $L_2$  have enough coupling to provide the first of four coupling positions.



This construction and method has several distinct advantages. The switching is done on the cold end of the secondary only. This makes layout uncritical. Series resistors  $R_1$  and  $R_2$  can easily be inserted to lower the  $Q$ , and mechanical construction is straightforward. The only critical item is where the taps are placed on  $L_x$ . This determines the change in coupling between positions 1, 2, 3 and 4. A relatively large range of coupling can be obtained by adding more turns to  $L_x$ .

The big disadvantage, and what finally disqualified the system, was change in tuning of the secondary by switching more turns in series with  $L_2$ . This causes the double humps in the over-coupled positions to be lopsided. In one transformer the effect is not too pronounced, but when four or five are added together, the effect is so great as to make it impossible to obtain a flat topped overall response curve.

Various systems were tried to compensate for detuning. One was to switch in a series condenser for every new coupling position to compensate for the change in inductance. This was successful, but the added components made it somewhat impractical.

The system finally used was an outgrowth of the tapped link inductance. To change coupling, it was decided to change the coupling of  $L_x$  in relation to  $L_1$  by changing the spacing.  $L_x$  was placed outside the iron cup surrounding  $L_1$ , and moved up and down the coil form to vary coupling, while keeping the inductance of  $L_x$  constant. Several practical difficulties were encountered, but overcome in the final version.

#### Physical Construction of Transformer

The interstage transformer shown in Figure 60 having four separate values of coupling will be discussed first. T-1 and T-6 in Table IV were an outgrowth of T-2 thru T-5 (interstage transformers).

The coupling coil,  $L_x$ , discussed in the last section is now coils A, B, C, and D, Figure 3. Each coil has the same inductance, but varies in its coupling to  $L_1$  due to its physical spacing. Each link corresponds to an overall coupling factor for the transformer. The primary tuning core goes through all coils A, B, C, and D to provide higher coupling to primary  $L_1$ . Note that this core is connected to its adjusting screw through a phosphor-bronze wire. This wire causes little loss in  $Q$  in the primary. A brass stud would de- $Q$  the primary considerably.

The powdered iron half-shells serve several purposes. One is to increase the inductance of  $L_1$  and  $L_2$ , which means that fewer turns are required. They shield the coils from external fields. This is quite important, because in the completed IF strip, the transformers are mounted as close as possible to each other to save space. The primary iron cup serves to shield the links from the secondary.

Courtesy of <http://BlackRadios.terryo.org>

Wire used for the main coils is No. 30 x 44 SSE Litz. This gives a high Q for the relatively few turns used (83). Small links are 8 turns of No. 30 DE wire. Powdered iron parts are all carbonyl E basic material. This is a high Q, low permeability iron. Phenolic parts are made of the best electrical grade of paper base phenolic available at the time. Collins Specification No. 278 0103 00 describes the mechanical and electrical specifications in more detail than will be covered here.

The original design called for the main coils to be mounted coaxially. This had the disadvantage of having one tuning adjustment below the chassis. Shield can size on the first transformer was 2-1/2 inches high by 29/32 inch square. To enable both tuning adjustments to be made from the top, the construction of Figure 3 was used. Shield can size is 2-1/2 inches high by 1-7/16 inches square.  $\sqrt{31}$

### Coupling System

The final variable coupling system will now be explained in more detail. A system that will give four positions of Q and K/Kc, as listed under Table III, transformer T-2, is the goal. Figure 58E shows the circuit for the transformer.

It was decided that for simplicity in switching, it would be better to lower the Q of the secondary only for the wide positions. This can be done easily by inserting resistors in series with the secondary tank circuit as shown in Figure 58B. The only requirement is that these resistors be non-inductive. The overall switch arrangement in Figure 58B is well adapted to the tandem switching of five transformers. All leads are near ground potential and are low impedance. No trouble was encountered with coupling between switch sections and the switch shaft, even though about 10 inches long, caused no trouble with coupling between input and output transformer.

The theory of designing an unequal Q transformer to be equivalent in selectivity and coupling to the equal Q design shown in Table III, was developed by J. E. Maynard<sup>1</sup>. Applying his methods to the transformer in question yields the following design:

TABLE V

Interstage Transformer T-2 Thru T-5

<u>Factor</u>	<u>2 kc</u>	<u>4 kc</u>	<u>8 kc</u>	<u>16 kc</u>
Q pri	125	125	125	125
Q sec	125	125	68	46.7
K	.0048	.008	.0235	.033
K/Kc	.60	1.0	2.1	2.5

$$K_c = \frac{1}{\sqrt{Q_p Q_s}}$$

<sup>1</sup>J.E. Maynard, Tuned Transformers. G.E. Review VOL 46, P. 559, Oct., 1943

Courtesy of <http://BlackRadios.terryo.org>

This transformer will have the same characteristics as transformer T-2 listed in Table III. It was found experimentally and by theory that unequal Q in primary and secondary produces no asymmetry in the response curves. The response is exactly the same in all respects as the equivalent equal Q transformer. Transformers can be checked on a Q meter or in an amplifier circuit for conformance with Q and coupling, providing that the values listed are used.  $K/K_c$  listed in this table is the quantity commonly called N or C, the ratio of actual coupling to critical coupling, that is measured by the following relation:

$$N = K/K_c = \sqrt{\frac{E_o}{E_t} - 1}$$

where  $E_o$  = primary RF volts with secondary open

$E_t$  = primary RF volts with secondary tuned

It was found also that a transformer with unequal Qs will have a higher stage gain than the equivalent selectivity equal-Q transformer. In the schematic of Figure 58B, the secondary output must be taken across the coil  $L_2$  to yield a symmetrical selectivity curve. If the output voltage includes the link voltage, i.e., output across  $C_2$ , then the selectivity curve will be asymmetrical especially at high coupling. Considerable work was done during the development on the unequal Q theory reviewed briefly in the preceding paragraphs.

It was found experimentally that there was not quite enough room between the primary and base board to place four links covering the coupling range involved. A solution was found in reversing the polarity of the 2 kc link C. This caused its coupling to oppose the main coil coupling and resulted in the desired overall K factor. In fact, it was found possible to obtain exactly zero coupling by moving link C about 1/16 inch further from primary than its present position. The range of coupling available then by this method is practically unlimited, depending on how many turns are on the links and whether they aid or oppose main coil coupling.

The particular coupling setup used was decided upon by experiment and by trying different combinations on paper. First of all, the links had to be spaced far enough from each other so that adjustment could be made without interference. The coupling desired between the two main coils had to be physically obtainable. Much work was done with an experimental transformer in which everything was movable. The optimum number of turns on the links turned out to be 1/10 of the main coil turns, i.e., 8 vs 83 turns.

The coupling between primary and secondary with no link in series worked out to be .0040. This is the actual coefficient of coupling

$K = \frac{M}{\sqrt{L_1 L_2}}$ . The additional coupling provided by links A, B, C, and D, either

Courtesy of <http://BlackRadios.terryo.org>

aids or opposes this original coupling. The following table lists various values of  $K_x$  shown in Figure 58A and the resultant overall coupling

TABLE VI

Interstage Transformer

	<u>2 kc</u>	<u>4 kc</u>	<u>8 kc</u>	<u>16 kc</u>
Main coil coupling, $K_{12}$	.004	.004	.004	.004
Link coupling $K_x$	-.0088	+.004	+.0195	+.029
Resultant overall coupling K	-.008	.008	.0235	.03

$$K_{12} = \frac{M_{12}}{\sqrt{L_1 L_2}}$$

$$K_x = \frac{M_x}{\sqrt{L_1 L_x}}$$

The last line agrees with the desired coupling shown in Table V. The minus sign has no significance in the final answer. It merely indicates that  $K_x$  opposes  $K_{12}$  in the 2 kc position. This table shows that link D (4kc) is the farthest from primary coil  $L_1$ . The fact that couplings are added and subtracted in this manner was shown experimentally.

Each coil, A, B, C, and D in Figure 58A has the same inductance. One-half turn was removed from coil A to keep its inductance the same. This was because it was under the iron half-shell, which tended to increase the inductance. The primary tuning core, which goes through all four links, helps to keep their inductance constant regardless of position.

Other Coils in IF Amplifier

The input transformer, T-1, of Table III and IV is the same as the interstage transformer in physical construction. However, the link spacings are varied somewhat along with Q values. Refer to Collins Specification No. 278 0102 00 for physical construction and schematic. It has three positions of coupling, and hence only three links. The following is design data for the input transformer T-1:



Courtesy of <http://BlackRadios.terryo.org>

TABLE VII

Factor	Input Transformer T-1			
	2 kc	4 kc	8 kc	16 kc
Q pri	125	125	125	125
Q sec	125	125	67	39
K	.0072	.0072	.006	.012
K/Kc	.9	.9	.55	.8
$K_{12}$	.004	.004	.00-	.00-
$K_x$	+.0072	+.0072	-.010	-.016
K overall	.0072	-.0072	-.006	-.012

Notice again that the link coupling in the 8 and 16 kc positions opposes the main coil coupling  $K_{12}$ . This is necessary because the 4 and 8 kc overall coupling are so close together. The 8 kc link is reversed in polarity in order to separate it physically from the 4 kc link. There is one peculiar effect resulting from reversing the link polarity. If the main coils are moved closer together, the effect is to increase the 4 kc overall coupling as would be expected. However, the 8 and 16 kc overall couplings are decreased by this operation. This can be understood by looking at the values of  $K_{12}$  and  $K_x$  in Table VII.

The output transformer is operated at one value of coupling and Q. Mechanical construction is the same as T-1 through T-5. The relatively high physical coupling,  $K = .0345$ , could be obtained in this design only by a link placed as in T-2, link A, the interstage transformer. Here the main coil turns equal 125 and link turns are 15. This transformer operates into a series diode load of 22K ohms.

The AGC amplifier and crystal filter circuits both use a high impedance single-tuned circuit. Here the iron half-shells are mounted open ends together to completely enclose the coil. The crystal filter unit is constructed with the crystal phasing control (3-12 uuf) and loading coil mounted in the same shield can.

There is a 455 kc transformer mounted on the RF sub-assembly unit which feeds into the crystal filter. This transformer presented a special design problem. The bandwidth had to be broad enough so that it did not attenuate the 16 kc selectivity curve appreciably. This required a Q of not more than 12 to 15 under operating conditions. The output coil was to be a center-tapped untuned link of about 1000 ohms impedance. Any

higher impedance would load the crystal filter too much, since this impedance is effectively in series with the crystal. A lower impedance would result in not enough gain from the last mixer grid to the first IF grid. The resulting design was a transformer with more turns on the output link than on the main coil. This is just the opposite from a conventional transformer used in this application.

#### 4.2.4.5 Practical Considerations

##### Transformers

From the start of the transformer design, it was realized that tuning had to be done in one BW position only, and that the selectivity curve had to stay on frequency and remain symmetrical when switching to any other position, otherwise, the receiver would have to be retuned between BW positions, and the signal might be lost in going from a wide position to a sharper one to eliminate interfering signals. This requirement meant that the tuning of the secondary of switched transformers had to stay right on frequency.

A further requirement was that each transformer could be tuned by simply peaking each iron core for maximum output voltage without the need of special tools or elaborate techniques. T-1 is tuned in the 8 kc overall position. This corresponds to its sharpest position. T-2 through T-5 are tuned in the 2 kc overall position. The output coil, T-6, is somewhat hard to tune because of low Q and high coupling. However, it can be tuned after several operations between primary and secondary cores. Tuning procedure for the crystal filter and AGC coil are also quite simple but require a tunable signal generator for setting the phasing condenser.

Electrical tolerances are covered in detail on the respective transformer specifications. The need for the relatively narrow tolerances of  $\pm 5\%$  and  $\pm 10\%$  is based on several factors:

- (a) Overall requirement for bandpass phase characteristic.
- (b) Change in selectivity curve symmetry with BW position.
- (c) Filling in the overcoupled humps to produce a flat selectivity curve top.
- (d) Original specification for bandwidth tolerance.

It has been determined both on paper and experimentally that if the individual transformer specifications are satisfied in each case, then the overall IF characteristics will be within specifications. Each individual specification has a short production testing procedure, which will insure that the transformer will operate satisfactorily in the complete unit.

## Courtesy of <http://BlackRadios.terryo.org>

Electrically the important quantities are bandwidth and coupling. The are particularly important in the direction finding position (2 kc) and in the over-coupled positions. For this reason, BW and coupling should be checked for production testing. Q and gain are not the important quantities in this case, and can only be checked as a type test.

Mechanical tolerances are entirely determined by the electrical specifications. It was found that if link spacings to primary coil are held within  $1/64$  inch, the electrical requirements could be met. Also spacing between main coils should be held to  $1/32$  inch and distance between coil form to .005 inch. Turn on links A, B, C, and D must be held at least  $1/4$  turn. Permeability of primary tuning core must be held to  $\pm 1\%$ .

### Overall Circuit

Some trouble was encountered with the switches used to change bandwidth. After being used for several months, or particularly after a humidity run, the switches would show enough contact resistance to cause erratic operation. Resistance on the order of one-tenth ohm will be enough to change the secondary Q 5 to 10%. Switches with double contacts (front and rear in parallel) were finally used. Rotor is solid coil silver and clips are silver alloy. No more trouble was encountered with this type construction.

With six amplifier stages in tandem, it was necessary to control the gain from set to set by using a variable potentiometer in one cathode circuit. This pot is adjusted to the correct overall gain at the time IF strip is first tested. Another problem was the change in gain between BW positions. This is compensated for by switching cathode resistors common to two stages. However, since each transformer can vary  $\pm 15\%$  in its gain, the gain between bandwidth positions could vary 7 to 8 db or more. This is provided for by possible selection of individual gain control resistors, if necessary, in final test of the IF strip.

There is a nominal 2700 ohm resistor in series with the 455 kc crystal. This can be changed in test to adjust the bandwidth in the 100 cps position. This was necessary because of crystal activity (Q) variation from different manufacturers.

### Summary of Measurements

The last three complete IF units built up to September 23, 1952, were measured for performance according to a standard procedure. Data was recorded on uniform data sheets for convenience in comparing units.

In the first unit, the 0.1, 2 and 16 kc bandwidths were slightly wide. In the second, only the 2 kc BW was slightly wide. In the last unit, all positions were within specifications. Windings were dimensioned according to a standard when given to the coil winding department. Peak-to-valley ratios were all well within specifications.

Courtesy of <http://BlackRadios.terryo.org>

BFO range was slightly off on one unit. This was corrected. Inter-modulation distortion was out of specifications on all units. The specification figures were based on the first IF strip built. Several changes were made in tube operating conditions since that time which evidently caused this characteristic to be slightly worse. Direction finding characteristic was out of specification in all units. However, it was decided that the 1/4 degree tolerance was not possible. All units met  $\pm 1$  deg tolerance which the Signal Corp indicated might be acceptable.

BFO leakage at 60 ohm IF output was out of specification if a change in frequency of  $\pm 3.5$  kc was included. Neutralization could be made at one frequency, but did not hold very well over the range of frequencies involved. This specification should be investigated, especially as to method of measurement. All other items measured were within specification on the three units.

#### 4.2.4.6 Service Conditions

##### Impregnation Against Humidity

Protection of high Q, high impedance coils against humidity is always a problem, particularly in an IF transformer where coils consist of many turns built up into a large pi. In this case, coils had to meet a 48-hour soak at 95% relative humidity at temperatures from 20 deg C to 65 deg C. Measurements were to be made with coils actually in humidity chamber. No numbers were written into this specification, but it was decided to try for the best possible and practical method for protection.

The problem is to keep moisture out of the coil. If it penetrates, the Q of the coil drops as well as a change in tuning. This is due to one or all of the following factors:

1. Dielectric losses of water.
2. Change in tuning because of change in dielectric constant of water over air, or change in permeability of iron core.
3. Lowering of impedance between strands of Litz wire and between adjacent turns because of moisture penetration through varnish on wire, or through contact at pinholes, etc.
4. Eddy current losses in water.

The third item was demonstrated by separating the strands of 30 strand Litz wire into two groups of 15 strands each. A DC resistance measurement was made between these two sections for testing. At room conditions the resistance was on the order of 100 megohms. Immediately upon dipping an insulated section of wire into water, the resistance would drop to a



Courtesy of <http://BlackRadios.terryo.org>

magnitude of 100 K to 1 meg. It would then continue dropping slowly. The new nylon-enamel wire (Dipsol, etc.) was very much worse in this test. Even teflon covered (Ceroc) wire was very poor. This last was probably due to cracks or pinholes in the insulation.

The following commercial preparations were investigated for possible use as impregnants. Those that were actually tried are indicated by an asterisk.

1. Cycleweld 55-9 cement, Chrysler Corp.
2. EC870, polychloroprene base compound 3-M Co.
- \*3. 3-M casting resin R-1433.
- \*4. Durez 14139, phenolic thermosetting resin.
- \*5. Q-322 wax, Zophar Mills.
- \*6. C-770 wax, Zophar Mills.
- \*7. Plaskon ST-856, silicone alkyd resin, Libby-Owens-Ford Glass Co.
- \*8. MR3738, potting wax, Mitchell-Rand Insulation Co.
- \*9. MR3784, dip coating wax, Mitchell-Rand Insulation Co.
10. Acme Star Compound, Acme Wire Co.
11. Penacolite Adhesives, Koppers Co., Inc.
12. NBS casting resins.
- \*13. DC935 silicone resin, Dow Corning Corp.
- \*14. Araldite Casting Resins B, D, F, G, Ciba Company.
- \*15. Araldite adhesives 11, 15, type 1, 101, Ciba Co.
16. DC996 silicone resin, Dow Corning.

The waxes and the casting resins both worked very well in protecting against moisture. All the waxes were for high temperature use. However, since they are thermoplastic, they will always melt or run at a high temperature. The highest temperature wax tried was MR3738, which required application at 160 - 180 deg C. Waxes all gave very good penetration.

Complete details on how the coils were tested would be too lengthy to include here. The whole subject of impregnation would require a separate report. Of all the compounds tested, Araldite Resin F, now called CN-503, had the greatest number of desirable qualities.

Courtesy of <http://BlackRadios.terryo.org>

1. Thermosetting - will not melt or run under any temperature.
2. Temperature range outstanding (no cracking at -62 deg C).
3. Simple application by hot dipping.
4. Extreme fluidity - viscosity of water with a wetting agent when applied.
5. Excellent penetration without vacuum techniques.
6. Outstanding adhesion to metals and plastics.
7. Gluing and impregnation in one operation.
8. Very good resistance to water and moisture.
9. Hardly any shrinkage with curing (0.5 to 2%).
10. 100% solids. No solvents.
11. Coil form inside can be dipped without appreciable build up of resin.
12. Iron cores can be impregnated with minimum increase in diameter.

Disadvantages:

1. Two compounds to be mixed before using.
2. Long cure at high temperature (10 hours at 130 deg C or 48 hours at 100 deg C).
3. Pot life of resin is limited because of thermosetting properties (6 hours at 120 deg C).
4. Parts must be hot dipped (above 60 deg C). This is an advantage in some cases.

The last three IF units had coils impregnated with Araldite CN503. Coils were tested under humidity by operating them as a complete IF amplifier on a special test chassis, the same as is used in the complete receiver. The following table summarizes the results of testing. Gain measurements were made immediately upon removing chassis from test chamber. Figures represent microvolt input level to all six stages in tandem for standard output.

Courtesy of <http://BlackRadios.terryo.org>

IF Unit	Input (Before Cycle)		Humidity Cycle	Input (After Cycle)	Input After Returning
R390 #4	2 kc	95	6 days SC-D-15914	250	210
	16 kc	57		83	80
R389 #3	2 kc	55	48 hrs JAN-R-95	400	150
	16 kc	30		47	33
R389 #3	2 kc	55	65 hrs JAN-M-745	150	140
	16 kc	30		36	36
R390 #4	2 kc	22	4 days SC-D-15914	150	65
	16 kc	21		41	35
R390 #4 Primary cores impregnated	2 kc	52	4 days JAN-R-93	260	92
	16 kc	44		43	45
R390 #4, both primary & sec. impregnated	2 kc	52	4 days JAN-R-93	78	70
	16 kc	41		46	43

The amount of detuning of transformers was found mostly due to change in iron core permeability (after coils were impregnated). This was shown by impregnating half the iron cores in the unit. After humidity run, the cores that were impregnated needed very little adjustment for tuning. Cores with nothing for protection, were consistently off tune by one or two db. This is not much per stage, but with six stages, the effect is quite noticeable.

#### Vibration and Temperature

Complete IF unit performed satisfactorily under vibration testing. The resin used for impregnating provides an excellent supporting agent for coils and powdered iron cups. It is flexible enough not to break under shock and vibration if leads are not too short between gluing points. At least two 6BJ6 tubes failed on the package tester machine and burned out the stage decoupling resistor. This should be checked if it happens again.

Temperature tests were conducted on the last three IF units. Data showed that the center frequency in the 2 kc position shifted about 1.5 kc from -40 to +60 deg C, with a reduction in gain of about 8 db. This is maximum change of the transformers in the sharpest position. The 1 kc shift in peak frequency was about 0.75 kc over the same range with a reduction in gain of the same magnitude. The 0.1 kc position peak shifted about 150 cps over -40 to +60 deg C. Gain again changed about 6 db. This was with no temperature compensation in IF transformers.

Courtesy of <http://BlackRadios.terryo.org>

Production specifications on each transformer call for less frequency shift than transformers made so far have shown. This would require temperature compensating condensers and should result in the overall frequency shift being about half the shift shown above.

Production TestingTesting Each Transformer

The specification for each transformer calls for production testing by checking the bandwidth at one attenuation point and coupling. The most accurate way to check these quantities is with the conventional signal generator, frequency meter, and output meter method. However, this method does not lend itself well to high speed production testing.

Another method which is not generally as reliable, makes use of a calibrated sweep generator and CRO for observing the selectivity curve. It is hard to measure actual bandwidths this way, and next to impossible to measure coupling of an undercoupled transformer. However, as soon as the transformer develops double humps by overcoupling, the measurement becomes feasible. The peak-to-valley ratio is a very accurate method of measuring relative coupling. The distance between humps, which is usually quite distinct, gives the bandwidth required. These two quantities, peak-to-valley ratio and bandwidth between peaks, describe the transformer very accurately, and can be the basis for close control.

The catch here is that a transformer that is undercoupled cannot be checked accurately. It can be shown, and is discussed by Terman<sup>1</sup>, that the voltage versus frequency curve across the primary side of a double tuned transformer exhibits double humps before the secondary side. In fact, the transition between one hump and two humps occurs at a relative coupling of about 0.55 times critical. If a cathode follower is fed with the primary voltage and the output of the follower rectified and fed to a CRO, the resulting selectivity curve will exhibit just such action.

This setup was tried experimentally with success. The interstage transformer with 0.6 times critical in the 2 kc position showed double humps on the primary side. To establish what the peak-to-valley ratio and bandwidth between peaks should be on the primary side, it is necessary to measure the transformer conventionally for compliance with specification; then measure the primary selectivity curve.

The following setup was tried for a possible production test setup: A sweep generator was fed to two transformer test circuits in parallel. One transformer was the standard and the other under test. The outputs

---

<sup>1</sup>Terman, F.E. Radio Engineering, 3rd Edition, P. 58.



Courtesy of <http://BlackRadios.terryo.org>

were rectified for DC and fed to an electronic switch. The output of the switch was observed on a scope. In this manner the calibration is dependent only on the standard transformer and relative channel gain. It is independent of sweep width, frequency or slight non-linearities that can occur in such a system. The gains are adjusted to be the same through each channel and the two curves compared directly as to peak-to-valley ratio and bandwidth between peaks. If necessary, output is taken from the primary side of the transformer to obtain double humps. With this method, changes on the order of  $\pm 5\%$  in BW and coupling can be observed easily. However, a means for establishing maximum and minimum limits still is a problem. One solution is to modulate the standard curve at about 50 kc. This effectively widens it vertically and can serve as a sort of tolerance limit. It is felt that this method is a solution to the problem of production testing IF transformers.

#### Testing Complete Unit

Production testing of the complete IF amplifier has not been decided upon. Complete engineering tests for each unit have been set up and a data sheet made. These include service conditions tests. The last three IF units have had complete data taken.

#### 4.2.5 R-389 RF

During the planning stage of this contract, the general physical layout of both the R-389 and R-390 had been determined. This resulted in a definite limit as to the size and shape of the RF sections and since the R-390 portion was about two months ahead of the R-389 in development it meant that little or no compromise in size could be made. Later in the program it appeared to be somewhat of a handicap to make the two receivers so similar in layout, but at this point the R-389 RF had to be designed into the prescribed space.

The primary determining design factor was the specified 455 kc IF amplifier. This forced several immediate conclusions -

1. The circuit must be a multiple superheterodyne.
2. The RF tuning range would pass through the IF frequency.

The very accurate tuning and stability requirements imposed many restrictions on the electrical and mechanical design. The major mechanical problems in this category were providing a frequency indicator of sufficient accuracy, and coupling the frequency indicator with a sufficiently small amount of backlash to the variable frequency oscillator.

Electrical stability was determined by the oscillators to be used. The VFO was required to provide linearity as well as stability, and any other oscillators used in conversion would be required to meet stability specifications.

Courtesy of <http://BlackRadios.terryo.org>

The need for tuning through the IF frequency (455 kc) had determined the necessity of a double superheterodyne. In addition adequate shielding would be necessary. Reduction of spurious and image would also require a first IF frequency several times greater than the highest signal frequency.

#### 4.2.5.1 The Signal Path

The initial considerations had pointed to the need for a double superheterodyne. The signal path would then be as shown in Figure 61A.

In most receiver designs, RF selectivity would be designed for maximum. However, due to the low frequencies involved, and the relatively wide pass bands required, it was necessary to design the R-389 R-F circuits a pass band rather than for maximum selectivity (i.e. 8 kc pass band at 115 kc.).

To further control the spurious response, it was desired to limit the maximum RF voltage on the first mixer grid under strong signal conditions. Two RF amplifier tubes with AGC were used for this purpose. One tube would have been sufficient to provide the desired signal-to-noise ratio.

The number of RF coils used was set at 4. This would provide an antenna coil, first RF plate, and a coupled circuit for the second RF plate. The double tuned circuit was placed in the plate circuit of the second RF amplifier to reduce the amplitude of harmonics generated in the tube and subsequently coupled to the first mixer. This was a spurious response consideration.

The most obvious spurious response is produced by the signal frequency harmonics falling on the first IF frequency. Past experience had shown that these responses should not be lower than 6th or 7th order if adequate attenuation is to be obtained. The highest signal frequency is 1500 kc and  $7 \times 1500 = 10,500$ . Thus, if a 10,000 kc IF were used the lowest order harmonic spurious would occur at 1428.6 kc and would be the 7th order. Accordingly, the first IF was selected at 10 mc. This selected frequency scheme also limited cross over spurious to the 7th order.

The injection frequencies were now determined. Injection to the last mixer would be either 9545 kc or 10,455 kc. The first mixer injection would be 9985 kc for a 15 kc signal and 8500 kc RF signal.

#### The Injection Path

The primary problem in supplying the injection voltages lay in the stability requirement. The situation is aggravated by the fact that both injections are several times higher in frequency than the signal.

The first injection frequency range is 8500 kc to 9985 kc. A variable frequency oscillator operating directly on this frequency would fail to provide either the desired calibration accuracy or stability. The second injection frequency stability would also be marginal even with the best crystal and ovens available.

Courtesy of <http://BlackRadios.terryo.org>

It was decided that the stability problem could best be solved by providing a ring circuit in which the drift of the second injection would be completely canceled. This would also enable the variable frequency oscillator to operate at a frequency nearer to the signal frequency. Such a scheme placed the second injection frequency at 10,455 kc.

Early in the development it had been considered desirable to provide a dial system presenting 100 kc segments up to 500 kc and then cover the broadcast band in one sweep. This scheme would permit the use of a slide-rule type dial presentation. Without further comment the conversion system proposed was as shown in Figure 61B.

This system provides an injection range at the first mixer of 10,000 to 8400 kc which gives an RF input range of 0 kc to 1600 kc.

A breadboard model of this system was constructed. Spurious responses due to the low frequency crystal fundamental and harmonics was of a great enough magnitude so that considerable improvement was in order. Due to the pressure of time the system was reconsidered. Spurious responses were further examined (Reference Data for Radio Engineers, 3rd edition, pages 455 - 458) and the conversion system modified to be as shown in Figure 62A.

This system was tried on the breadboard and by substituting a signal generator for the VFO, tests were made. The results were very encouraging.

A request for a six-band oscillator was presented to the oscillator department. It was their opinion that while the oscillator could probably be built, the predetermined space allotment and the limited time available would prohibit the project.

The good features of the frequency scheme proposed for use with the six-band oscillator indicated that the basic system should be retained if at all possible. This could be done if the decade dial system were dropped and a continuous system used whereby the oscillator would tune a range giving an RF input of 15 kc to 500 kc in one sweep. This could be accomplished if the oscillator tuned from 470 kc to 955 kc. It would then be possible to tune the broadcast range by using the second harmonic of the oscillator and extending the high range to 977.5 kc. To provide overlap and have a tuning range of 14 kc to 1505 kc the oscillator should tune from 469 kc to 980 kc. The conversion scheme is as shown in Figure 61B.

The 469 kc to 980 kc oscillator was developed under nomenclature 70H1. This oscillator had solved the frequency scheme problem; however, additional design considerations were presented as a result. Tuning the front end in two continuous sweeps - 15 kc - 500 kc and 500 kc - 1500 kc - presented several problems.

Courtesy of <http://BlackRadios.terryo.org>2.5.2 Practical Design ConsiderationsThe Signal Path

The decision to cover the frequency range in two sub-ranges pointed out the utility of a counter as a frequency indicating device. A counter is linear in presentation and so the variable frequency oscillator and drive shaft to the RF section must have linear responses with respect to frequency. Investigation led to the design of RF coils that would have a resonant frequency varying linearly with core insertion.

Without going into design details it may be said that the shortest possible core travel that could be used to give approximately at 2 to 1 frequency coverage was 1-1/4 inches. A 1-3/4 inch core was used. Coils were designed 1-1/2 inches long. At higher frequencies a lesser travel could be used due to the smaller effective diameter of solenoid coils.

It was shown at the start of the development that one serious short coming of conventional low frequency receivers lay in ringing during transient surge reception. It was felt this could be minimized if the Q and impedance of the RF coils were held to the minimum usable values. Computations considering the following led to the selection of values:

1. Minimum antenna gain necessary to obtain sensitivity.
2. Q versus bandwidth consideration.
3. Stage gain.
4. QX limitations as determined by physical coil size.

The QX was set at approximately 5000 ohms and the Q factor from 4.5 to 30. The lowest Q occurs at 115 kc and the highest at 1505 kc.

In designing individual coils three necessary factors were kept in mind:

1. Linear frequency versus core insertion.
2. Linear frequency versus Q relation.
3. Impedance.

The reason for the linear tuning has been mentioned before. The linear frequency versus Q relation gives a constant gain over each band. The impedance value as determined by the 5000 ohm QX set the inductance. It is interesting to note that the lowest frequency coil is resonated with a .02 microfarad capacitor. The highest broadcast coil is tuned with 620 micro-microfarads.



Courtesy of <http://BlackRadios.terryo.org>

Each of the RF coils is wound with pie windings in series, each of a number of turns as determined by the desired linear curve. The lowest frequency band coil contains 10 pies, all other coils have 12. Various sizes of Litz and solid wire are used as determined by Q. Each coil is trimmed by a variable inductance trimmer. It was decided to provide a trimming range of  $\pm 4\%$  and the values of capacity required to do this would be prohibitive. In addition, a permeability tuned coil is more effectively trimmed by a series inductance trimmer than by a shunt capacity trimmer. However, some loss of incremental permeability is incurred.

The complete frequency range was divided into seven bands as follows:

14 - 28 kc	250 - 505 kc
26 - 56 kc	495 - 870 kc
54 - 120 kc	865 - 1505 kc
115 - 245 kc	

As it had been decided to use four RF coils per band, the total number of RF coils added up to 28. The room available prohibited adequate spacing between the coil and shield can. This plus the need for all the available tuning range dictated the use of powdered iron sleeves as magnetic shields. These sleeves then permitted the electrostatic shield can to be placed directly next to the sleeve without serious effect on the coils.

The development of powdered iron cores for this frequency range represents a project in itself. It was not difficult to obtain cores possessing sufficient permeability and loss characteristics above 100 kc, but the lower frequencies presented what looked like an insurmountable problem. The iron core companies approached on the problem had given up on the lower frequencies. Powdered iron did not exist with losses high enough to lower Q as the core was inserted into the coil.

Experiments at Collins met with various degrees of success. A build-up of transformer iron laminations possessed sufficient permeability but the losses were too great. The Q factor would all but disappear at about 1/4 full insertion. A composite core was made by gluing transformer laminations of various lengths to pieces of powdered iron cores. It was found that by selecting the lengths of powdered iron and laminations that a wide variety of Q effects could be obtained. By using various lamination materials - Audio "A", oriented silicon, etc. - the effect was further controlled. Unfortunately time was not available to develop means of producing a core of this type in quantity.

Abandoning the composite iron core, the lowest frequency cores available (100 kc) were modified by wrapping copper bands around them at various intervals. By varying the position of the bands, the number used, and their width, it was possible to control the Q. Here again the production possibilities appeared negative. A solution was secured by coating

Courtesy of <http://BlackRadios.terryo.org>

the cores with bands of a silver conductive coating. Dupont 4817 was used, and a typical coil and core can be seen in Figure 15. This does not produce an absolute linear curve, but is sufficiently close for this application. This core can be produced in quantity.

A remote control pentode was selected for the RF amplifiers. The reasonably quiet 12BA6 was used in the first development set and changed to the nearly equivalent 6BJ6 as a result of heat considerations. The balanced antenna input was specified as 125 ohms. Previous mention has been made of the QX being partially determined by sensitivity requirements. The antenna gain is approximately 5. A calculation was made for each end of each band and for each unbalanced antenna impedance combination. This showed that only at the highest frequencies, with the highest antenna impedances, and highest capacitive antennas could over coupling occur if the antenna was connected directly to the top of the coil. Highest gain resulted from this connection, being as high as 224 at 28 kc but showing a net of 2.53 due to mismatch. At 1500 kc with an antenna of 1000 micro-microfarads and 0.1 ohm the net gain is 64.3. This antenna would be very rare. Had over-coupling been possible in many cases, it would have been necessary to use a different series matching capacitor on each band.

In order that the antenna impedance remain constant over each band, it was necessary to provide a link of unusual construction. On the two lowest bands the link winding is wound directly on top of the main winding and is a pie type coil. The impedance is held constant by providing more than one pie at strategic locations and of an appropriate number of turns. The design of such a device is done by experimental methods only. The higher band links are solenoids wound on bakelite forms which in turn slip over the main coil winding. Here again the placement of turns is varied to hold the impedance constant. Electrostatic shielding is obtained by coating the inside of the link form with a silver conductive paint and grounding the shield thus formed. There is of course an open strip in this coating.

The specified balance ratio of 500 to 1 was secured by connecting a fixed capacitor from one end of the antenna link to ground. This capacitor is not needed on all bands.

The tracking of the RF coils is a function of both electrical and mechanical tolerances. The design was such that the overall tracking error should be held to less than 1.5 db. This is at room temperature and normal climatic conditions. It is felt that in production variable pitch progressive universal windings will improve this error or at least make it easier to maintain.

The two coils in the plate circuit of the second RF amplifier were top coupled by capacity. In order that the gain of the coupled system vary as little as possible over the band, the coupling was set at 0.66 at the low frequency end. This gave a coupling factor of 2.0 at the high frequency end and the gain variation was 1.0 db. The over-coupled condition of these coils was found to adversely affect the direction finding bandpass phase shift characteristics.

Courtesy of <http://BlackRadios.terryo.org>

During the tests made at Coles Laboratory on the first receiver, it was found that the cross-modulation characteristics of the receiver could stand improvement. The effect was particularly bad when using an unbalanced antenna which essentially swamped the antenna coil. As a result it was decided to place two coils in front of the first RF grid. This eliminated the coupled circuit in the plate circuit of the second RF amplifier; and, of course, opened up the possibility for more harmonic distortion from this tube reaching the first mixer grid.

It was found that if the two coils were placed in the first RF grid circuit and top coupled by capacity, the antenna input impedance fluctuated wildly. A very small tracking error in either coil would throw a large reactive component into the antenna circuit. Final consideration replaced the capacity top coupling with resistive top coupling. With such a circuit over-coupling is impossible. Unfortunately there is a voltage loss and sensitivity suffered accordingly. The 10 db, 30% modulated, signal-to-noise ratio dropped from 3 microvolts to 6 microvolts at an 8 kc bandwidth. Tests made with the Signal Corps showed the improvement in cross-modulation worth the loss in sensitivity.

It was necessary to devise some system for switching the RF coils. In the low frequency range - 15 kc to 500 kc - five RF bands are used. In the high frequency range - 500 kc to 1500 kc - two RF bands are used. Just how to switch these bands at the right time presented a major problem. A mechanical system to do this would be a monstrosity since variable overlap would have to be provided. An electromechanical device was finally incorporated to perform this function. Reference to the mechanical drive shown in Figure 71 will provide full information. Briefly, the operation is as follows:

1. Rotary information from the oscillator shaft is supplied to an electrical commutator coupled thereto. On this commutator the gaps represent overlap and the segments RF bands. Two commutators are used; one for each range.
2. The commutator is connected to a selector switch section in the bandswitch assembly. This switch controls a motor which rotates the bandswitch when energized.
3. The motor stops when the proper band is switched into the circuit.
4. The operator selects one of two ranges - 15 kc to 500 kc or 500 kc to 1500 kc - the appropriate commutator being switched into the circuit for each range.

The second RF amplifier plate coil is similar to the antenna coil in its link construction. A different turns and winding data is used and there is no static shield.



Courtesy of <http://BlackRadios.terryo.org>

A triode first mixer was chosen because of the superior noise resistance characteristics. This determined the necessary gain of the RF amplifier stages. An approximate gain of 5 from the first RF grid to the mixer grid was needed. Since the 6BJ6 and a 5000 plate load can produce a gain of about 20, the output was resistance divided before being coupled to the second grid. The net gain - grid to grid - was then 3.5. The gain of the second RF stage grid to the mixer grid was centered at 1.5. The first RF gain was made higher than the second for noise considerations.

The second mixer is a pentagrid (6BE6) which has a high noise resistance. There is no IF stage between the two mixers; only a coupled circuit. This transformer is approximately 100 kc broad at the nose with 0.6 coupling, giving a stage gain for the first mixer of approximately 2.

The second mixer plate load is tuned and has an untuned balanced secondary. This secondary drives the crystal filter input circuit of the 455 kc IF strip. Coax cables are used to couple the two units.

Temperature runs were made on all of the coils in the signal path. The drift was low enough to not warrant temperature compensation.

Incorporated in the RF unit is a "Test Oscillator". It is possible with this oscillator to align the RF coils without the aid of a signal generator. The oscillator is a transitron providing two terminal operation. Thus it is possible to connect an RF coil to the oscillator without the need of a feedback winding. By using the BFO and the tuning dial the RF coils can be resonated at prescribed frequencies for alignment.

It was decided to use this oscillator for two reasons:

1. Signal generators are notoriously inaccurately calibrated in the very low frequency ranges. The manufacturers generally strive to provide accuracy in the more widely used ranges.
2. The very low Q coils used in the R-389 make accurate alignment tedious if not impossible. A small error in each coil may seriously impair the band pass of the front end.

Unfortunately this oscillator does not oscillate at the exact frequency of anti-resonance. This error is small, however, and consistent; and it is felt that the service advantages provided by the oscillator outweigh this disadvantage.

#### The Injection Path

As stated before the frequency accuracy and stability of the 10.455 kc crystal oscillator is unimportant because of the ring canceling action. A complete block diagram of the injection path is shown in Figure 2. It



## Courtesy of <http://BlackRadios.terryo.org>

will be noted that the oscillator feeds injection to the second mixer and push-pull injection to the injection mixers. This is accomplished by means of a transformer, the secondary being balanced. The injection mixers are balanced in such a manner as to cancel the 10,455 kc input. This is necessary due to the possibility of a spurious response at 455 kc if the 10,455 kc is permitted to reach the first mixer. The injection mixers are fed balanced input at the VFO fundamental or second harmonic from a phase inverter. The phase inverter is driven by the VFO buffer from a tuned plate load which is tuned either to the fundamental or second harmonic.

The injection mixer plate load is tuned and the two frequency ranges are covered by two coils. This plate load is coupled to a cathode follower amplifier called the input coupler. This input coupler drives an "m" derived, low pass filter at its characteristic impedance. The filter is designed to have maximum attenuation at 10,455 kc (50 db) and cutoff frequency is 10,000 kc. This is to further reduce the level of 10,455 kc reaching the first mixer, but must pass the injection range of 8495 kc to 9986 kc.

The filter output is coupled to a grounded grid amplifier called the output coupler. The output coupler plate circuit is tuned to the injection frequency as is the plate circuit of the injection mixers.

The output coupler plate circuit is coupled to a cathode follower called the mixer driver. The mixer driver has an untuned transformer in the cathode circuit and is used to drive the cathodes of the first mixer.

The first mixer is balanced. The balance circuit is such that the injection is canceled in the plate circuit. This is necessary to preserve the signal-to-noise ratio below 100 kc and is adjustable by means of a cathode balance potentiometer in the first mixer. As the input frequency lowers below 100 kc, the injection frequency approaches the 10 mc first IF frequency; the result of which is transmission of noise from the injection path into the signal path. Cancellation of the injection voltage minimizes this effect.

### The 28-Volt Power Supply

A dry disc rectifier, power transformer, and capacity filter comprise the 28-volt power supply. This supply furnishes power to the band-switching motor. The commutator circuit causes a tube to conduct which in turn energizes the relay controlling the power supply.

### 4.2.5.3 Mechanical Considerations

A complete report of the mechanical design is beyond the scope or intent of this report. However, several major points will be discussed.

Courtesy of <http://BlackRadios.terryo.org>

### The Oscillator Stop

Since the receiver was designed to cover its entire spectrum in two sweeps, it was necessary to provide considerable vernier action within the oscillator proper. Approximately 50 turns of the oscillator are required to cover its range. The usual tab washer stop would be too long for this many turns. A unique gear and pawl system is used to provide a secure stop. Further gear reduction of the oscillator gives a total of 208 turns required at the tuning knob to cover the range. This requires a stop of relatively high strength since the stop is located on the oscillator shaft. This stop is shown in Figure 45.

The Signal Corps was of the opinion that 208 turns required at the tuning knob was excessive for search operation or quick frequency change. Accordingly, we incorporated a motor tuning system to assist the operator. This is a clutch operated reversible system and will tune a complete range in less than one minute. This can be seen in Figure 13.

A cam driven slug rack system providing a travel of 1-1/4 inches would require excessive space. Reversible lead screws similar to those used in fishing reels, were used in place of cams. These proved to provide satisfactory linearity without special tooling for their manufacture. The lead screws are gear driven from a line shaft system. This technique has the advantage of operation in parallel rather than series and so does not build up large amounts of backlash.

Construction techniques were governed by the environmental requirements of the specification. Vibration and shake tests caused additional strengthening to be added in later models.

### 4.2.6 R-390 RF Circuits

The approximate size and shape of the R-390 RF unit had been determined by the early planning of the main frame and sub-units. The general frequency scheme had also been selected and the work of detail designing could be started on such things as the coils, crystal oscillators, and mixers. This work, along with the mechanical drives in these units, was the most complicated and took the longest time of anything in the project. The final RF unit is shown in Figures 35, 36 and 36A.

#### 4.2.6.1 General Design

The RF unit was designed to provide frequency coverage from .5 - 32 mc with good sensitivity, a minimum number of bad spurious responses, and high rejection to image and IF frequencies. The circuit is a triple superheterodyne below 8 mc, and double superheterodyne above 8 mc. This type of circuit was chosen for two basic reasons. In order to provide good stability and dial accuracy, the variable frequency oscillator must be a precision device, operating at a fairly low frequency and with a limited range (1 mc). Use of such a VFO requires the use of an extra conversion

## Courtesy of <http://BlackRadios.terryo.org>

stage to convert incoming signals to a frequency range which can be used in conjunction with the VFO to produce a 455 kc IF. In order to reduce image response to a satisfactory level at the highest ranges of the receiver this variable IF frequency should be between 2 and 3 mc. Using this type of dual conversion, some bad 3rd order spurious responses will be encountered between 4 and 6 mc, and 1st order spurious responses between 2 and 3 mc. This makes it necessary to go to triple conversion below 7 mc in order to avoid these bad spurious responses. By means of triple conversion it is possible to reduce all spurious responses to 5th order or higher.

Space limitations on the size of the RF chassis made it necessary to limit the number of RF coil ranges to six. Because of the multitude of tuned circuits, slug tuning is the most practical way of varying the frequency, since as many as 10 variable tuned circuits are in use at the same time. Figure 2 is a block diagram illustrating the operation of the RF unit.

### 4.2.6.2 Coil Design

#### Applicable Specification

Specifications applying most directly to coil design are:

- a. RF circuit bandwidth
- b. IF and image rejection ratio
- c. Service test effects on sensitivity
- d. Sensitivity
- e. Antenna input circuit

#### Design Consideration

It has already been mentioned that six RF coil ranges is the maximum number that could be accommodated on the RF chassis. As it turned out this is also the minimum number that could do the job. Using high grade iron cores, which are little affected by climatic changes, it is difficult to get more than 2-1 frequency coverage in any coil, particularly when the slug travel is also limited, as it is in the R-390 receiver. Figures 39 and 40 show constructional details of the RF coils.

#### Slug Tuning

Slug tuning has a number of theoretical advantages over capacitive tuning among which are these. By proper choice of iron, the bandwidth of any coil may be made nearly constant throughout its range. This condition also produces a constant impedance coil. For a frequency coverage of 2 to 1,

Courtesy of <http://BlackRadios.terryo.org>

the core should be so chosen as to reduce the  $Q$  2 to 1 as the slug varies from its position at the highest frequency to its position at the lowest frequency. Then  $BW_1 = \frac{f_1}{Q_1}$  represents the bandwidth at  $f_1$ , the low frequency end of the coil. The bandwidth at  $f_2$ , the high frequency end, is

$$BW_2 = \frac{f_2}{Q_2} = \frac{2f_1}{2Q_1} = BW_1.$$

If  $Q$  varied exactly as the inverse of  $f$ , the bandwidth would be constant throughout each coil range. This condition is only approximated in practice since the  $Q$  drops relatively too fast with frequency at first.

If  $Q$  varied exactly as the inverse of  $f$ , coil impedance would also be constant throughout the frequency range since  $Z_1 = Q_1 X_1$  where the subscript indicates the low frequency end of the coil range. Then  $Z_2 = Q_2 X_2$  but  $Q_2 = 2Q_1$  and  $X_2 = X_1/2$

$$\text{so: } Z_2 = \frac{2Q_1 X_1}{2} = Z_1$$

Again, since this condition is only approximated, the gain of the receiver is not absolutely constant throughout each coil range, but in general, varies between 1-1/2 and 2-1/2 to 1, depending on the coil range in use.

#### Number of RF Coils

The number of RF coils to be used in any one band was set at four, including the antenna coil. It was thought that this would provide adequate protection against IF and image frequencies. As it turned out it was impossible to get the required  $Q$  in the 16-32 band and consequently the image response occasionally drops below 80 db around 24 mc, where the bandwidth is the widest.

#### Type of Winding

Originally the coils were wound at a constant pitch, and the cams driving the slug rack were cut to give a constant frequency change with respect to angular rotation. One receiver was built using this principle, but the scheme was abandoned because in order to work right the mechanical position of the cam had to be perfect. If it were off ever so slightly the coil would not track. Electrical alignment of the coil is also very difficult with this scheme, and no simple alignment procedure could be found. Linear wound coils may have been practical if less coverage were required or more slug travel available.



## Courtesy of <http://BlackRadios.terryo.org>

All receivers since the first model use variable pitch coils in conjunction with linear rise cams. Because the cam has linear rise anywhere on its usable portion, exact cam positioning is not critical. Variable pitch coils also allow a simple alignment procedure. Coil inductance is adjusted near the low frequency end of the coil range, while coil capacitance is adjusted near the high end of the range.

Up to 4 mc it is necessary to use a multilayer coil to obtain the required inductance. These coils were originally designed using nine pi's equally spaced with different number of turns in each pi. This type of winding has two disadvantages. Because the coil consists of lumped sections, the tracking cannot be made absolutely linear, but instead the tracking curve is a wavy line varying plus or minus about the desired straight line. The second disadvantage lies in the difficulty of mass producing this type of winding. Each pi must be wound separately and spacing between pi's must be critically maintained.

Variable pitch progressive universal winding overcomes both of these difficulties. Because the coil is continuous instead of being a sum of discreet sections, tracking is improved, and the coil can be entirely machine wound. All future multilayer coils should be designed using VPPU windings.

### Coil Q

Coil Q was largely determined by the requirement of RF circuit bandwidth. Through the broadcast band where strong signals abound, this consideration was made secondary to cross-modulation protection. The RF bandwidth at 550 kc is 9 kc to the 3 db points and at 1.100 mc it is 10 kc to the 1 db points.

Above the broadcast band, RF selectivity adds only a fraction of a db attenuation within the IF passband, assuming the coils are tuned up properly.

In an attempt to raise the Q of the 16-32 band coil as high as possible, the RF coils were tapped, reducing the tube loading on the coil. Tapping also has other beneficial effects such as reducing stray inductance and capacitance which reduces the tuning range of the coil. In addition, lowering the load impedance in the RF tube plate circuit serves to improve stability which becomes more of a problem at high frequencies.

In general, the Q at the high end of the coil range is largely a function of wire size and design of the variable pitch winding. These have been optimized in the 16-32 mc band to provide the highest possible Q. At the low frequency end of the coil range the Q is primarily determined by the characteristics of the iron core. Much time was spent trying to find the best slug for a given frequency range. The three important factors in the choice of core material were Q, permeability

Courtesy of <http://BlackRadios.terryo.org>

and stability under climatic variations. Finally the core materials were reduced to 3 types manufactured by Stockpole Carbon Co.; namely, S-100A, S-62, and S-51. The S-100A is used in the 8-16 and 16-32 mc RF coils and in the 9-18 mc VIF. S-62 iron is used in the 3-2 VIF and 4-8 mc RF coils. S-51 iron is used in the .5-1, 1-2 and 2-4 mc RF coils.

Below is a table showing coil Q's at the high and low ends of each coil range.

TABLE VIII

RF Coils				VIF Coils	
f	Q	f	Q	f	Q
.5	33	4	44	2	75
1.0	54	8	74	3	75
1.0	28	8	53	9	53
2.0	54	10	98	18	98
2.0	25	16	47		
4.0	54	32	108		

Q tolerance can be about  $\pm 10\%$ . Effective operating Qs in the set are somewhat lower especially at the higher frequencies. The coil Q of the 9-18 mc IF coincides with the 8-16 mc RF coils, since they are identical. The Q of the 3-2 mc variable I-F was chosen to give high attenuation to the second crystal oscillator frequency while maintaining adequate bandwidths.

#### Coil Impedance

A nominal value of 20,000 ohms was chosen as a design figure for the RF coils. This gives reasonable values of inductance and capacitance throughout the whole frequency range of the receiver.

#### Tracking Tolerance

Electrical requirements on the RF coils necessitates a tracking tolerance within .4 db per coil. Additional mechanical tolerances raise this to a total of 1 db per coil. The coupled variable I-F stages broaden the tuning of these stages so that only a 1 db tolerance is necessary for the sum of all 3 VIF coils. Assuming any mistracking in the antenna coil is tuned out by the antenna trimmer, the total mistracking allowance is 3 db for the RF coils plus 1 db each for both of the variable IFs, or 5 db maximum.

#### 4.2.6.3 Antenna Input Circuit

Taking up first the consideration of sensitivity it is evident that the higher the antenna coil gain, the higher will be the receiver sensitivity. If sensitivity were the only consideration, it would be desirable to make the antenna coil gain as high as possible. Other problems such as receiver

Courtesy of <http://BlackRadios.terryo.org>

overload at high input levels and cross-modulation make it necessary to compromise. Then, also, at the high frequency range (16-32 mc) the impedance of the antenna coil is limited both by the inevitable stray capacitances and the RF losses of switches, tube sockets and input impedance of the first RF tube. Because of these stray losses and stray capacitances, the impedance across the antenna coil is on the order of 10,000 ohms above 16 mc and approximately 20,000 ohms below this frequency. With an input impedance of 125 ohms, this represents a coil gain of 4.5 and 6.3 respectively. Because of mismatching, these figures are seldom attained.

Antenna Coil Primary

In order to provide electrostatic shielding between primary and secondary, the primary is wound inside split brass rings mounted coaxially with the coil. Figure 39 shows the construction of the antenna coil. It was found by experiment that if all the turns were placed in a single ring, no position of the ring could be found which gave anywhere near constant impedance over the tuning range. Splitting up the winding into two rings suitably spaced provided a reasonable compromise between simplicity of construction and constancy of antenna input impedance. However, instead of 125 ohm  $\pm 15\%$  the impedance actually varies from 50 - 300 ohms. The widest variation occurs within the 16 - 32 mc band antenna coil. There are only three primary turns on this coil and positioning of the rings is quite critical. Despite the use of electrostatic shielding between primary and secondary, careful shielding underneath the RF chassis between primary and secondary coil terminals along with an antenna balancing trimmer, it has not been possible to obtain the 54 db balance to unbalance ratio required. The following table shows approximate balance to unbalanced ratios obtained:

<u>Band</u>	<u>Balance Ratio</u>
.5 - 1	45 db
1 - 4	40 db
4 - 8	35 db
8 - 16	30 db
16 - 32	25 db

Unbalanced Antenna Input

According to the specification, the unbalanced antenna input is to be used both for single ended whip antennas and doublet antennas using 50 ohm cable. In order to accomplish matching from a short whip to the antenna coil at low frequencies, loading coils are necessary to tune out the capacitive reactance of the whip. In order to be effective these loading coils must have low losses, and tuning becomes quite critical. Besides these

Courtesy of <http://BlackRadios.terryo.org>

problems the compactness of the RF unit left no room for such coils. Because of these factors it was decided not to attempt to match perfectly for whip antennas at low frequencies.

The other consideration in designing the unbalanced input system was the problem of providing reasonably good matching for low impedance resistive antennas (half-wave doublet, folded dipole, etc.). Over the range 1 - 16 mc this has been accomplished fairly well, with resistive inputs varying from 42 - 360 ohms in this region.

Both types of unbalanced input can be accommodated reasonably well with capacitor coupling. An antenna trimmer has been provided to tune out reactance reflected across the coil from either the balanced or the unbalanced input.

In summary, these are the considerations that governed the choice of unbalanced input coupling capacitors:

(a) Coupling capacitor shall be limited to such size as will permit complete trimming out of reflected reactance of any capacitive antenna.

(b) Within the limits set up above, the capacitors shall be chosen to provide a good match between the whip antenna and the antenna coil.

(c) These values of capacity should be modified slightly if necessary to provide good matching for low impedance resistive antennas.

(d) Two important exceptions are noted. These are:

(d1) Consideration (a) would lead to a capacitor in the .5 - 1 mc band considerably too small for consideration (b) and (c). Therefore, it was increased 33 per cent at a sacrifice of complete tuning out of resistance for low impedance capacitive or resistive antenna. Since such antennas are not often encountered in this frequency range, such a situation is not serious.

(d2) Stray capacitance limits the size of the 16-32 mc antenna coupling capacitor to 5 uuf. This value is too small to provide adequate coupling, and consequently sensitivity suffers slightly in this range.

#### Static Charge Drain Circuit

In accordance with the specification a static discharge circuit was incorporated consisting of a 220 k ohm resistor in parallel with a neon lamp between the unbalanced antenna terminal and ground. The resistor drains off charges which don't have enough voltage to fire the neon lamp, while the latter provides a rapid discharge for a suddenly applied high voltage.



## Courtesy of <http://BlackRadios.terryo.org>

### Circuit Diagram

A functional circuit diagram illustrating the antenna input circuit is shown on Figure 63. Note the capacitor in series with the ant trimmer capacitor. This is necessary with three of the coils to reduce the total capacity across the coil. Except on the 16-32 mc band it does not seriously affect the ant trimmer effectiveness. Although not shown on this simple circuit diagram, the coil preceding the one in use is shorted out to eliminate "suck outs" which would otherwise occur.

### 4.2.6.4 RF Stages

From the specifications, the three most important considerations in the design of the RF stages are noise contribution, gain, and strong signal handling capabilities.

### Noise Contribution of RF Stages

Once the gain of the antenna coil has been fixed, the next method of raising the sensitivity of the receiver is to use a low noise first RF tube. All low noise pentodes, however, are sharp cut-off tubes, and application of full AGC to these tubes results in severe distortion above about .1 volt antenna input. A one volt signal 30% modulated at the antenna has a possible peak voltage of 11.5 at the grid of the first RF tube with the antenna coils used. The first RF tube must be able to handle this voltage without serious distortion, and in order to prevent the grid from going positive with such a voltage, at least 11.5 V of bias must be supplied to the tube. For most sharp cut-off tubes, this lies far beyond cut-off, but the 6AJ5, though nominally a short cut-off tube can be operated so that it has fairly satisfactory remote cut-off characteristics. This is primarily due to the fact that it was designed for 28 V plate and screen operation. Application of screen voltage to this tube through a large screen dropping resistor provides proper operation when used with a 180 V B+ supply. When AGC is applied to the control grid, the screen voltage rises, thus preventing an early cut-off and giving a much better remote characteristic than any other sharp cut-off tube tried.

As an example of its superiority, here is a comparison between it and the 6AK5:

Distortion at .7 V input (30% mod.)

6AK5	16%
6AJ5	3%

Audio rise from 10 uv to .7 V (db)

6AK5	18.5 db
6AJ5	10.0 db

Courtesy of <http://BlackRadios.terryo.org>

Despite the use of this tube, sensitivity at times rises above 3 uv, due to variations in tubes, ant coil gain, etc. It is proposed, therefore, to raise allowable AM sensitivity to 3.3 uv below 14 mc and 4.4 uv above 14 mc. Allowable CW sensitivity is to be raised to 1.3 uv above 14 mc.

The cascode amplifier was also tried on breadboard models and seemed to offer some improvement over pentodes in regard to sensitivity, but again, their poor performance when AGC is applied disqualifies them. They are often used in TV sets with AGC applied, but they will not handle signal levels of 12 V peak as required in this receiver.

### Gain

Closely allied with a low noise first RF tube in the matter of noise contribution is the gain provided in the first RF stages. For greatest sensitivity the first RF stage should have a high gain, but such high gain is undesirable from other standpoints. The signal handling capability of the second RF tube does not greatly exceed that of the first RF tube. This means that the gain of the first RF tube should be limited to unity when a 1 V signal is applied to the antenna. If the AGC voltage reduces the first RF tube gain by 10 with 1 V of antenna input, then the maximum upper limit of gain below AGC threshold is also 10. In order to hold down cross-modulation and reduce the magnitude of spurious responses, low gain is also desirable. From these considerations a nominal gain of five was chosen for the first RF stage. With this value of gain, the noise contribution of the second RF stage is not very great and it becomes possible to choose the tube type on the basis of other considerations. These considerations are distortion at high inputs, freedom from cross-modulation and good AGC characteristics. A remote cut-off pentode is desirable from all these standpoints and consequently a 6BJ6 was chosen for the second RF stage.

It was stated above that spurious response was affected by gain. Best signal-to-spurious ratio is obtained if signal level at mixer grids is held low. On the other hand best sensitivity results with high RF gains. A compromise was reached at a gain of 25 from antenna to first mixer grid. This allows a gain of approximately one in the second RF stage. With the same overall gain of 25 to the first mixer grid, dividing the gain in the RF stages into five for the first RF and one for the second gives better sensitivity than any combination using a gain larger than unity in the second RF stage. Considering the noise produced at the mixer grid by the first and second RF stages, a constant gain from first RF grid to first mixer grid results in a fixed noise contribution from the first RF tube irregardless of the division of gain between first and second RF tubes. The noise contribution of the second RF stage to the total noise at the mixer grid is the second RF stage noise multiplied by the gain between second RF grid and first mixer grid. Obviously the smaller this gain the less noise contribution by the second RF stage.

## Courtesy of <http://BlackRadios.terryo.org>

### Strong Signal Handling Capability

Some of the items planned for discussion under this heading have already been taken up. These include the superiority of the 6AJ5 over other sharp cut-off tubes with respect to AGC control and strong signal distortion, and the choice of the 6BJ6 as the second RF amplifier from the standpoint of better AGC characteristic, lower distortion, and better cross-modulation characteristics. It would be well to note here that the 6AJ5 is also very good in regard to cross-modulation for interfering signals up to .1 volt. At higher signal levels it deteriorates below the performance of remote cut-off tubes, particularly at levels around 1 volt.

It may be noted that AGC is supplied to the RF tube grids through high values of resistors. These help to prevent blocking of the receiver by strong signals outside the IF pass band, but within the RF pass band. These strong off-tune signals may cause the first or second RF tubes to draw grid current which will back up into the AGC line. By placing high resistors in series with the grids, little of the grid leak bias so developed is fed back to the IF controlled tubes.

Tests on the strong signal handling capability of the receiver reveal that with AGC on and RF gain wide open, the blocking level always exceeds 1 volt.

#### 4.2.6.5 Mixers

##### General Considerations

The over-riding consideration in the choice of mixer tubes was rejection to spurious responses. The problem resolved itself simply into this: with RF gain adjusted as necessary for a given sensitivity, which mixer tube gives the best rejection to spurious responses? Considerable experimentation was done on mixers from which the following conclusions were drawn: All mixers are very level conscious in regard to production of spurious responses. In order to get measurements that can be duplicated, the reference input was standardized at 5 uv by agreement with the Signal Corps. For the same input level at the grid of the mixer tube, pentagrid mixers are superior to triodes and pentodes. However, the requirement for the same signal-to-noise ratio irregardless of the mixer type required that greater RF gain be used in conjunction with pentagrid converters. When the RF gain was adjusted for each tube type to give the same signal-to-noise ratio, triodes actually gave the best rejection to spurious responses. Among different types of triodes, there are variations, and the 6C4 was found to be the best of all tubes tried. This is based on an average since there is considerable variation among tubes of the same type. For every tube tried, bias and oscillator drive were adjusted for optimum spurious rejection. Careful adjustment of the bias and/or oscillator drive could reduce a spurious down 20 db or more below normal level. Another tube of the same type would require a slight readjustment to obtain the same results. Then too, this particular adjustment of the bias

Courtesy of <http://BlackRadios.terryo.org>

would have no effect on a spurious of different order which would require an entirely new readjustment. The most that could be done was to find a bias, which, aside from these unusual "holes" gave the best spurious rejection for all orders of spurious responses likely to give trouble.

Many different schemes of balanced mixers yielding useful output were tried, but they offered no significant improvement over single ended types. It is possible that this may have been largely due to unbalance between the two mixer tube sections, and also to the difficulty of obtaining circuit balance at the frequencies involved.

#### Oscillator Coupling

Many methods of coupling oscillator and signal voltage into the mixer exist, but the following are the considerations which led to cathode injection:

One side of the signal source is normally grounded. Unless parallel grid injection was used, the oscillators would have to be fed in series with the signal on the grid side. Parallel injection involves a loss of signal or oscillator voltage, or both. Series injection on the grid side involves keeping both oscillator leads above ground, and with little capacitance to ground in order not to detune the signal coil.

Coupling the oscillator into the cathode removes the above objections. There is some coupling of the oscillator voltage to the grid due to grid cathode capacitance with this scheme, but it never exceeds 15 per cent and causes no difficulty.

#### High Variable IF

The high variable IF frequency range was determined by several considerations.

#### Oscillator Crossovers

In order to eliminate crossovers of the type  $lnX_1 - mX_2 = VIF$ , the highest common factor of  $X_1 \times X_2$  must be no lower than four except in the .5 - 1 mc band where it may be three. In this equation  $X_1$  and  $X_2$  are respectively the frequencies of the first and second crystal oscillators.  $M$  and  $n$  are any two integers required to satisfy the equation. The VIF of the equation is the 3-2 VIF. If  $X_1$  and  $X_2$  have a highest common factor no less than four, it is impossible to find any integers  $m$  and  $n$  which will satisfy this equation, and there will be no spurious signals generated by harmonics of one oscillator beating with harmonics of the other oscillator. In the .5 - 1 mc band the VIF varies from 2.5 - 2 mc. This allows the highest common factor to drop down to 3, which with the 3 - 2 VIF also is the highest possible common factor.



## Courtesy of <http://BlackRadios.terryo.org>

An exception was made on band 3 in order to sidestep a 4th order spurious.  $X_1$  and  $X_2$  were chosen so that  $n = 10$  and  $m = 20$  before a difference of their harmonics lies in the 3 - 2 VIF. These are high enough so that no trouble is caused.

### Spurious Crossovers

The high IF should be chosen so that no spurious crossover lower than 5th order exists.

### Frequency Range

All high IF frequencies must be within a two to one frequency range to permit tuning with a single coil.

### Number of Coils

Although the frequency scheme was chosen to eliminate whistles caused by crystal oscillator harmonics, the crystal oscillators can, if they get into the wrong mixers, cause spurious responses. Three high VIF coils were chosen as the minimum number required to provide adequate protection of the second mixer from first crystal oscillator voltage fed into it via the high VIF. Three coils provided a mixer gain of slightly greater than one which is adequate.

### 3-2 mc VIF

The 3-2 VIF design was determined by the following considerations:

Image Rejection - The frequency should be high enough to provide adequate image rejection in the highest frequency band.

Stability - In order to get good receiver stability the VFO must operate at a fairly low frequency. The VIF must then be 455 kc away from this VFO frequency.

Number of Coils - Again three coils were chosen both to provide adequate attenuation to the second crystal oscillator frequency and to provide additional selectivity for the last mixer at high frequencies. Despite the high Q of these coils, they contribute little attenuation within the passband of the 16 kc IF bandwidth position. The circuit was designed to approximate the maximally flat case. The bandwidth to the -.5 db points is 27 kc at 2.1 mc and about 50 kc at 3 mc. Gain in this mixer stage is normally 2.

### 455 KC IF

The 455 kc IF coil in the plate of the last mixer was designed to give the maximum possible gain consistent with the desired bandwidth and output impedance. Gain of the last mixer stage is nominally 1.7.

### Spurious Rejection

Despite all the experimentation undertaken on mixers and frequency schemes, no means was found to reduce spurious responses to the low level demanded by the specification. However, all spurious responses have been reduced to 55 db or better.

#### 4.2.6.6 Miscellaneous Considerations

##### Parasitic Suppressors

Under certain conditions, parasitic oscillations have been discovered in the second RF tube, first, and second mixers. These were caused mainly by long grid and plate leads, the tube acting as a tuned-plate tuned-grid oscillator at frequencies in the hundreds of megacycles. Placing a 27 ohm resistor in series with the grids lowered the Q of the grid line low enough to prevent oscillations.

##### Test Points

As an aid in troubleshooting and to facilitate gain measurements in the RF, test points are provided leading to each tube's control grid. This is a decided help since the underside of the RF unit is not readily accessible.

##### Lead Filtering

Each RF and mixer stage is decoupled from B+ by means of a 2200 ohm resistor and an .01 uf capacitor, except for the first RF tube which had its plate decoupled with a 1 uf capacitor. The purpose of the capacitor is to prevent audio frequencies on the B+ line from remodulating the RF signal. Initially when the set was tuned to the side of a strong carrier, it broke into an audio oscillation. A small disturbance on the B+ line would modulate the B+ line creating sidebands within the passband of the receiver. Detection of the composite signal feeds audio voltage back to the B+ line where it remodulates the RF tube and maintains the audio oscillation. All mixer tube filaments are thoroughly filtered to prevent the oscillators from getting into wrong mixers and causing spurious responses.

##### RF Gain Control

Manual RF gain control is obtained by varying the cathod resistors of the RF amplifiers and two of the IF amplifiers. The RF gain control is bypassed with a 50 uf electrolytic capacitor to reduce noise induced by rotation of the control.

#### 4.2.6.7 The Crystal Oscillator Unit

The crystal oscillator unit is shown in Figures 41 and 42. This unit could have been part of the RF unit but was made a separate unit to allow easier manufacture and maintenance.

## Courtesy of <http://BlackRadios.terryo.org>

### General Design

The basic oscillator circuit used is the pentode cathode-feedback Pierce oscillator. Since the screen is grounded, the plate is fairly well shielded from the input and tuning the plate circuit has negligible effect on oscillator frequency. The plate tank is tuned to either the fundamental, second harmonic or third harmonic of the crystal as the RF unit requires. This is necessary since JAN specs allow no CR-36U crystals higher than 15 mc while the RF unit requires frequencies up to 34 mc. Overtone crystal oscillators using the series resonant frequency of the crystal were not considered because of their poor stability and low output voltage.

Figure 64 shows the schematic of the second crystal oscillator in the band 3<sup>4</sup> switch position. Although there are 32 bands, only 18 crystals are used in the second oscillator since some are used more than once. Also there are only 25 output frequencies tuned with 24 trimmers since bands 0 through 7, with the exception of band 3, use frequencies which are used on some of the other 24 bands. Band 3 requires an output frequency of 18.6 mc, which is obtained by using the tuned circuit for 18 mc as used on bands 6 and 15 with a series capacitor switched in on band 3 to raise the resonant frequency to 18.6 mc.

The first crystal oscillator, operating only on bands 0 to 7, uses five crystals, three of which are used twice, and five trimmers to tune them. This oscillator operates only on fundamental frequencies of the crystals.

### Choice of Tubes

After experimentation with a number of different pentodes, the 6AJ5 was found to give the required output voltage with the least power drain.

### Plate transformers

In the plate of each oscillator tube, is a transformer for peaking the output at the desired frequency and supplying voltage at low impedance to the mixer cathodes. Because of the very wide range it covers and because at various times it is tuned to fundamental second or third harmonic of the crystal, the output of the second oscillator varies 3 to 1 in voltage over its frequency range. Since the second mixer is fairly well saturated, the receiver gain varies only about half this amount. Because of its much narrower frequency range the first crystal oscillator output voltage varies about half this amount. One of these transformers is shown in Figure 65.

### Oscillator Ovens

Measurements indicate that the chassis of the R-390 receiver rises about 20 deg C above the ambient temperature under continuous operation. Since the receiver is to operate in ambient temperatures up to 65 deg C, an oven temperature of 85 deg C is necessary to insure that oven control is effective up to this temperature. CR-36/U crystals designed for this operating temperature have been used for the crystal oscillator. The construction of the oven can be seen in Figure 42. It is made up of an inner and outer metal box with a 50 watt heating element wound directly on the inner one. An 85 deg C thermostat is also mounted directly on the inner box with about 3/8 inch of fiberglass insulation between boxes. The inner box is made of heavy brass to give good (head) distribution and thermal inertia. With this oven the crystal temperatures are held to less than two degrees temperature variation.

### Lead Filtering

A number of spurious responses in the receiver are caused by oscillators getting into the wrong mixers. In order to reduce leakage from one crystal oscillator to another, careful shielding is employed between oscillator sections and common B+ and filament leads are well filtered.

#### 4.2.7 R-389 Variable Frequency Oscillator

The design of this unit was started as soon as the frequency range and tuning speed were set. The basic physical design was to be based on a standard oscillator with a temperature controlling oven added. However, several factors came up which made a special design necessary. The final oscillator is shown in Figures 47 and 48.

##### 4.2.7.1 Design Problems and Solutions

The frequency change per turn of 10 kilocycles made it necessary to use an extremely fine pitch leadscrew. This leadscrew was established at 40 pitch. Because of the very high tuning ratio of the V.F.O. (2.09 to 1) a ferrite core was necessary. Many problems have been solved in pushing the state of the ferrite art to the present point.

### Ferrite Development

The high permeability of ferrite was the outstanding reason for its usage. At the time of the choice the temperature coefficient of the available ferrite was quite bad. As work proceeded a method was worked out to partially compensate the poor T.C. This method involved use of differential expansion properties of materials. This device was no more than developed when a new shipment of ferrite was received that was of opposite T.C. polarity. Since this indicated it was possible to cross over a zero T.C. reference, serious work then began to secure a product with nearly zero T.C. It was also recognized that the device that had been invented would not perform satisfactorily if the TC changed polarity.



## Courtesy of <http://BlackRadios.terryo.org>

Since initiation of development of low TC cores began, Collins has successfully fired to correct TC a number of cores thus leading the way for ferrite manufacturers to establish the proper production techniques. At the time of writing, three manufacturers have produced cores in small quantities and they are working actively toward production of quantity output.

### Corrector Development

The variable frequency oscillators use a mechanical corrector as a basis for establishment of extremely linear calibration. The usage of a 40 threads per inch leadscrew made impossible the use of a standard corrector. A new radial type corrector was developed that would accurately allow differential movement of the core amounting to approximately 115 degrees rotation. This is sufficient for correcting the error produced by coil winding procedures and core nonhomogeneity.

A large amount of experimenting and design was required on this item to enable a proper dynamic operation.

### Oven Development

The specifications for the stability of the overall equipment made the use of an oven necessary. Also the size limitations of the parent equipment made it necessary that the oven diameter not exceed 3-1/2 inches. The projected equipment warmup temperature made it necessary to plan an oven operating temperature of 75 to 80 degrees Centigrade. The requirements of oscillator warmup required that the units be stabilized within 15 minutes.

With these design parameters in effect, work progressed and a preliminary model was built. This model had a fast and slow heater with separate thermostats. The intent of the fast heater was to cause a rapid warmup of the frequency determining elements of the oscillator. Tests soon indicated that no matter how fast the outer heater warmed up it took about the same amount of time for the oscillator to stabilize. Too rapid heating caused overshoot with delay in stabilization.

The final design selected used a single speed heater which caused some initial overshoot but amounted to approximately critical damping of the warmup curve.

Using this oven on the oscillator the maximum frequency deviation during warmup occurs at an elapsed time of 15 minutes. After 30 minutes the frequency is nearly stabilized and after an hour frequency drift is within about 25 cycles of ultimate stabilized value.

Cycling of the thermostat initially caused some frequency cycling due to oven current variation. It was necessary to build the heater element onto a mu metal cover. This succeeded in reducing the oven cycling to less than 5 cycles.

Courtesy of <http://BlackRadios.terryo.org>

The final oven is a 26.5 volt unit and requires 60 watts power when operating.

A bifilar winding is used to avoid reactive effects and transient magnetic fields.

#### Coil Design

Coil design, of course, depends upon the core and the component physical configurations in the coil vicinity. Since the core problem has been such a lengthy one, several coils have been designed each for different cores. Each time the core permeability is increased an improvement in length of linear section is made so that it is now believed possible to finish the design with a calibration error not exceeding  $\pm 50$  cycles over almost all of the tuning range. It does not seem possible to make calibration better than  $\pm 100$  cycles from approximately 950 kc to 980 kc.

During the design of this coil the use of an inductive trimmer was attempted. Since all the tuning ratio that could be mustered was needed, a capacitive trimmer was substituted. This trimmer is a variable air type MAPC with maximum capacity of 100 mmf.

#### Mechanical Design

The basic mechanical design of this oscillator is comparative to others in Collins line of permeability tuned oscillators. Figures 45 and 46 show the outside oven and also the inside with shield and oven pulled back. The leadscrew is loaded to the main frame, or head casting by means of a high pressure spring through ball bearings. To the stabilized leadscrew, then, is added a precision threaded tuning core which, too, is loaded to the leadscrew. For maximum reset accuracy and stability, a rear bearing at the far extreme of the oscillator supports the leadscrew. In this oscillator it was necessary to use a ball bearing to eliminate radial motion.

The coil and capacitor are also mounted to the head casting for maximum rigidity and short leads. Insulated and sealed feedthroughs transfer energy from the tuned circuit outward through the head to the amplifier portion of the circuit.

The inner portion of the circuit, which contains the tuned circuit, is sealed from atmosphere by means of O-ring seals. There are three O-ring seals. The rotary shaft, the outer cover, and the trimmer cover cap are sealed in this manner.

It was found necessary to insert a 3/8 thickness phenolic plate between the head and the tube chassis to reduce the heat leakage. This heat leakage caused a severely slow warmup characteristic before correction. To insure mechanical security, the tube chassis is fastened to the phenolic shield, the shield is fastened to the head and the chassis is then fastened to the head. This completed unit has withstood severe vibration tests with no sign of breakage or loosening.

## Courtesy of <http://BlackRadios.terryo.org>

The phenolic plate is used for mounting the outer oven cover, which cover ties to the parent equipment at the rear. To avoid thread stripping or the breaking out of these radial screws, the tapped holes in the phenolic plate are lined with a Helicoil insert. This insert serves to strengthen the threads and lock the screws into place.

The covers are concentric with each other. The sealed cover is innermost, the heater shell close spaced to it, and the outer cover separated from the heater shall by approximately 1/4 inch radial dimension. This space is filled with fiberglass batting for thermal insulation. See the photograph for details of construction.

### Circuit Development

The circuit is a single tube electron-coupled oscillator of the three terminal type. See schematic diagram for details. The output from the plate of the oscillator tube is fed to the buffer tube grid. The buffer is especially designed to accentuate the second harmonic. Measurements show the second harmonic content to be equal to the fundamental when connected to the parent equipment load circuit. This was done to provide equal drive to the mixer for fundamental and second harmonic injection. A 5749 (6BA6W) is used for the oscillator and a 6BH6 is used for the buffer.

Considerable component value adjustment was necessary to accomplish good voltage stability over the 2.09 to 1 tuning range.

A special fixed capacitance tank capacitor was developed for the application. The stability of this component is as good as the state of the art allows for temperature coefficient and capacitance drift.

### 4.2.7.2 Performance

It should be noted that the performance figures are based upon extensive testing of engineering models plus tests of a production nature on preproduction models. Also, the final production core is not yet available at the date of writing. Final performance figures could not be given in this report and will not be available until the production core is used and an oscillator is completely tested therewith.

### Frequency Drift with Temperature, Oven On

Maximum frequency change from room temperature to minus 40°C was measured at minus 66 cycles. Frequency change from room temperature to plus 85°C was a maximum of plus 32 cycles. The frequency temperature measurements were made at both ends of the tuning range.

Courtesy of <http://BlackRadios.terryo.org>Frequency Drift with Temperature, Oven Off

The data obtained for these measurements are completely dependent upon the core used. Some cores have given frequency deviations from room temperature up to 90°C of less than 300 cycles. All units built to date have shown a large deviation at low temperatures. Some of these deviations have been as large as 2000 cycles at the low frequency endpoint. It is believed that when final cores are received this situation will be much improved since linearity of the core temperature coefficient has improved with development. It is to be recommended that for maximum stability the oven should be used.

Voltage Stability

Circuit operating points have been adjusted to provide the best possible frequency stability with filament voltage change. B+ voltage coefficients have been sacrificed slightly to do this. The reason for this comes from the fact that filament supply regulation is not as good as is the B+. It was possible also to design so that as the tube ages the voltage coefficients age toward better operation and greater stability.

The B+ voltage coefficient at the 470 kc endpoint usually measures about negative 75 cycles for a 20% change. The filament coefficient measures about positive 15 cycles at both end frequencies for a 20% change of voltage.

Calibration Accuracy

The coil will have to be slightly redesigned for the final core, but based upon the latest core and coil design a calibration accuracy of  $\pm 50$  cycles should be possible from 469 kc to 950 kc. From 950 to 980 kc it is believed that  $\pm 100$  cycles will be the best possible accuracy.

Twenty Hour Stability

Various measurements have shown that with oven operating, after 90 minutes warmup, the frequency can be expected to stay within 25 cycles for the period.

The stability during this twenty hour period does depend somewhat upon the past history of the unit. If the oscillator has been inoperative for a period of a few days or more just previous to this test, a larger drift will be measured.

4.2.8 R-390 Variable Frequency Oscillator

The VFO for the R-390 was to have 10 turns and cover the frequency range 2.455 to 3.455 mc. This allowed the VFO used in the R-388/URR (51J-3) to be used as a prototype of this unit. The tuning range had to be modified slightly, the circuit of the prototype was not suitable, the stability requirements of the new unit required an oven, and to make the greatest improvement in stability component research and development needed to be done.



## Courtesy of <http://BlackRadios.terryo.org>

### Oven Development

The fundamental investigation of oven design was cooperative between this oscillator and the 70H-1. It was, however, necessary to modify the type of thermostat used on the 70H-2. The basic frequency is about four times higher on this unit and it also has a smaller total thermal mass so a thermal cycling was produced that was of too great a magnitude. The heater element was redesigned to increase its thermal mass and to accommodate a Fenwal themoswitch which integrates the temperature nearly the full length of the heater assembly.

This modification reduced the cycling to an amount less than 5 cycles deviation.

### Circuit Design

A rather lengthy program of research and development was embarked upon to determine the best circuit and tube for the application. A ruggedized tube was considered desirable. Several types of vacuum tubes were tested for aging of voltage coefficients, microphonics, and circuit operation. The final tube selected was the 5749 (6BA6W).

The outcome of the circuit development program was the three terminal electron coupled cathode feedback type. This circuit was found best suited for permeability tuning and is not dependent upon cumbersome reactive elements apart from the tuned circuit itself. This type of circuit also has the proper number of components for critical adjustment of tube operation without a redundancy which can cause additional frequency errors due to component aging. See the schematic diagram for complete circuit.

### Component Research

In order to achieve maximum stability of the oscillator for long periods it was necessary to thoroughly investigate powdered iron core aging, tank capacitor stability, lubrication, and seals.

### Powdered Iron Core

The powdered iron core aging problem was attacked in two different ways. First, the intrusion of moisture and vapor into the core was reduced by impregnation with a resin. Tests were made which show the permeability aging to be about 8 to 10 times slower and less than that measured upon an untreated core. Continuous research is being carried along presently to find materials and techniques that will still further improve the quality.

The second step taken was to approach manufacturers of the cores with the problem of aging. Considerable work was done with Radio Cores Company who have been trying various insulator materials and have been sending cores to us for aging test. The magnitude of this problem has been so great that an answer has not been found, although trends have been established for further research.

### Frequency Drift with Temperature, Oven On

The frequency of the oscillator will stay within 100 cycles, of the value measured at room temperature, from minus 40°C to +70°C. The oscillator oven must be shielded from direct air flow at the cold temperatures or else the oven temperature will not hold.

The frequency error becomes quite a little larger than 100 cycles when the oscillator temperature goes above 70°C since the oven temperature no longer holds constant and the temperature compensation of the oscillator is not flat above 70°C. Normal values of frequency change from 70 to 90°C are in the order of 500 cycles.

### Frequency Drift with Temperature, Oven Off

The nominal oscillator temperature compensation is being set up so that the maximum flatness of frequency versus temperature occurs near 60°C. Of course, there is a tolerance which cannot be avoided. This tolerance stems from the smallest value of compensation capacitor increment. Figure 68 shows the tolerance and its limits.

There is some additional frequency-temperature error caused by the powdered iron core temperature coefficient. This error is nominally small and at endpoint frequencies should not cause errors in excess of 150 cycles from that shown in Figure 68.

The temperature-frequency error at temperatures below 30°C is dependent upon capacitor temperature coefficient linearity plus initial compensation. The total amount of this error is not in excess of 800 PPM within the oscillator range and over the temperature range from 30°C to -40°C.

### Voltage Stability

Circuit operating points have been adjusted to provide the best possible compromise of plate and filament voltage-frequency characteristics. There has been allowance for tube aging so that the stability will slightly improve for the first few hundred hours of operation before becoming degraded by aged tube characteristics.

The plate voltage coefficient for a 20% change is under 100 cycles and the filament coefficient is under 30 cycles for a 20% change.

### Calibration Accuracy

The production oscillators will be calibrated so that the linearity will from any calibrated point in the tuning range to any other shall not exceed 750 cycles. Calibration accuracy when adjusted to zero error at the adjacent 100 kc/sec check point will not exceed 250 cycles exclusive of dial error. Resetting the oscillator from either direction of rotation to a given point will not exceed 35 cycles exclusive of dial error.

Courtesy of <http://BlackRadios.terryo.org>Twenty Hour Stability

After 90 minutes the oscillator has demonstrated the ability to remain within 100 cycles for 20 hours. This ability has been found to depend somewhat upon the recent history of the oscillator and upon the use of the oven.

If, for example, the oscillator has been unused for several days previous to the 20 hour stability a slow positive frequency drift may be experienced during the period. However, when in regular usage the stability will remain good for extremely long periods.

4.2.9 R-389 - R-390 Beat Frequency Oscillator

This BFO is actually part of the IF unit but is handled separately since it is a separate unit with special design problems.

4.2.9.1 Design Problems and Solutions

The problem was to design a sealed, narrow tuning range, highly stable oscillator in a small space. It was found that there was not room for an oven for this unit and since an external BFO could be substituted in the event extreme stability was necessary this was considered acceptable.

Electrical Components

The use of a small permeability tuned coil in series with a stable high Q toroid was decided for the coils. The capacitor was developed for the job by modifying the type of construction of a button silver mica.

The toroid and variable inductor relative size determination was readily accomplished as soon as a special powdered iron core was available. The toroid core material was selected after a rather lengthy selection of sizes, molding pressures, and powdered iron materials. The final selection leaned heavily toward Q and temperature coefficient as primary qualities.

The main capacitor requirements were such that necessitated the use of a potted ceramic type much as that used in the variable frequency oscillators. The capacitance, however, could not be placed in a ceramic unit as small as needed. Consultation and experimentation with button mica manufacturers indicated that by hermetic sealing, preaging, and by using specially selected mica the capacitor could be made satisfactory for requirement.

Mechanical

The small size necessitated use of an arrangement that allowed the tuning shaft to move axially 1/16 inch when tuning the required amount. The total axial movement allows for trimming the oscillator into its proper frequency region during production and assembly.

## Courtesy of <http://BlackRadios.terryo.org>

The mechanical components consist of a head with pressed in sleeve bearing, a concentric tuning shaft to which is welded the screw of the powdered iron tuning core. A lead nut and load nut with the required loading spring are together on the screw of the iron core and are assembled to the coil and to a threaded part of the head which is concentric to the front bearing. Standoffs from the head hold a rear plate to which is fastened the toroid coil and the capacitor. Wiring is done after assembly and output connects to three sealed insulating feedthrough terminals which pass through and are soldered into the head. Figure 30 shows the final BFO with shield removed.

### 4.2.9.2 Circuit Development

While the actual oscillator amplifier circuit is not an integral part of the BFO, the circuit was developed for the best operation and voltage coefficient. The circuit consists of a 6BA6W tube and is a cathode tap-feed back type similar to that used in the other oscillator types. See Schematic Diagram for details.

### Frequency Drift with Temperature

The oscillator can be compensated so that from 25°C to 70°C the frequency will not deviate more than 75 cycles. This compensation is good for a wide range of temperatures. The oscillator will normally deviate less than 200 cycles over the entire range of -40°C to +70°C. From +70°C to +90°C the drift becomes larger per degree and is not as predictable as for lower temperatures. Values of drift here range in the amount of -125 cycles.

### Voltage Stability

Maximum voltage coefficient for the oscillator when plate voltage is varied 20% is 10 cycles. A filament voltage change of 20% will cause 5 cycles change.

### Calibration

While no calibration correction is made the oscillators are to be production checked to insure a balance in tuning from center frequency that is within 500 cycles.

### 4.2.10 Crystal Calibrator

In order to meet the dial calibration accuracy requirements in the R-390 Receiver a Crystal Calibrator was required. It was determined that 100 kc calibration points were most desirable since this would give 10 check points across each one megacycle band and also be the best compromise between high accuracy and straight forward circuits.



The first problem of such a crystal calibrator was the crystal itself which had to be very accurate and stable since it was to be used as a frequency standard. No suitable 100 kc crystals were available and so the standard type of oscillator-multiplier circuit could not be used. Suitable crystals were available, however, at higher frequencies, so a one megacycle crystal with a 10:1 divider circuit was used. The schematic of the final circuit is shown in R-390 Schematic and the unit itself is shown in Figures 43 and 44. The crystal is a CR/36 and is mounted in a 26 volt oven which is always in use. The crystal is used in a triode oscillator circuit and has a variable capacitor across it to set it to exact frequency. The 10:1 divider is of the flip-flop type and uses a twin triode. This drives a distorter-buffer which feeds into the antenna circuit of the receiver giving good signals up to 30 mc. The divider has a variable capacitor that is used to set its "free-running" frequency slightly below 100 kc so that it will be triggered by every 10th cycle of the one megacycle crystal which is coupled into the multivibrators plate circuit. Several models of a calibrator were tried using variable drive level to the multivibrator as a means of locking it to the correct frequency, but the variable time-constant worked better in locking the multivibrator to the correct division frequency.

Some trouble has been reported by the Signal Corps in the calibrators operation, but no definite trouble could be found. Very careful analysis was made of each component in the entire circuit and no possible cause of poor operation was determined. The effect of "tube poisoning" or interface trouble was suspected since the calibrator tubes would be used only intermittently, but this was not shown definitely. Since it seemed to be more of an aging problem, more information might be available later on.

The oven used for this calibrator crystal is of a standard type made by Bliley Corporation with fiber glass insulation instead of the usual cork. The temperature is nominally 85°C and seems to hold quite close since the cycling in frequency is only about one ppm. The variable capacitor across the crystal, is adequate to set exactly on frequency any crystal meeting the Mil specification, and will pull a crystal about 30 ppm. The output which feeds into the receiver is coupled into the ground of the first RF tube through a 1 mmf capacitor and provides signals of 20 to 1000 microvolts throughout the range .5 to 32 mc. Equalizing has been done in this output circuit to make this range fairly constant, although some improvement might be made. The external antenna is shorted by the antenna relay during the calibration process so as to reduce the problem of noise and extraneous signals.

In order that dial read correctly when used with the calibrator, a mechanical system was devised to allow the frequency counter to be moved about 10 kc. This was done by means of a friction clutch in the counter drive and a screw knob, which releases the clutch and holds the counter while the rest of the receiver is tuned to the exact frequency. Then the clutch is released and the dial calibrated. This calibration process should be used whenever maximum accuracy is required, and will allow frequencies to be read and set to about 200 cycles. However, under normal operation without calibration, the receiver will still give accuracies of about 3 kc at all frequencies.

Courtesy of <http://BlackRadios.terryo.org>

In the early part of this program a calibration system was planned for the R-389 receiver. However, after considerable work, and after the frequency system was determined, a calibrator seemed impractical. The main reason was that to be of much use, 10 kc calibration points would be necessary, especially on the lower bands. This would require a rather complicated system and was not considered worthwhile. It was also planned that the variable oscillator used in the R-389 tuning system would be more accurate than the R-390 and should give good dial accuracy without check points. The R-389 oscillator finally developed did work out fairly well, and can give accuracy of  $\pm 100$  cycles on the low range and  $\pm 200$  cycles on the high bands. These figures were satisfactory for the Signal Corps requirements.

#### 4.2.11 Miscellaneous Circuits

This section covers the general design of several circuits common to both receivers and which had special design problems and solutions.

##### 4.2.11.1 Automatic Gain Control

In the original design, AGC was applied to the two RF stages and to the first two IF stages. Operating conditions for the tubes were adjusted so that it was nearly possible to hold audio output within 6 db from 5 uv to 1 v. It was later decided to change AGC control from the second to the next to the last IF stage in order to reduce noise on strong signals. Still later the first RF stage was changed from a 6BJ6 to a 6AJ5. Both of these changes resulted in a loss of control at inputs greater than .1 volt. Nothing was done at the time to relieve the situation since more pressing problems were at hand. Since then AGC has been experimentally applied to the second IF stages with a resulting 3 db improvement at 1 v input, but since the IF design was frozen, no further investigation was made and the change was not incorporated into the final design. No AGC is used on the mixers, since their bias has been adjusted for best spurious rejection and increasing this bias deteriorates the signal/spurious ratio. A functional schematic showing the operation of the AGC producing circuit in the fast position is shown in Figure 66.

##### AGC Amplifier

In order to prevent BFO voltage from affecting AGC voltage, a separate AGC amplifier stage is required. Bias on the 6BJ6 AGC amplifier is higher than normal to prevent overloading at strong signal inputs. Even so the bias is less than .4 of that in the IF cathode follower and less than .2 of that on the final IF amplifier both of which are driven from the same source. When the function switch is in MGC position and RF gain is advanced, the 6BJ6 is the first to draw grid current. To prevent grid current loading the 6BJ6, AVC bias is supplemented by grid leak bias.

### Delay Method

Direct delay on the AGC amplifier or AGC rectifier, has a disadvantage since it permits modulation peaks to affect AGC voltage, particularly at signal levels around AGC threshold. The circuit used in the R-390 prevents this by rectifying the signal first and then delaying the rectified voltage. The delay is accomplished by bleeding B+ on the AGC line. The suppressor grid of the 6BJ6 AGC amplifier acts as a diode to prevent the AGC line from actually going positive for signal levels below AGC threshold.

### Time Constant

AGC voltage after delay, passes through a 220 K ohm resistor to the grid of 1/2 a 12AU7 (V-511A). AGC filter capacitors for the fast position were chosen to keep the receiver stable against audio feedback through the AGC line. The medium time constant is produced by connecting a 2 uf capacitor between AGC line and ground. The slow time constant is produced by connecting this same 2 uf capacitor between grid and plate of V-511A. Because of the "Miller Effect" the input capacitance appears  $C_{gp}(1 + K)$  where K is the gain of the tube. Since the gain of the 12AU7 is about 12, the effective capacitance is increased about 13 times, equivalent to a 26 uf capacitor. Time constants were originally calculated without considering the effect of the delay circuit. Medium and fast time constants were measured indirectly using low frequency AC. Agreement was fairly good between calculations and measurement. However, a recent investigation shows that the delay circuit has a considerable effect on the actual time constant of the system. Time constant should be measured by noting the time required for the AGC line to discharge to  $e^{-1}$  times the original AGC voltage. Lately the medium and fast time constants have been measured in this manner with results showing that the fast AGC time constant is actually .015 seconds, and the medium constant is about .2 seconds. Slow AGC time constant is 3.5 - 4 sec. The drawing of the Functional circuit will help to illustrate the reason that the AGC T.C. is affected by the delay circuit. (Figure 66).

If the delay circuit were absent the discharge TC would be equal to  $RC = (180 K + 220 K + 100K) 2 \text{ uf} = 1.0 \text{ sec}$ . If the delay diode were absent and no AGC voltage were being generated the voltage at the point A would be  $+180 \times \frac{280}{1280} = +39.5 \text{ V}$ . The delay diode (suppressor of the 6BJ6 AGC amplifier) prevents this voltage from rising above +7.5 V, but this is enough to speed up the discharge of the 2 uuf capacitor considerably over what it would be if the capacitor were discharging toward ground.

### Flat AGC Characteristics

Four tubes provide good control of receiver gain up through .1 volt. Beyond this point the AGC no longer holds the receiver within the required spec of 6 db between 2.5 uv and 1 v. Beyond .3 v input, modulation rise occurs and the AGC amplifier begins to overload. It is possible to hold audio to within 6 db from 2.5 uv to .1 v and within 12 db from 2.5 uv to 1 v.



Blocking

In order to prevent grid current flow in the first RF amplifier, it has already been pointed out that the AGC voltage must be allowed to rise to 11.5 v at 1 v input. In addition, all other gains and attenuations must be apportioned so that no other stage draws grid current. After some experimentation this has been accomplished and at no time does the receiver block with inputs under 1 volt.

Carrier Level Meter

The carrier level meter is actuated by the plate current flow in V511A, the time constant multiplier tube. Meter current flow is balanced out under zero AGC voltage conditions by means of a bridge circuit. Application of AGC voltage to the grid of V511A reduces the voltage on its cathode allowing current to flow through the meter in proportion to the magnitude of AGC voltage. Figure 67 shows the functional circuit operation of the carrier level meter circuit. The 15 ohm rheostat in the 6AK6 final IF amplifier cathode zeros the meter under conditions of zero AGC voltage. A meter reading when function switch is in MGC position indicates an overload of V506. It is caused by grid current flow in V506 which added to the plate and screen current unbalances the bridge.

4.2.11.2 Noise Limiter

Upon request of the Signal Corps, a full wave adjustable noise limiter was adapted for use in the R-390 receiver. This type of noise limiter has the advantage that the clipping level can be adjusted from a rather high modulation percentage (50 - 60%) suitable for removing impulse noise from AM signals, to a very low percentage useful on CW signals. Figure 69 shows the functional circuit diagram of the noise limiter in operation.

4.2.11.3 R-390 VFO Filter

With the type of circuitry employed in the R-390 receiver, the VFO frequency coincides with the receiver frequency at 2.727 and 3.227 mc. In addition, the receiver is very often tuned to harmonics of the VFO. In order to hold down noise and spurious responses it is necessary that the third mixer be supplied oscillator voltage in which IF noise and oscillator harmonics are filtered out. The most obvious way of doing this is to place a tuned circuit between VFO and mixer, but because of mechanical problems, such a filter would be placed in the RF chassis rather than the VFO. This was tried, but as a result of the high VFO voltages on the RF unit, the oscillator crossovers were very strong indeed. Further experimentation led to a bandpass filter mounted on the VFO. IF noise is attenuated 28 db, and the second harmonic of the VFO is down 14 db or more. Since this removes high VFO voltage from the RF chassis, fundamental crossovers are also reduced in intensity. Figure 70 shows the circuit of the filter.



### Lead Filtering

All VFO power leads have been carefully filtered to reduce VFO fundamental and harmonic radiation to a minimum. Despite careful filtering and lead shielding, internal signals produced by coincidence of VFO fundamental or harmonics with the receiver frequency signals occasionally run as high as 3.5 uv equivalent strength. The following performance on internal signal strength was the best possible:

NMT 8 signals > .5 uv

NMT 5 signals > 1 uv

NMT 2 signals > 2 uv

0 signals > 3.5 uv

### 4.3 Task C Drawing and Report

The final work of this project was to complete the drawings necessary to give complete manufacturing information for both of these receivers and their various accessories. All during the model building program, drawings were used but they were mostly of the temporary sketch nature. This was necessary because of the many changes made during development. Toward the last of the project, final drawings were prepared both for this project and for manufacturing purposes. This work was done mostly by draftsmen who worked under the supervision of the mechanical engineers listed in this contract. This work continued some time after the last of the equipments were submitted to the Signal Corps so the drawings are among the last items to be delivered.

This final report was not started until all equipments were delivered and preparation for manufacture of these equipments was underway. Most of the personnel who worked on the development contract were also involved with the production so it has been difficult to get this report together and out on schedule.

### 5.0 CONCLUSIONS

The following are the results of this development contract and the conclusions reached by the Contractor as a result of this work:

5.1 As a result of this development contract, design has been completed, models built, and manufacturing drawings prepared for two basic radio receivers, the R-389/URR and the R-390/URR. These receivers were designed to meet the Signal Corps specifications SCL-1134-B and MIL-R-10474. While they do not meet these specifications in every respect, they have satisfied the Signal Corps requirements to the extent that substantial orders have been placed with the Contractor for both equipments. There were also developed several accessories for these basic receivers such as special power supplies and cabinets, some of which are also being ordered by the Signal Corps.

Courtesy of <http://BlackRadios.terryo.org>

5.2 It was concluded that the "unitized" or "sub-assembly" design was of great importance and during this program a great deal of work was done with this type of construction. From this experience the desirability of this type of construction has been clearly shown. Both manufacture and maintenance have been found much simpler when sections can be built and serviced separately.

5.3 Another conclusion which can be drawn from experience on this equipment is that the use of quite complicated systems, both electrical and mechanical, can be tolerated by the military services, in order to achieve desired performance. This was a point of some concern during the planning phases since it was felt that over complicated equipment would be undesirable even though it might meet the requirements. At just what point compromises can be made is not easily determined but future use of this equipment should give more information on this subject.

## 6.0 RECOMMENDATIONS

The following recommendations are made as a result of the Contractor's experience in developing this equipment:

6.1 In a development project of this kind where a group of engineers design and build a piece of equipment, there is one problem always to be faced. That is, to decide at what point in design, work can be stopped and it can be definitely said that this is it. Of course, the design objectives and specifications should be the answer to the problem, but no good engineer who is striving for the optimum in his design likes to stop work when he can see further improvement possible even though minimum design objectives have been met. However, in this equipment where production schedules demanded completion of the design, it is felt that further investigation and design would be worth while especially in the simplification of assembly and maintenance. It is also felt that a general review of requirements be made keeping in mind the complications necessary to meet each requirement. One specific point which might be investigated under such a program is the RF unit. This unit, because of its complicated gear train and so many moving parts, could be studied for possible relaxing of tolerances and simplification of assembly methods. The mixer circuit could also be investigated for a way of reducing spurious responses and internal signals. The antenna circuit gain and impedance might be improved by further work. The development of better iron cores might help the RF coil design enough to result in lower manufacturing costs. A redesign of the crystal oscillator unit might increase the accessibility of parts and ease assembly. In the IF unit a redesign could be made using newly developed "mechanical filters" to replace the IF transformers and eliminate alignment problems both in manufacture and field maintenance. The audio unit, which now has a concentration of heat due to tube dissipation, might be redesigned to relieve this trouble. The VFO has certain drift problems which might be reduced by new and better iron cores. The calibrator unit should also be checked for tube and component aging. So in general, it is recommended that future development work be done in order to insure optimum performance and minimum costs for all parts of these equipments.

6.2 Another thing recommended is that the most be made of the unitized type of construction of these receivers. To do this, complete spare units should be stocked for rapid replacement. Special test fixtures should be provided in order to simplify maintenance and repair of individual sub-assemblies. Extension cables should be provided for operation with units removed for checking or repair. Special test information should also be provided for such testing, and locating trouble by unit should be emphasized.

6.3 It is also recommended, since this equipment employs several relatively new techniques, that these be incorporated into the Signal Corps training program as soon as possible. Schooling on such things as permeability tuning and triple conversion would be a big help in use and maintenance of these equipments.

6.4 It is also recommended that development work be initiated or accelerated on several components which were found to be limiting factors in this design. In the case of the first RF tube, a compromise had to be made between sensitivity and overload performance since no tube was available which would give good performance in both points. The tube used in the variable frequency is also one of the limiting points for frequency stability of these receivers and development work on a special oscillator tube might give improved operation. Also the iron core used in this oscillator is the best available for aging and stability, yet it is felt that development work on iron cores could find materials which would give better results. It would also seem advisable that other manufacturers be set up to build ballast tubes similar to the ones used in this equipment and now available from only one supplier.

So here also a general recommendation is made that a great deal of emphasis be put on research and development programs to provide new and improved components for the electronic designs. The Signal Corps has given excellent cooperation through their Component and Material Section on this point and have been of great help in solving component problems. However, there is still a lot to be done and could prove to be a benefit to all concerned.

## 7.0 IDENTIFICATION OF PERSONNEL

The following is a list of names and titles on key personnel directly assigned to this contract and taking part in the work covered by this report. This list also contains the approximate number of man hours spent and the major work of each man. Also included is a brief description of the background of each man.

### L. W. Couillard - Section Head, Medium Frequency Receiver Section

Employed by Collins Radio Company for 12 years working mostly on receivers and receiving equipment. Graduate in Electrical Engineering, University of Minnesota, 1938. Approximately 1500 hours spent on this project working on all phases in a supervisory capacity.



Courtesy of <http://BlackRadios.terryo.org>

R. F. Witters - Project Engineer on R-389 Receiver

Employed by Collins Radio three years working on the R-389 receiver. Graduate in Electrical Engineering from Northwestern University in 1944. Employed three years by Rauland Corp. as project engineer and by Galvan Manufacturing Corp. one year as production engineer. Approximately 4500 hours spent on this project working on the R-389 receiver.

D. M. Lewis - Mechanical Engineer

Employed by Collins Radio four years working on mechanical design of R-389. Graduate in Mechanical Engineering from Iowa State College. Previously employed by Curtis Wright Corp. for five years as a mechanical engineer on aircraft electrical equipment. Approximately 4500 hours spent on this project doing mechanical design.

R. L. Stimson - Development Engineer

Employed by Collins Radio for three years working on R-389 receiver. Graduate in Electrical Engineering from Indiana Tri-State College, 1948. Approximately 600 hours spent on this project working on the R-389 RF section.

N. E. Hogue - Project Engineer R-390 Receiver

Employed by Collins Radio for three years working on R-390 equipment. Graduate in Electrical Engineering from University of Wisconsin in 1950. Approximately 3000 hours spent on this project working on the R-390, particularly on the audio and power units.

E. Schoenike - Development Engineer

Employed by Collins Radio four years working on R-390 equipment. Graduate in Electrical Engineering from University of Wisconsin in 1949. Approximately 4500 hours spent on this project working mostly on the RF and oscillator sections.

W. R. Griswold - Mechanical Engineer

Employed by Collins Radio for four years working mostly on the mechanical design of Navigation and receiving equipment. Graduate of special drafting and mathematics course, Minnesota, 1936. Graduate of aviation school, Hamlin University, 1945. Employed four years as architect, Minneapolis, Minnesota and five years as mechanical designer by Minneapolis Honeywell Regulator Co. Approximately 3000 hours spent on this project working mostly on the mechanical design of the R-390.



C. A. Rockwell - Development Engineer

Employed by Collins Radio for 13 years working as a laboratory technician, assembly foreman, and development engineer. Approximately 3000 hours spent on this project working mostly on RF coil design for R-390 receiver.

A. E. Eberhardt - Development Engineer

Employed by Collins Radio three years working on R-390 project. Graduate in Electrical Engineering from Purdue University 1949. Two years spent in U.S. Army as Technical Sgt. Approximately 1500 hours spent on this project working mostly on the IF unit design.

R. Newmire - Development Engineer

Employed by Collins Radio for eight years as test foreman and development engineer. Approximately 600 hours spent on this project, working mostly on spurious response problems and test work.

D. M. Hodgkin - Development Engineer

Employed by Collins Radio for six years working on oscillator development. Graduate in Electrical Engineering from Purdue University in 1947. Served two years as radio technician in U.S. Navy. Approximately 900 hours spent on this project doing development work on variable frequency oscillators for R-389 and R-390 receivers.

R. Craiglow - Development Engineer

Employed by Collins Radio for approximately six years specializing in crystals. Graduate of Ohio State University in Electrical Engineering in 1947. Served two years in U.S. Signal Corps. Approximately 200 hours spent on this project doing work on crystal circuits.

H. Stover - Development Engineer

Employed by Collins Radio for three years working on oscillator development. Graduate of Iowa State College in Electrical Engineering, 1950. Served two and one-half years in U.S. Signal Corps. Approximately 300 hours spent on this project working mostly on the beat frequency oscillator circuits.

Figure 1. Typical Triple Conversion System

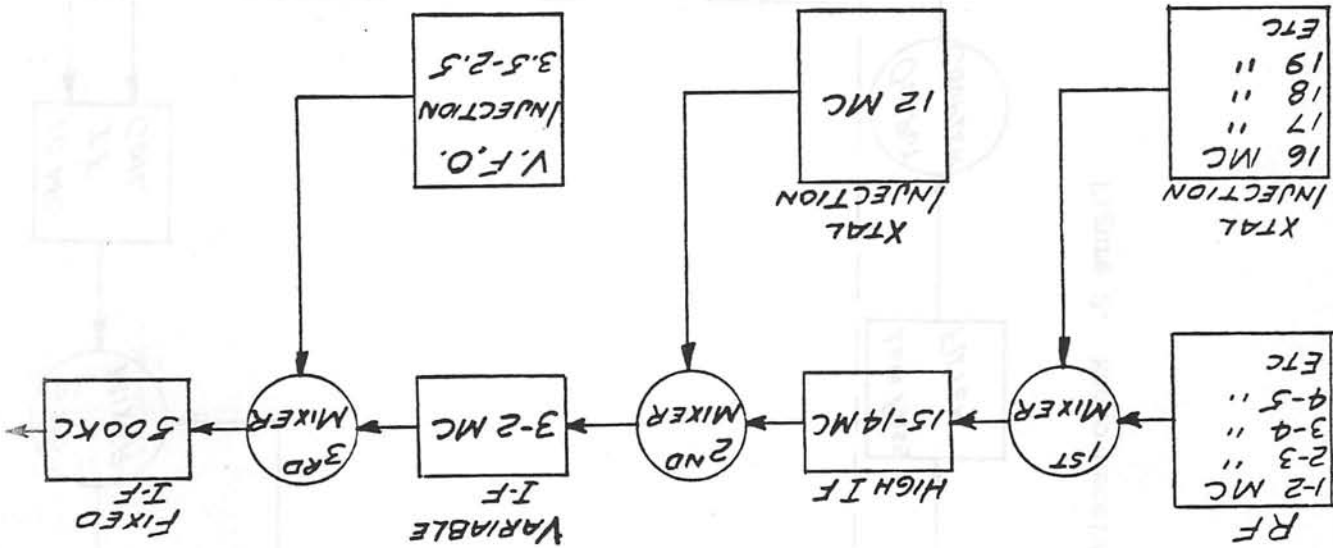

BASIC FREQUENCY SYSTEM

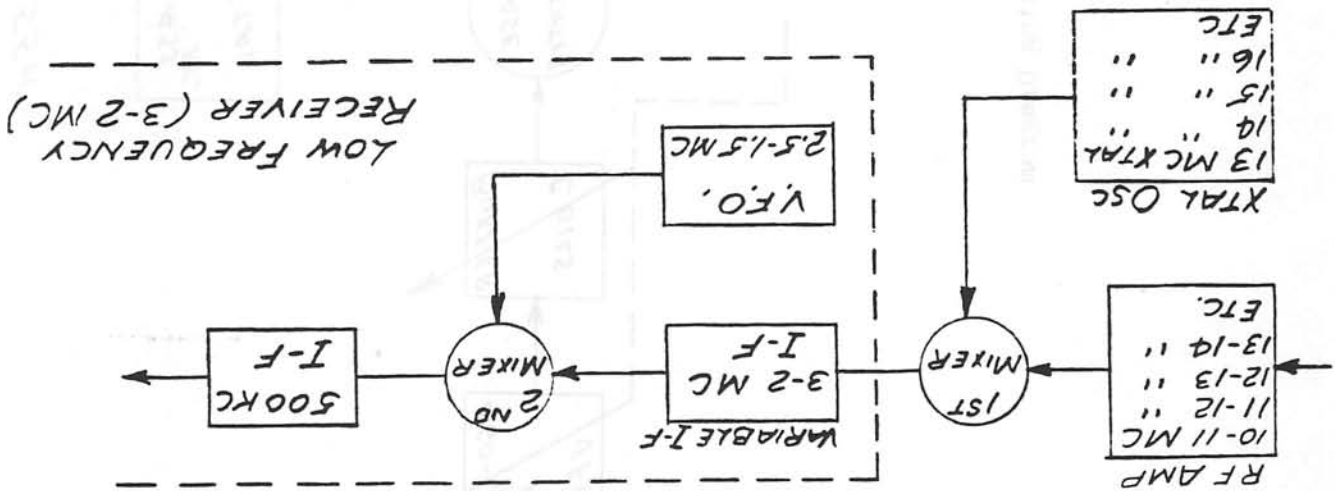

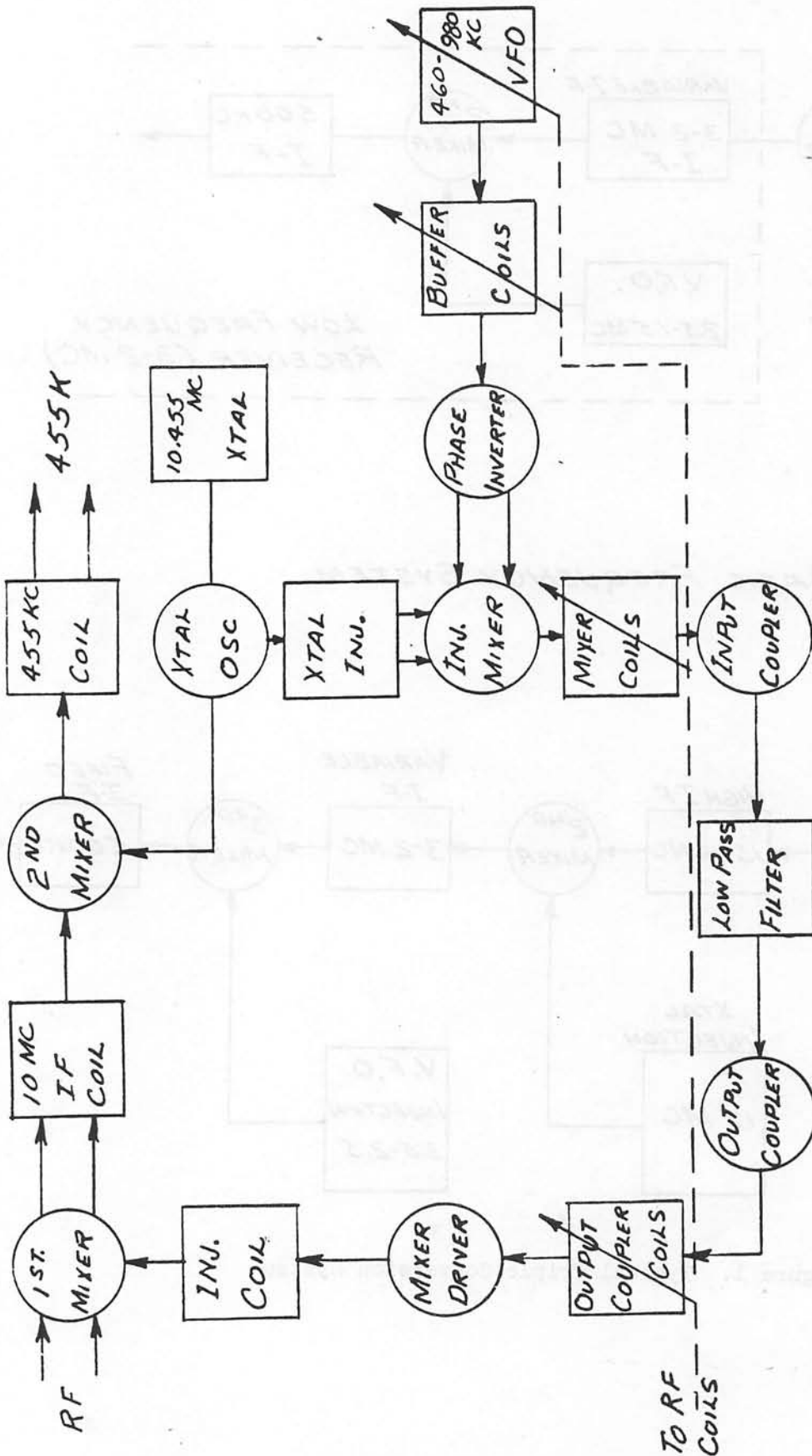

Figure 2. Radio Receiver R-389/JRR Final Mixing Diagram

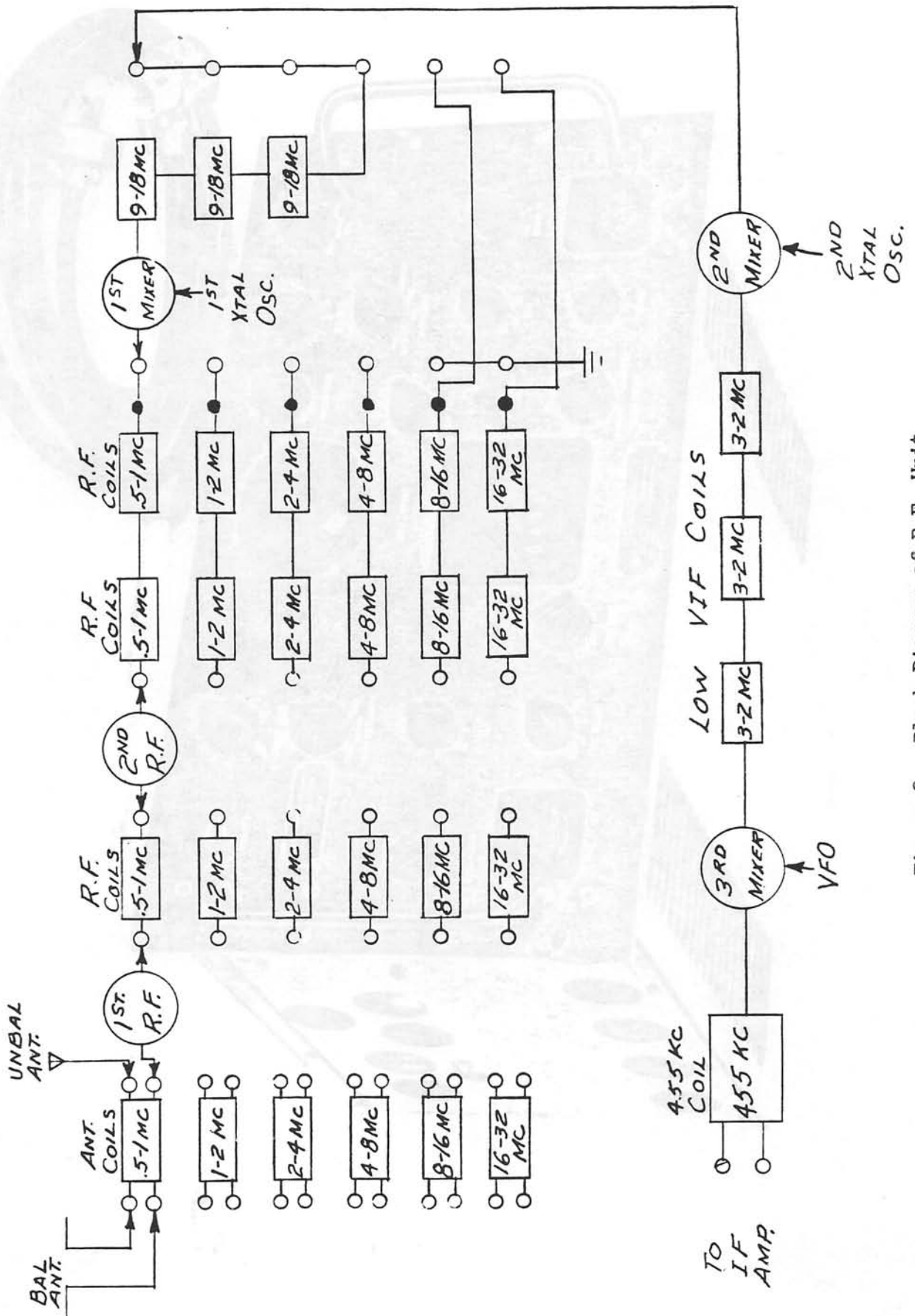
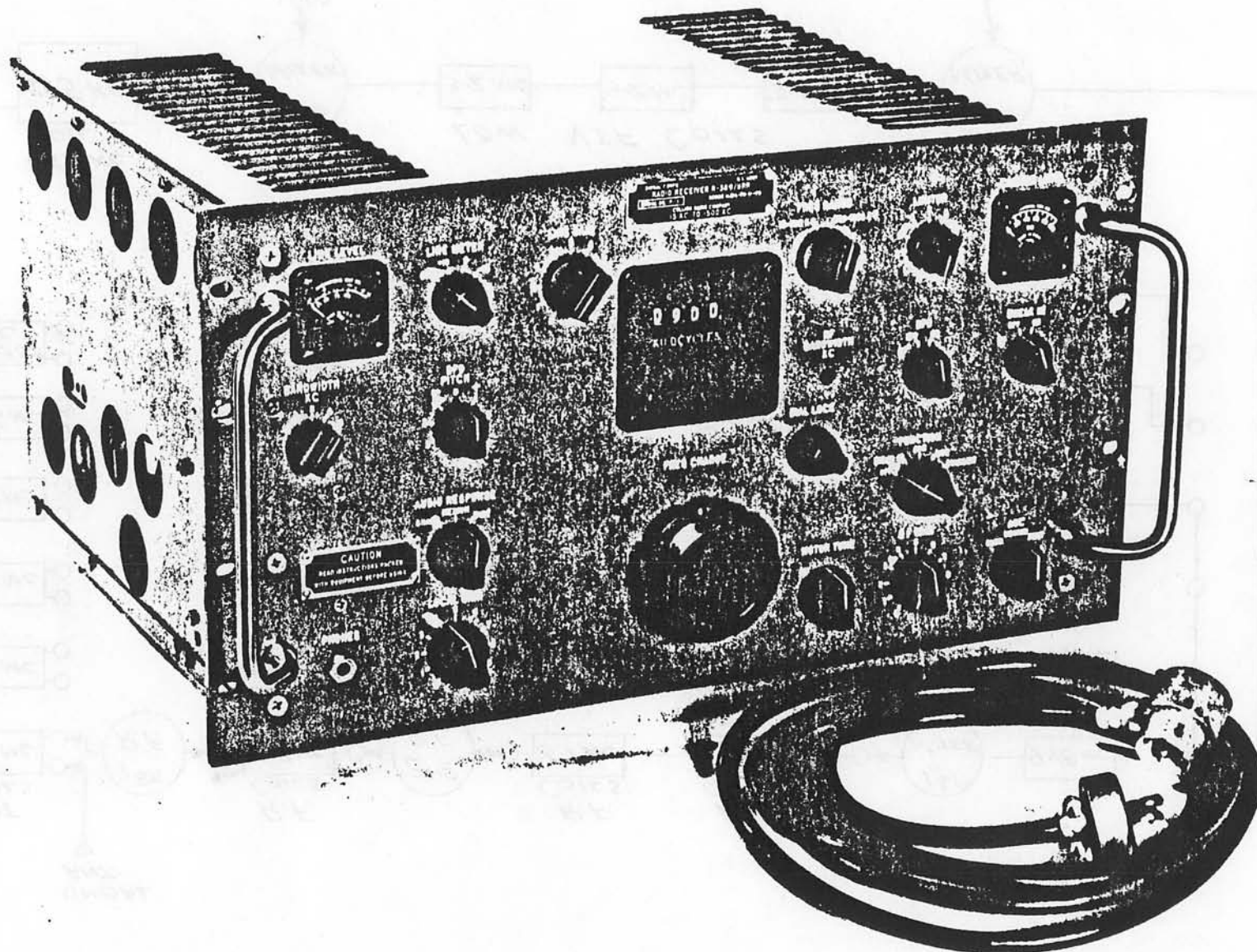

Figure 3. Block Diagram of R.F. Unit



Courtesy of <http://BlackRadios.terryo.org>

RESTRICTED



SECURITY INFORMATION - RESTRICTED

Figure 4. Radio Receiver R-389/URR, Front View

Courtesy of <http://BlackRadios.terryo.org>

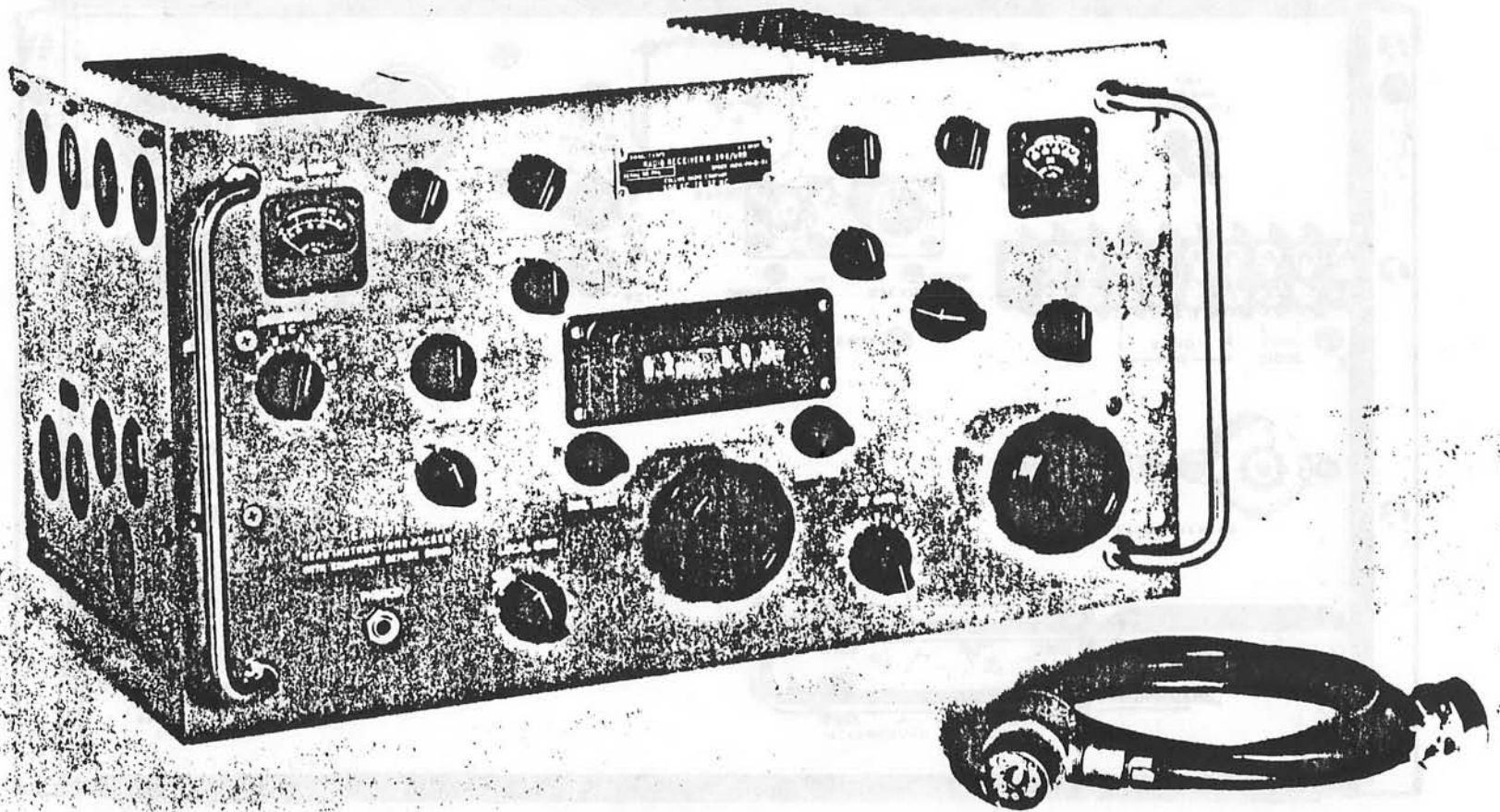

RESTRICTED

SECURITY INFORMATION - RESTRICTED

Figure 5. Radio Receiver R-390/URR, Front View

Courtesy of <http://BlackRadios.terryo.org>

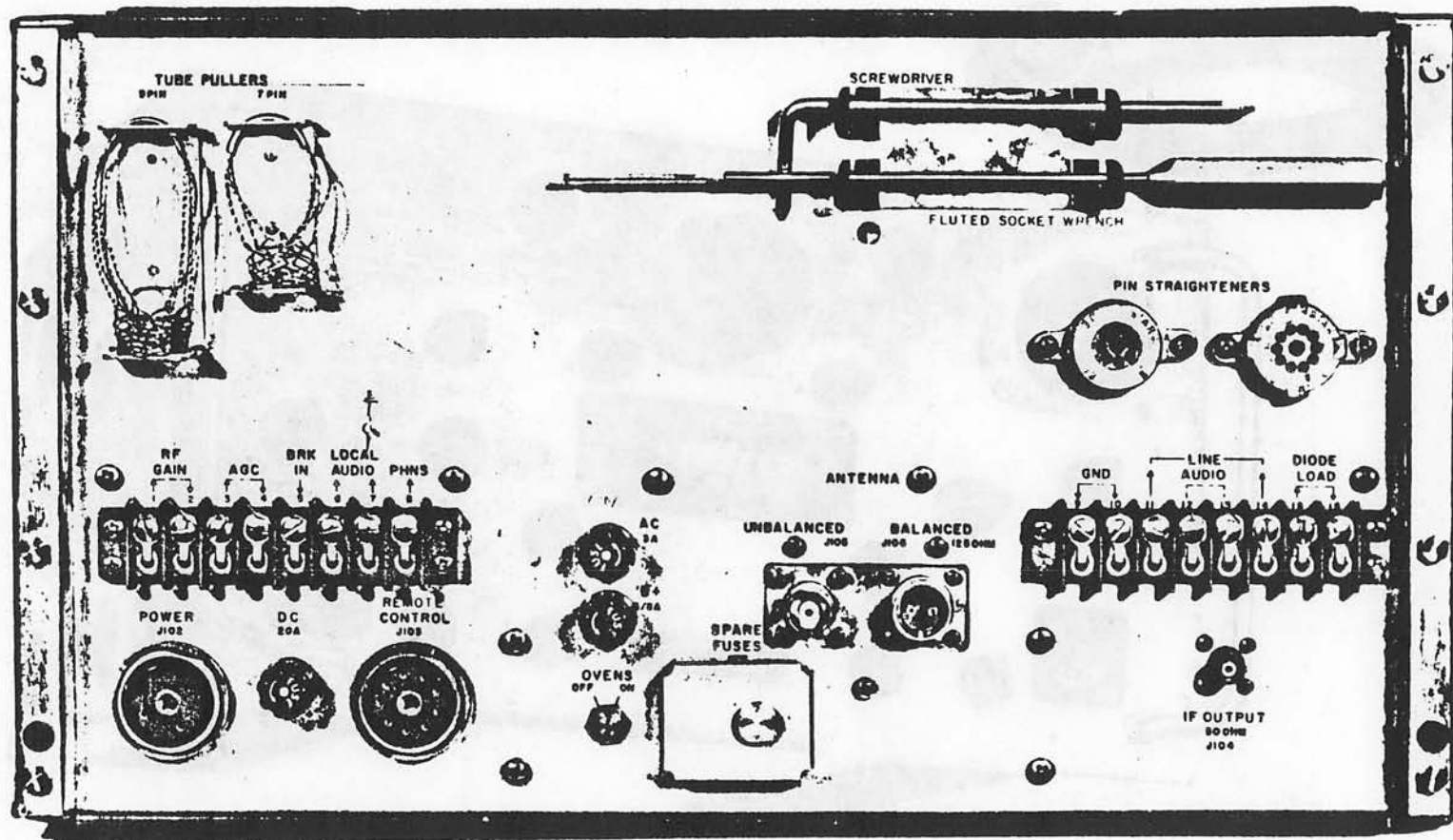

RESTRICTED

SECURITY INFORMATION - RESTRICTED

Figure 6. Radio Receiver R-389, Rear View

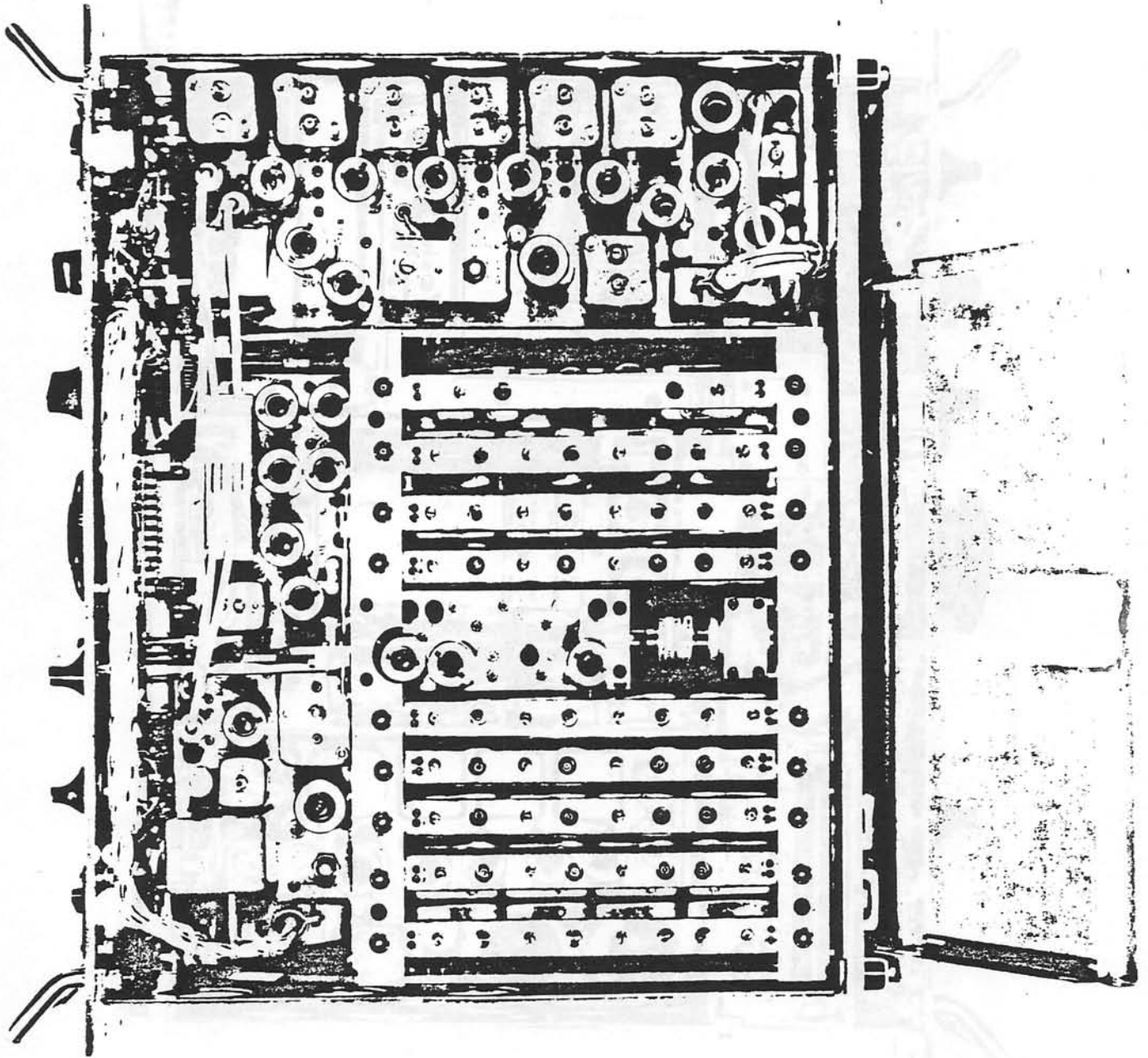



Courtesy of <http://BlackRadios.terryo.org>

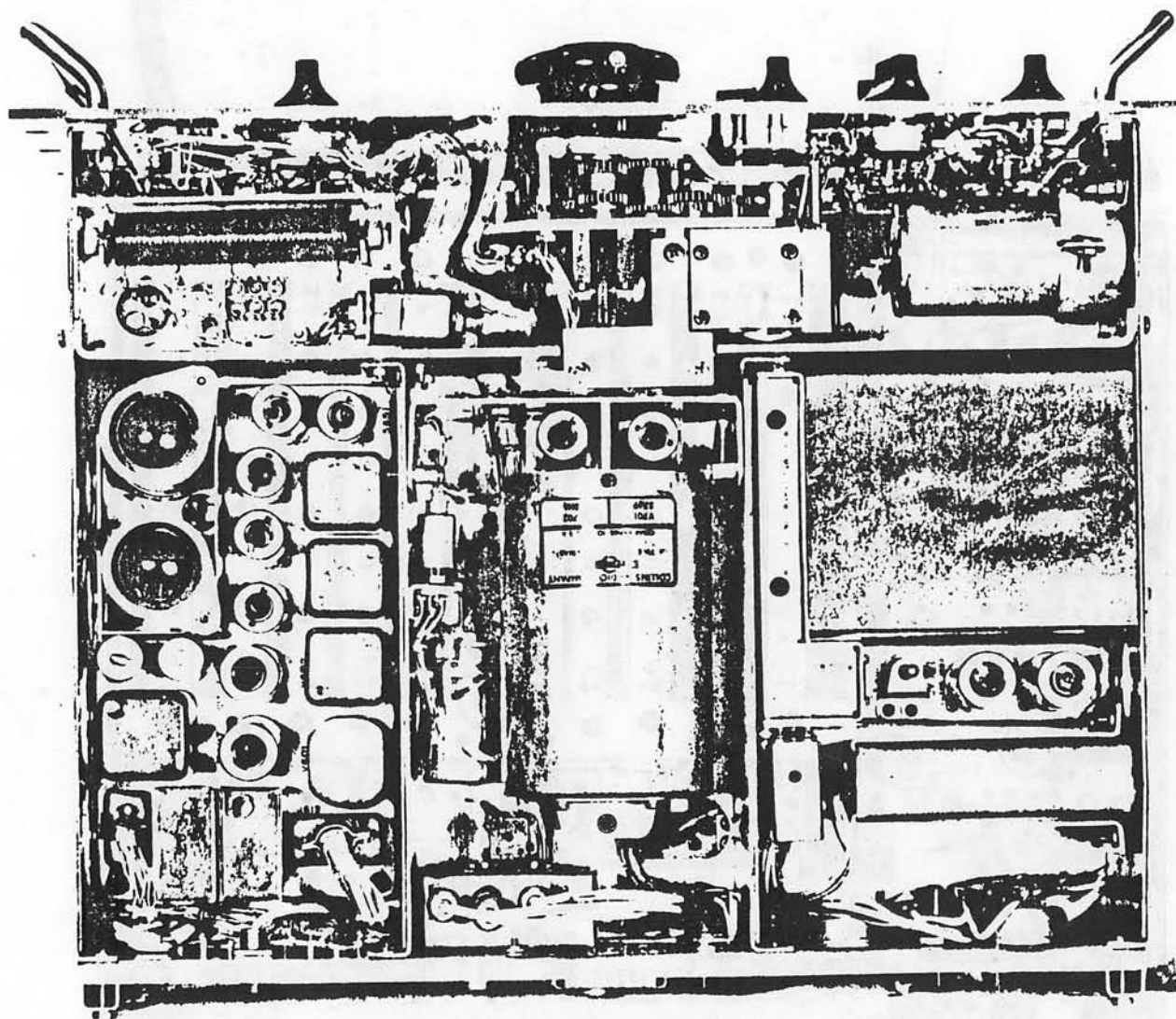

RESTRICTED

SECURITY INFORMATION - RESTRICTED

Figure 8. Radio Receiver R-389/URR, Bottom View

Courtesy of <http://BlackRadios.terryo.org>

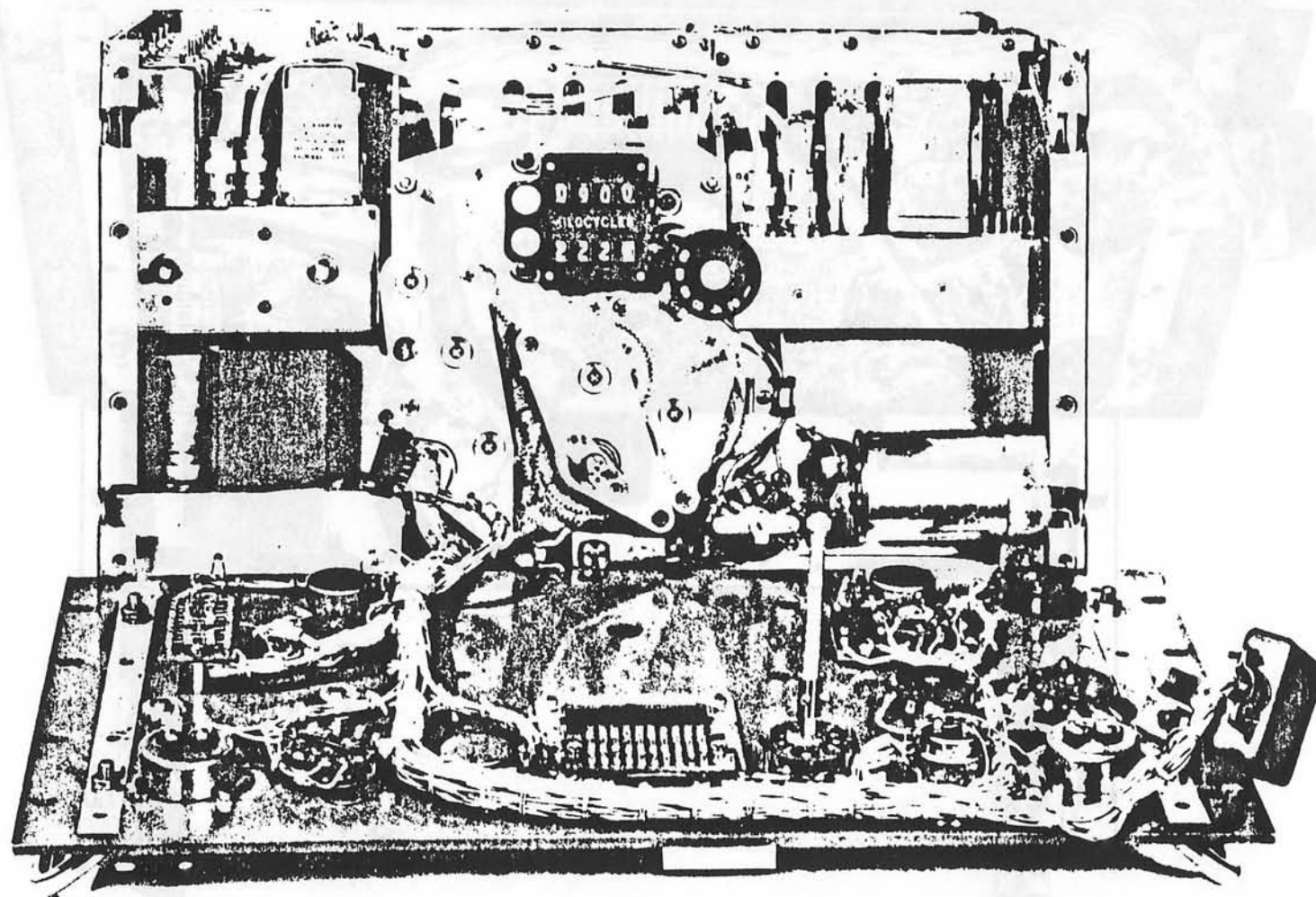

RESTRICTED

SECURITY INFORMATION - RESTRICTED

Figure 9. Radio Receiver R-389/URR, Front View - Panel Removed

Courtesy of <http://BlackRadios.terryo.org>

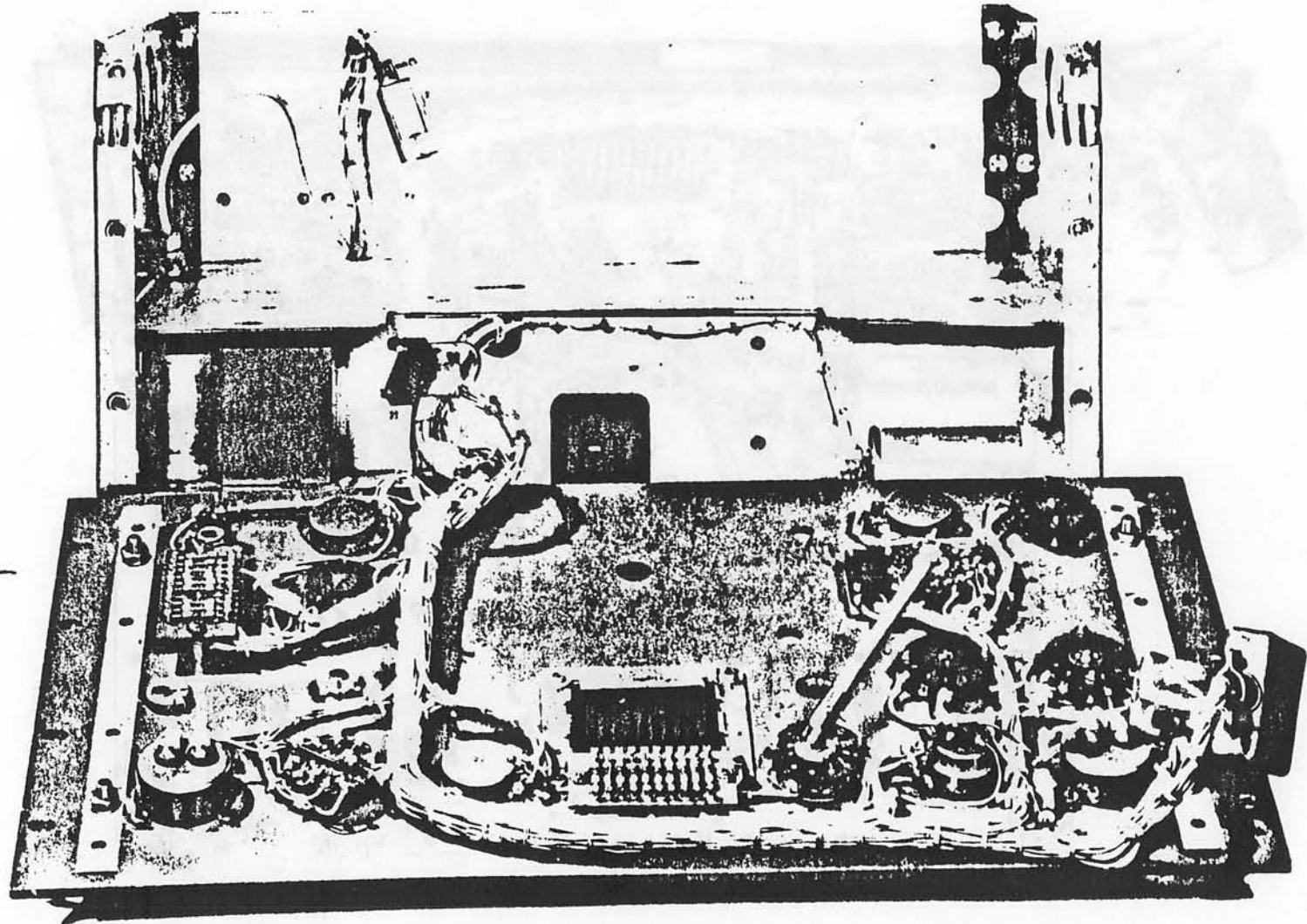

RESTRICTED

SECURITY INFORMATION - RESTRICTED

Figure 10. Radio Receiver R-389/URR, Front View - Unit Removed

Courtesy of <http://BlackRadios.terryo.org>

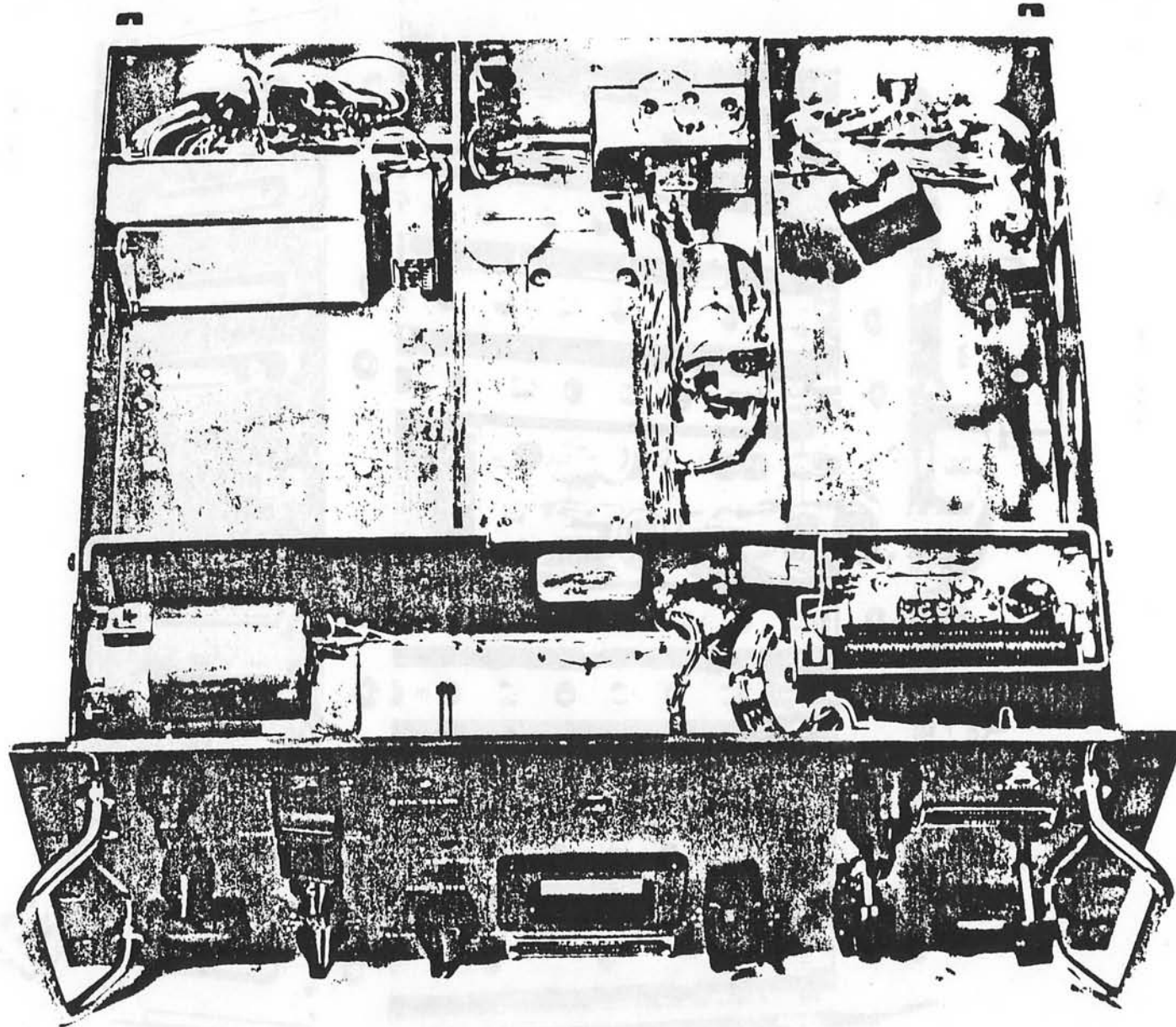

RESTRICTED

SECURITY INFORMATION - RESTRICTED

Figure 11. Radio Receiver R-389/URR, Bottom View - Units Removed



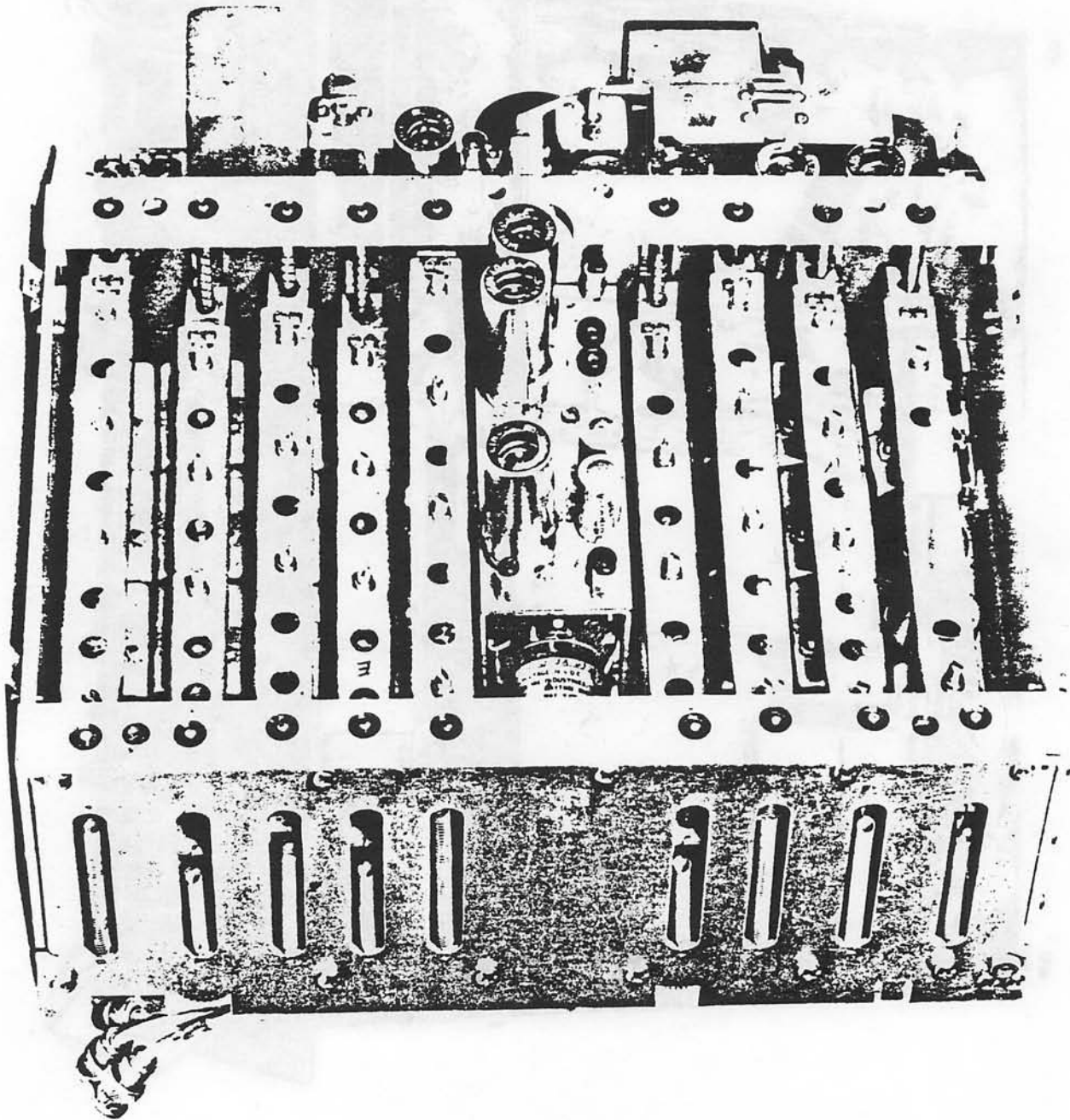

Figure 12 Radio Receiver R-389/URR, R-F Unit - Rear View

Courtesy of <http://BlackRadios.terryo.org>

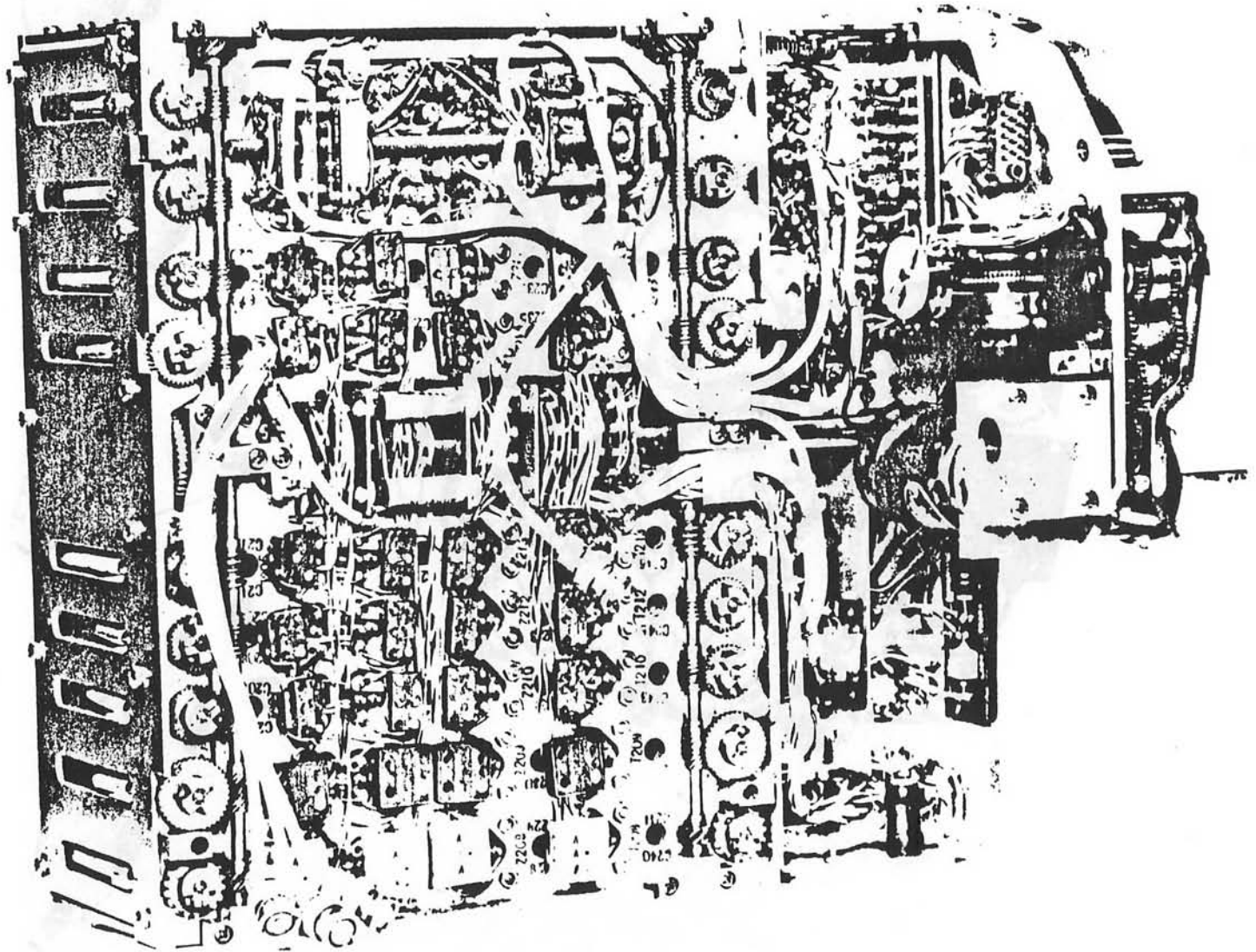

Figure 13 Radio Receiver R-380/IRR, R-F Unit - Bottom View

RESTRICTED

SECURITY INFORMATION - RESTRICTED

Courtesy of <http://BlackRadios.terryo.org>

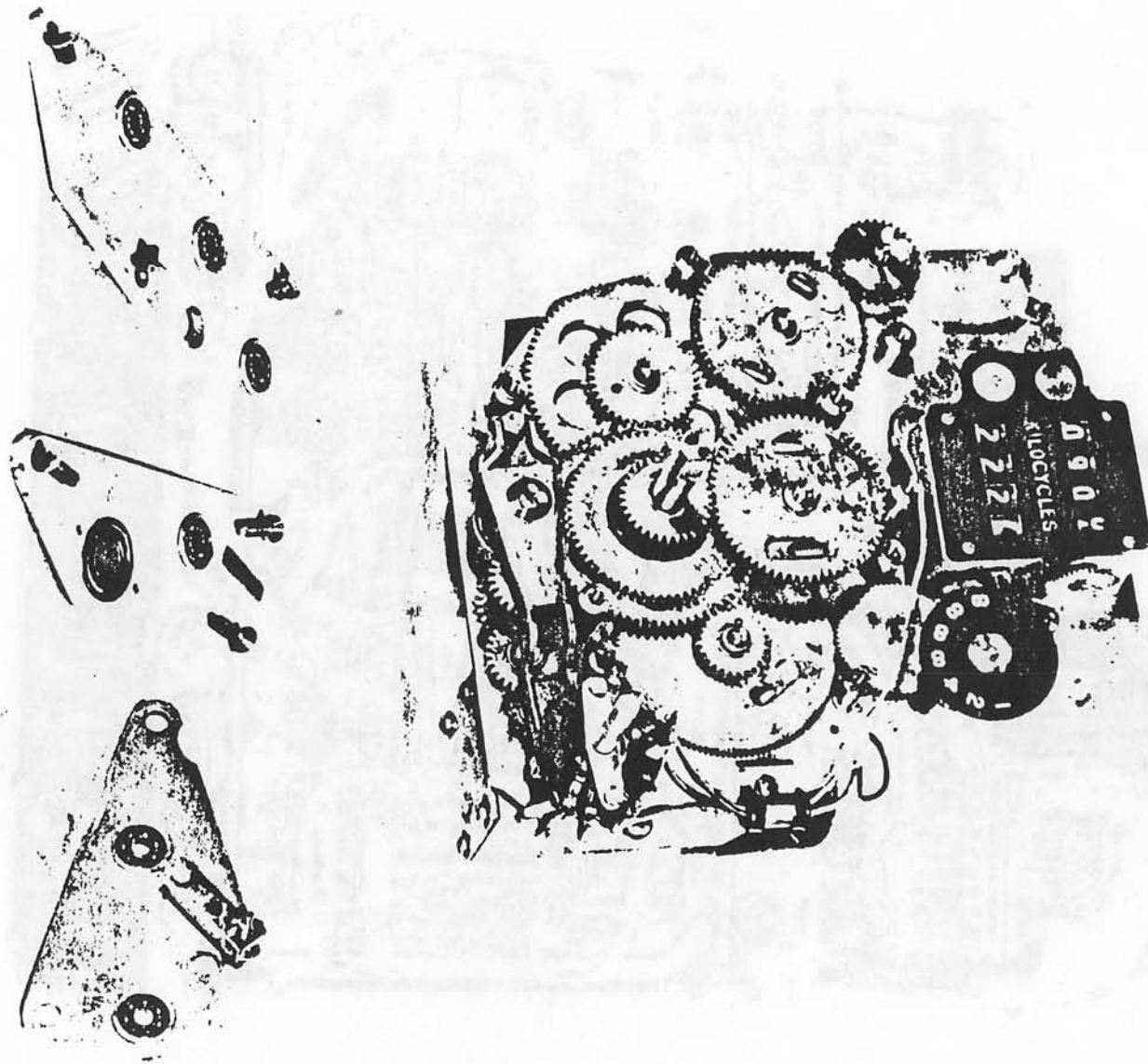
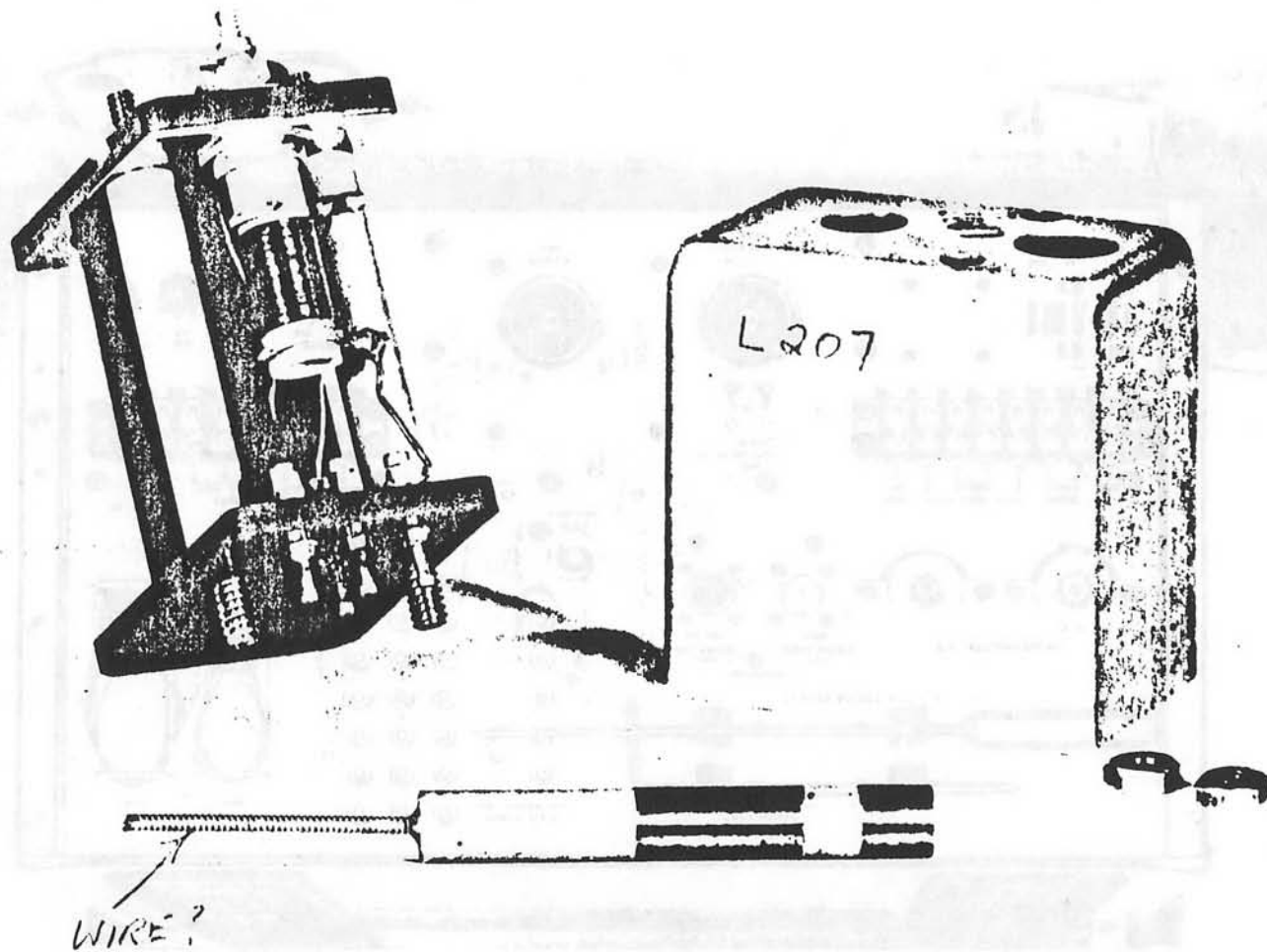

Figure 14. Radio Receiver R-389/URR, Gear Train

RESTRICTED

SECURITY INFORMATION - RESTRICTED

Courtesy of <http://BlackRadios.terryo.org>



RESTRICTED

SECURITY INFORMATION - RESTRICTED

Figure 15. Radio Receiver R-389/URR. R-F Coil



Courtesy of <http://BlackRadios.terryo.org>

RESTRICTED

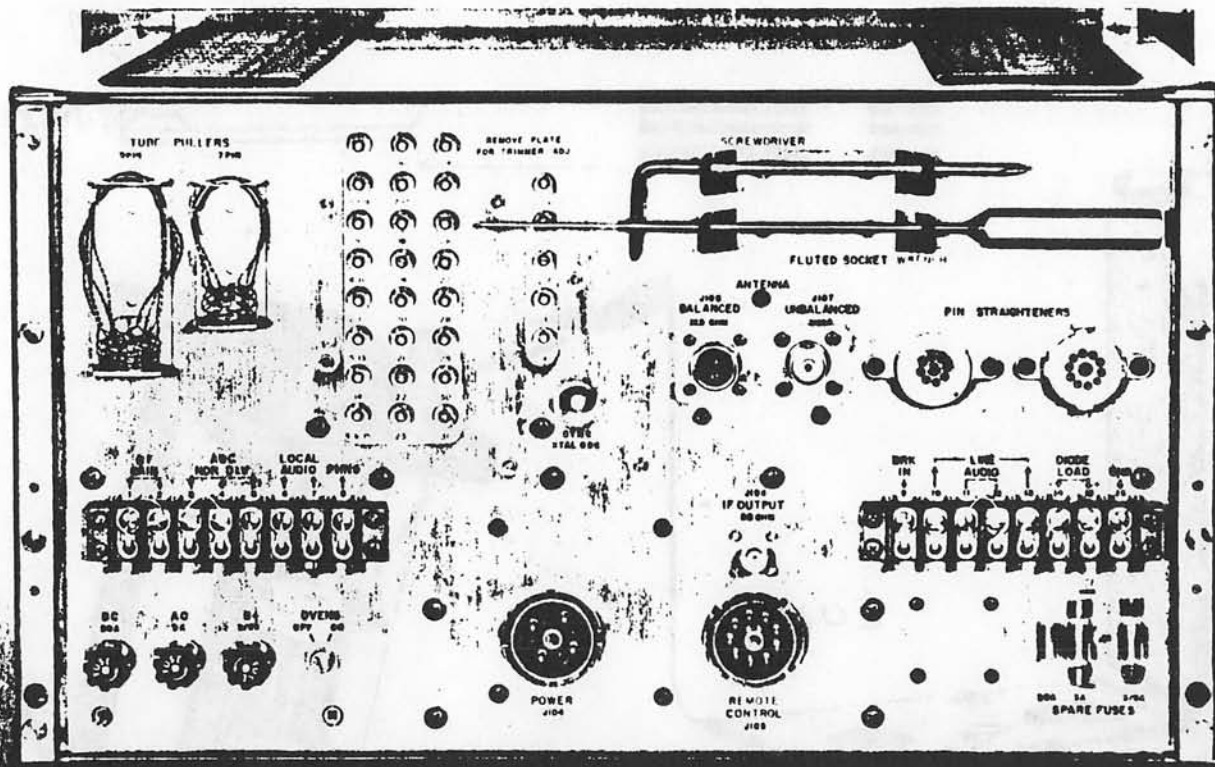

SECURITY INFORMATION - RESTRICTED

Figure 16. Radio Receiver R-390/URR, Rear View

Courtesy of <http://BlackRadios.terryo.org>

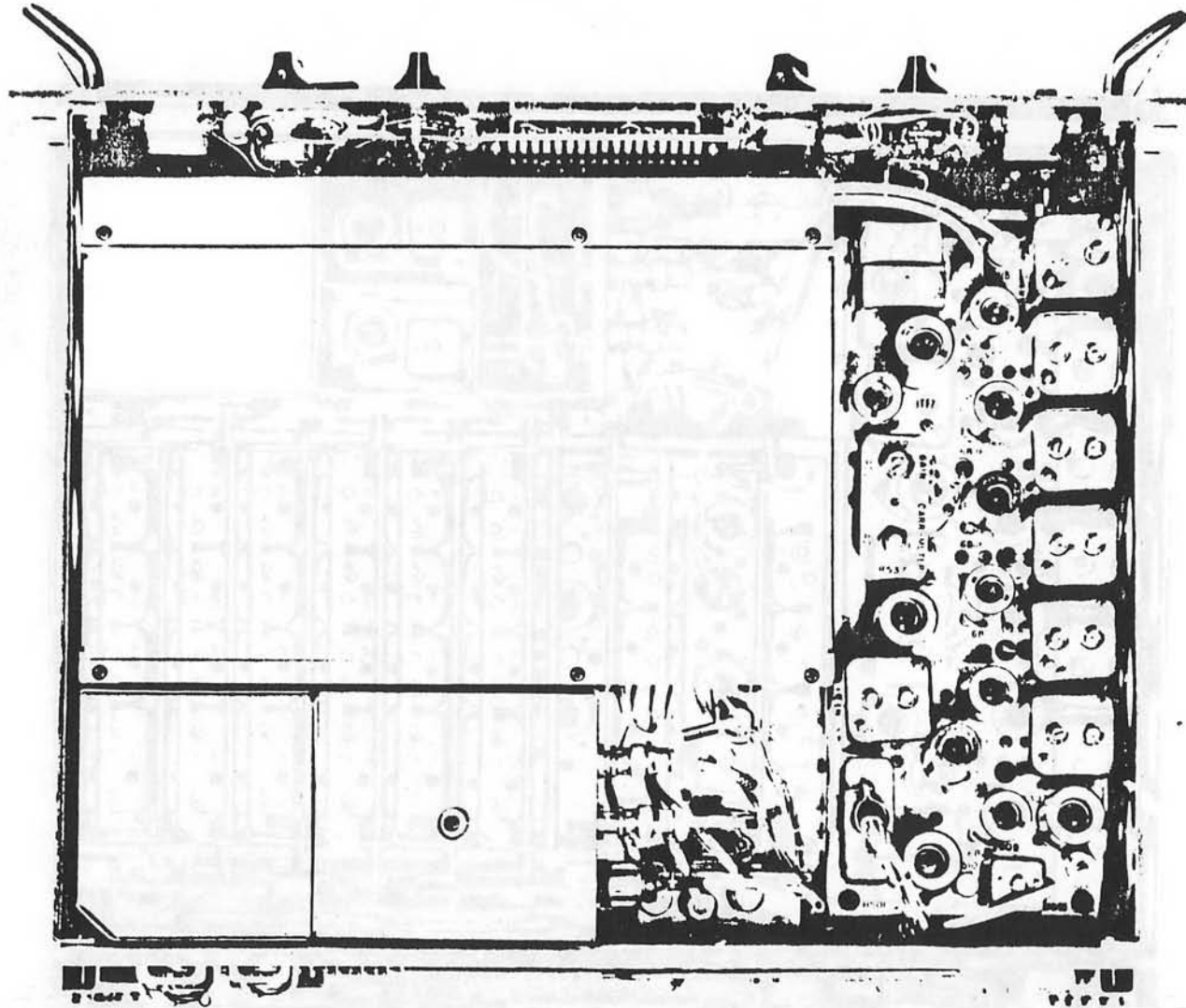

RESTRICTED

SECURITY INFORMATION - RESTRICTED

Figure 17. Radio Receiver R-390/URR, Top View

Courtesy of <http://BlackRadios.terryo.org>

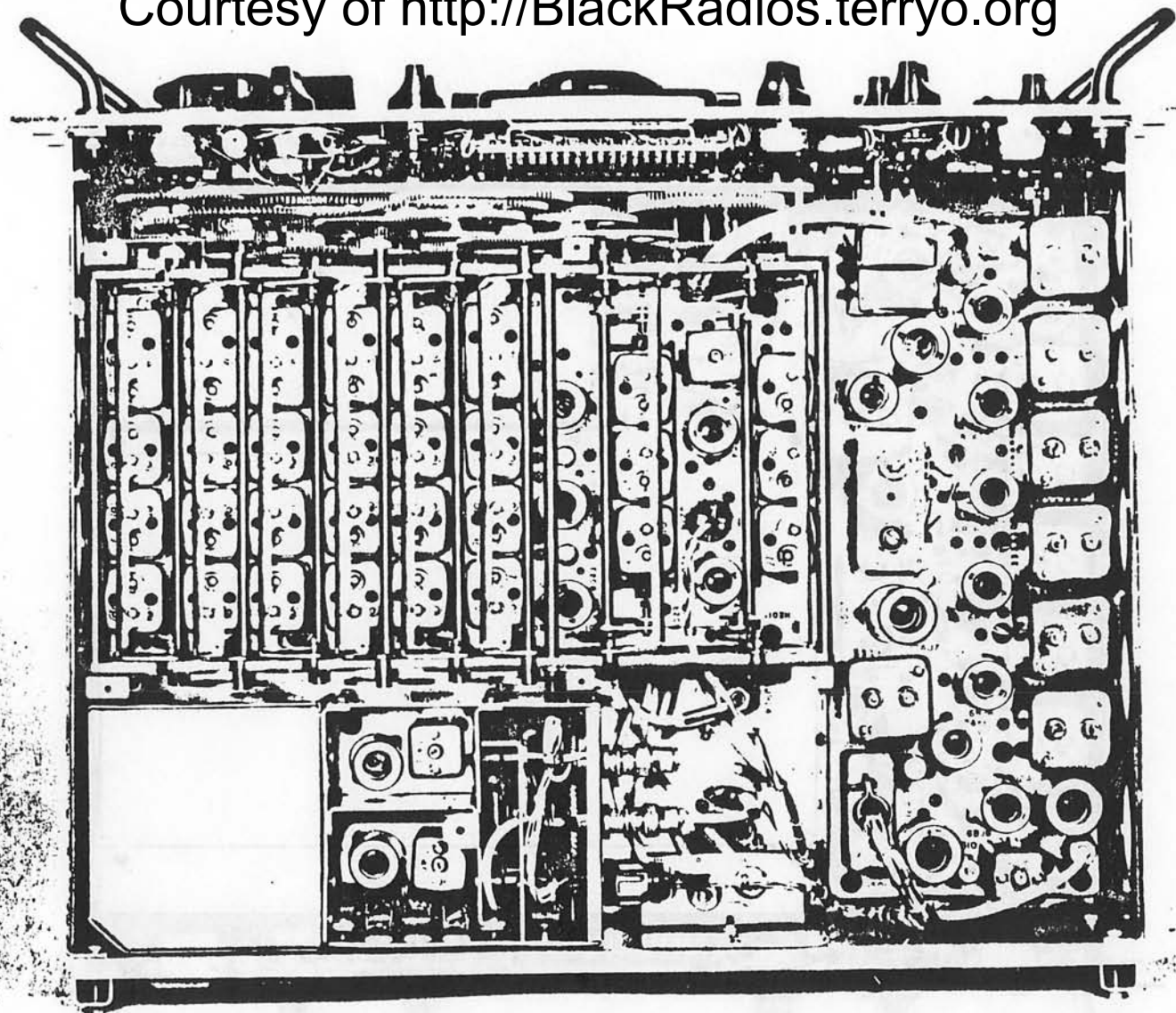

RESTRICTED

SECURITY INFORMATION - RESTRICTED

Figure 18. Radio Receiver R-390/URR, Top View - Shield Removed

Courtesy of <http://BlackRadios.terryo.org>

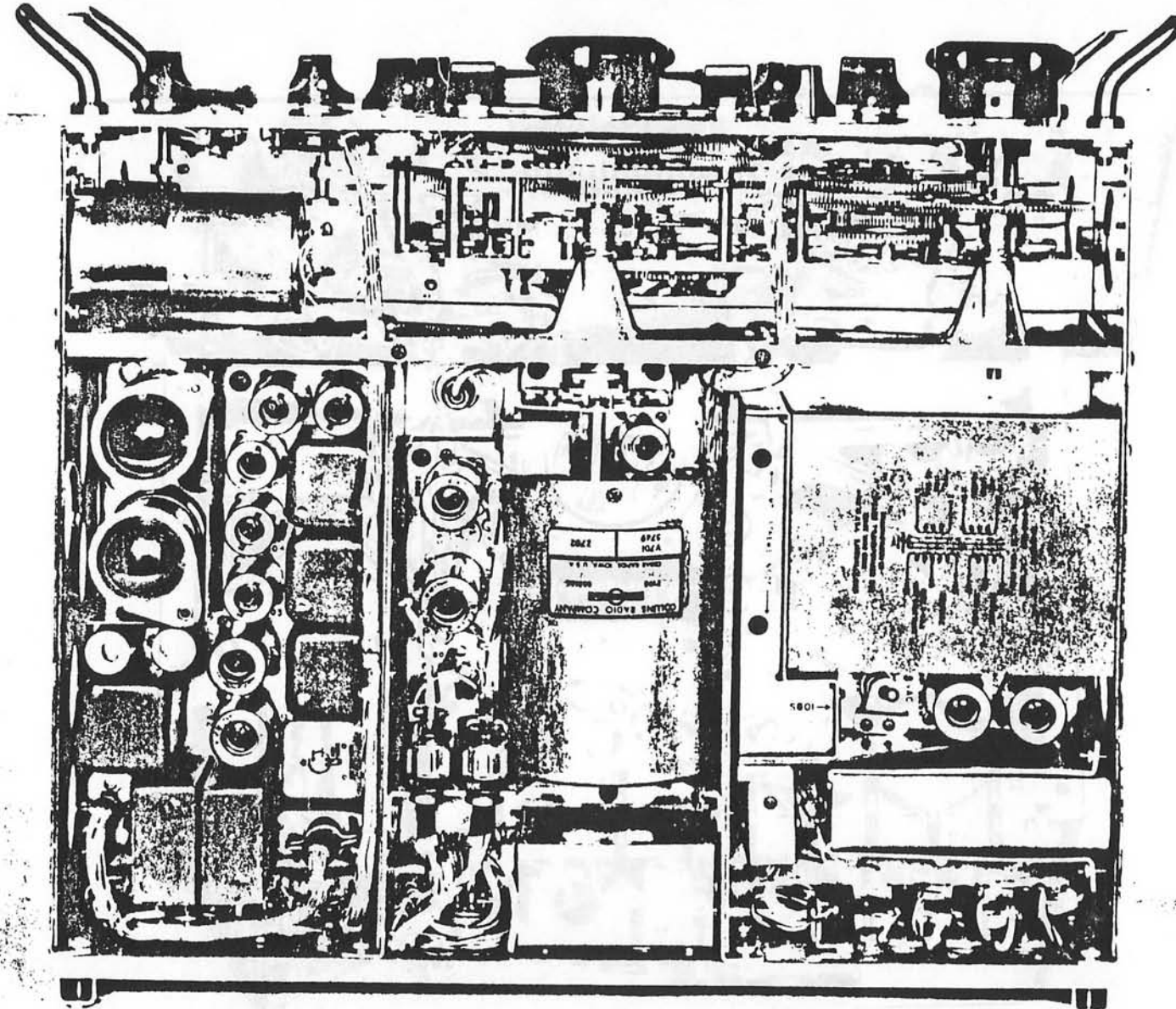

RESTRICTED

SECURITY INFORMATION - RESTRICTED

Figure 19. Radio Receiver R-390/URR, Bottom View



Courtesy of <http://BlackRadios.terryo.org>

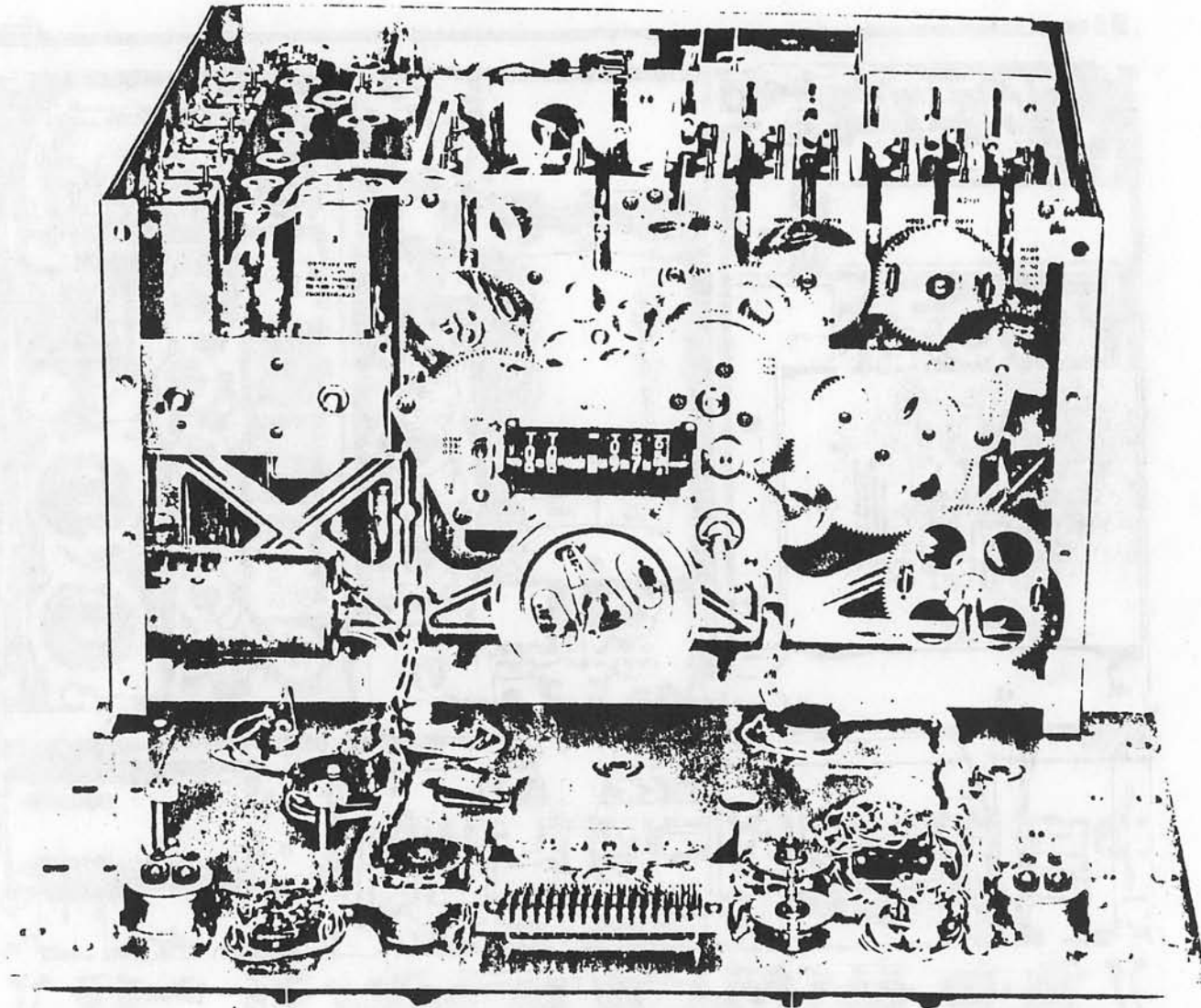

RESTRICTED

SECURITY INFORMATION - RESTRICTED

Figure 20. Radio Receiver R-390/URR, Front Panel Removed

Courtesy of <http://BlackRadios.terryo.org>

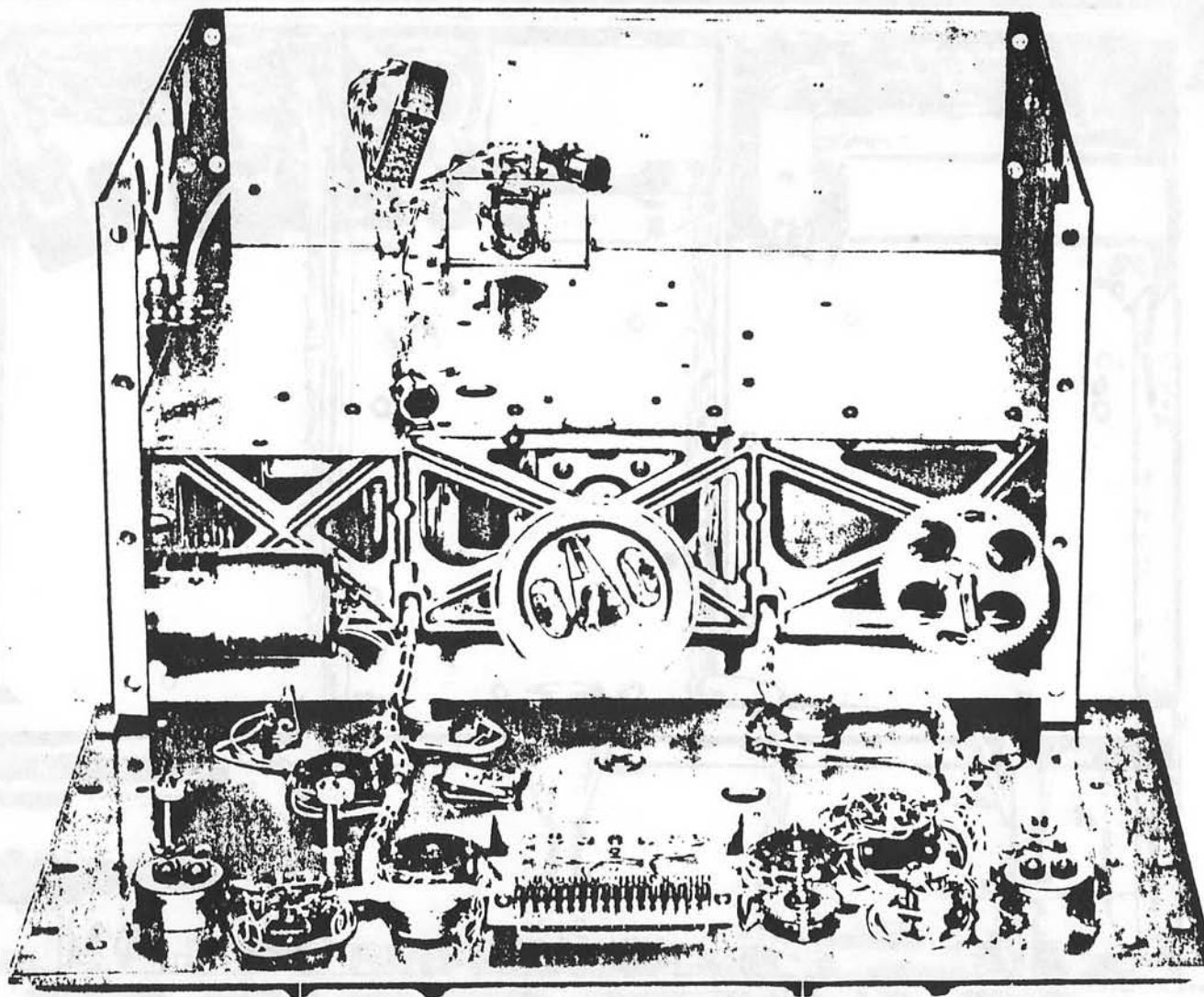

RESTRICTED

SECURITY INFORMATION - RESTRICTED

Figure 21. Radio Receiver R-390/URR, Panel and Units Removed

Courtesy of <http://BlackRadios.terryo.org>

RESTRICTED

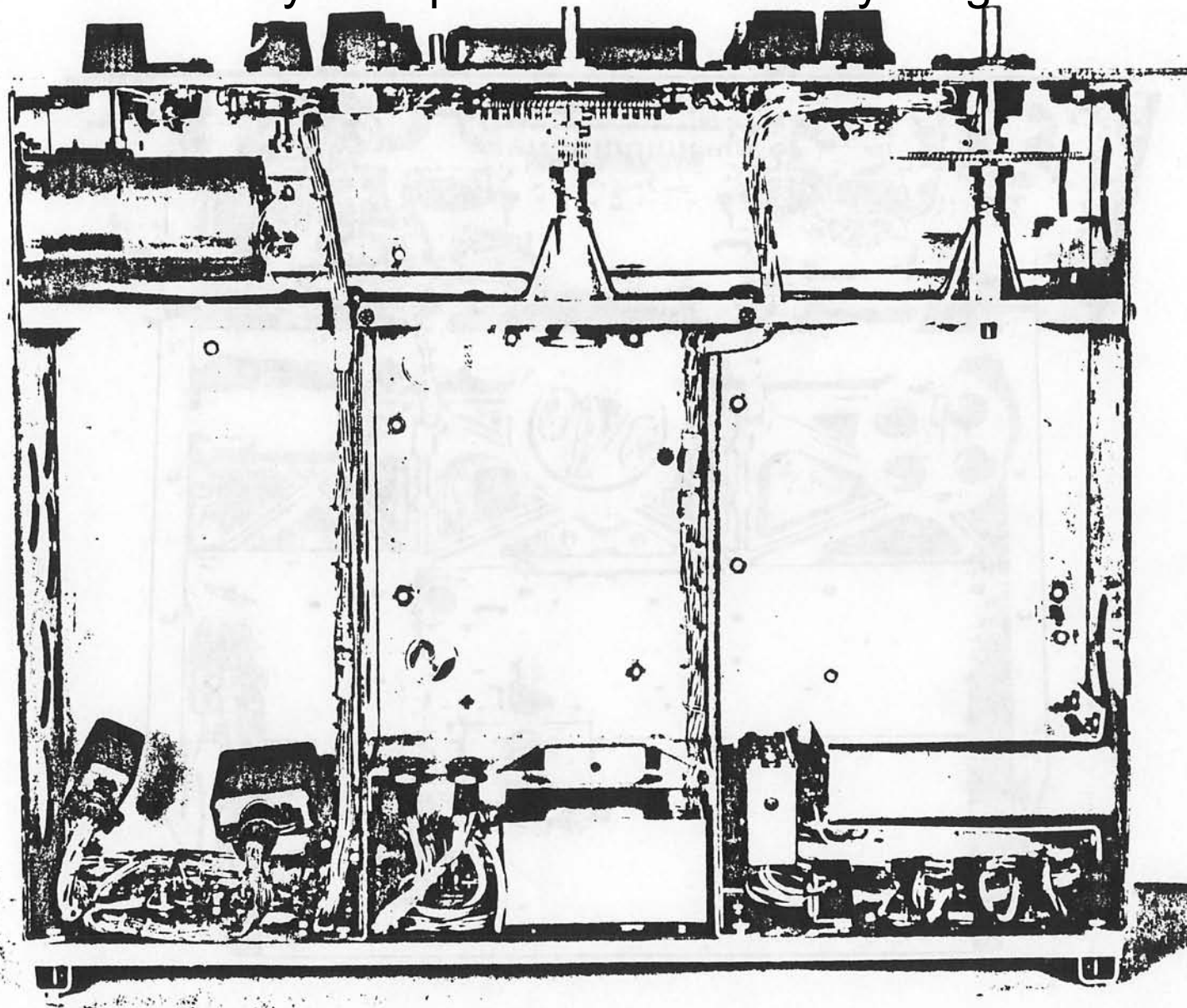

SECURITY INFORMATION - RESTRICTED

Figure 22. Radio Receiver R-390/URR, Bottom View - Units Removed

Courtesy of <http://BlackRadios.terryo.org>

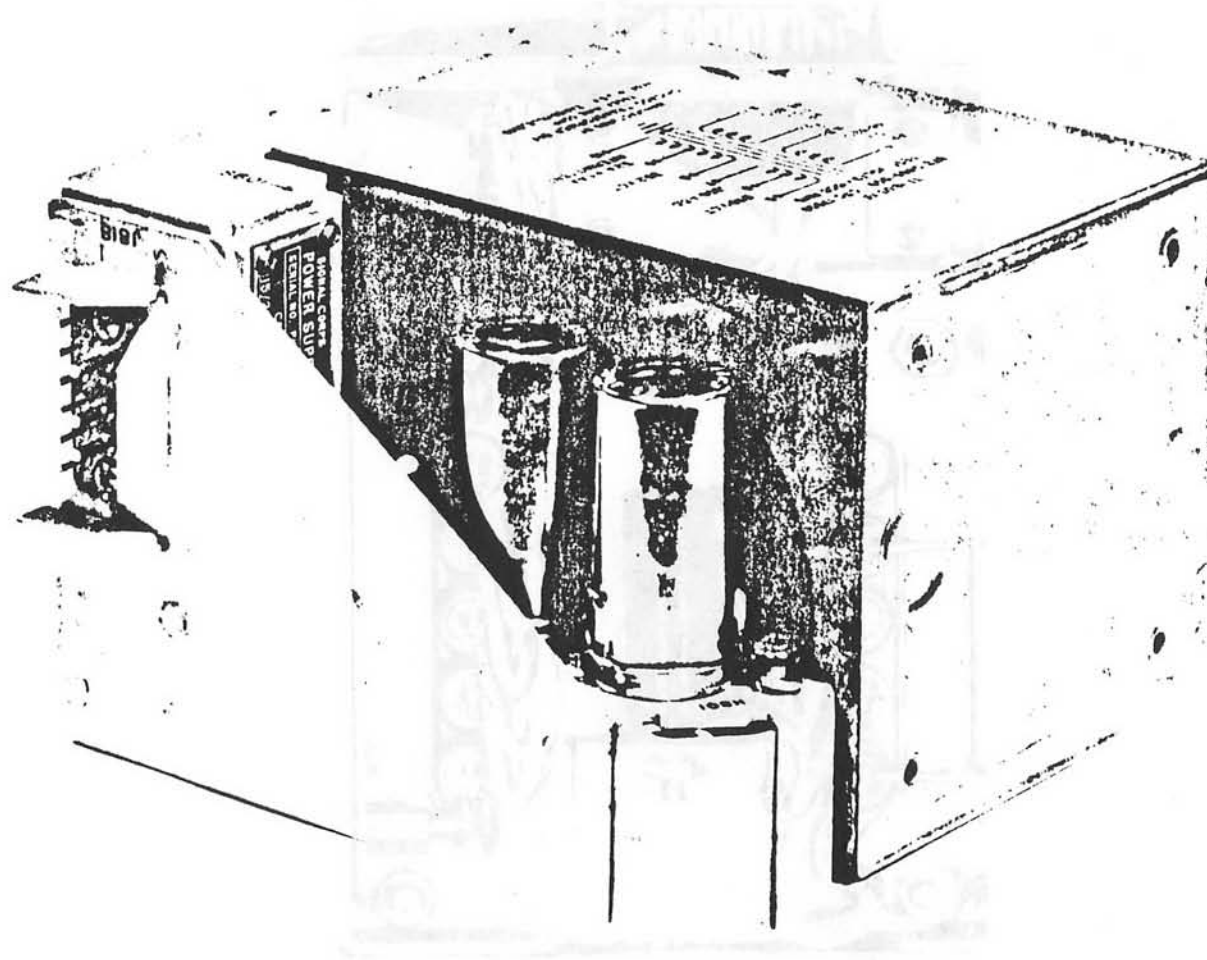

RESTRICTED

SECURITY INFORMATION - RESTRICTED

Figure 23. A-C Power Supply - Top View



Courtesy of <http://BlackRadios.terryo.org>

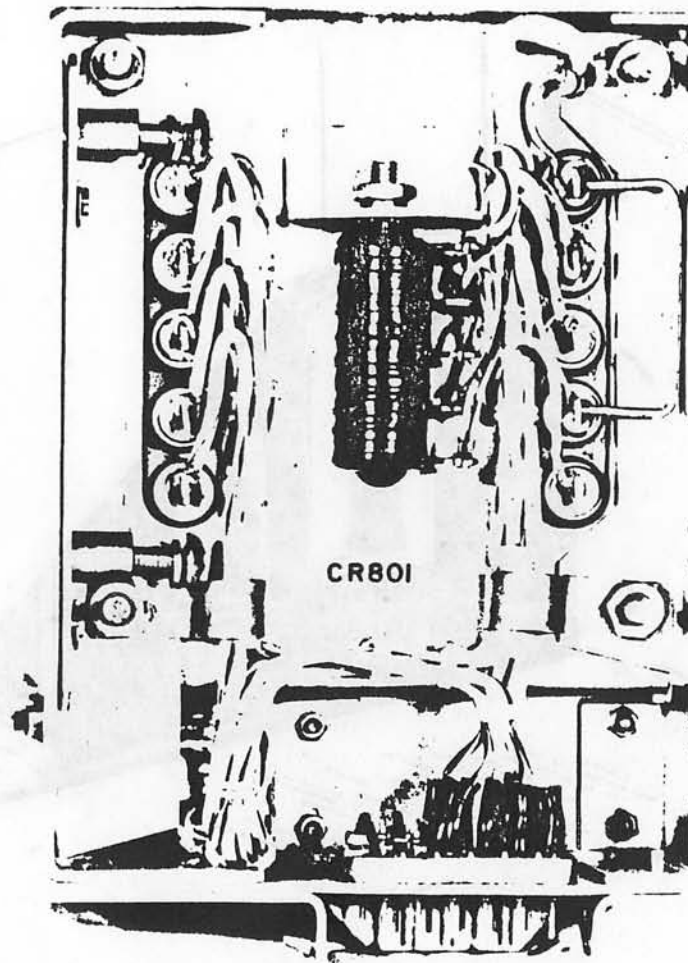
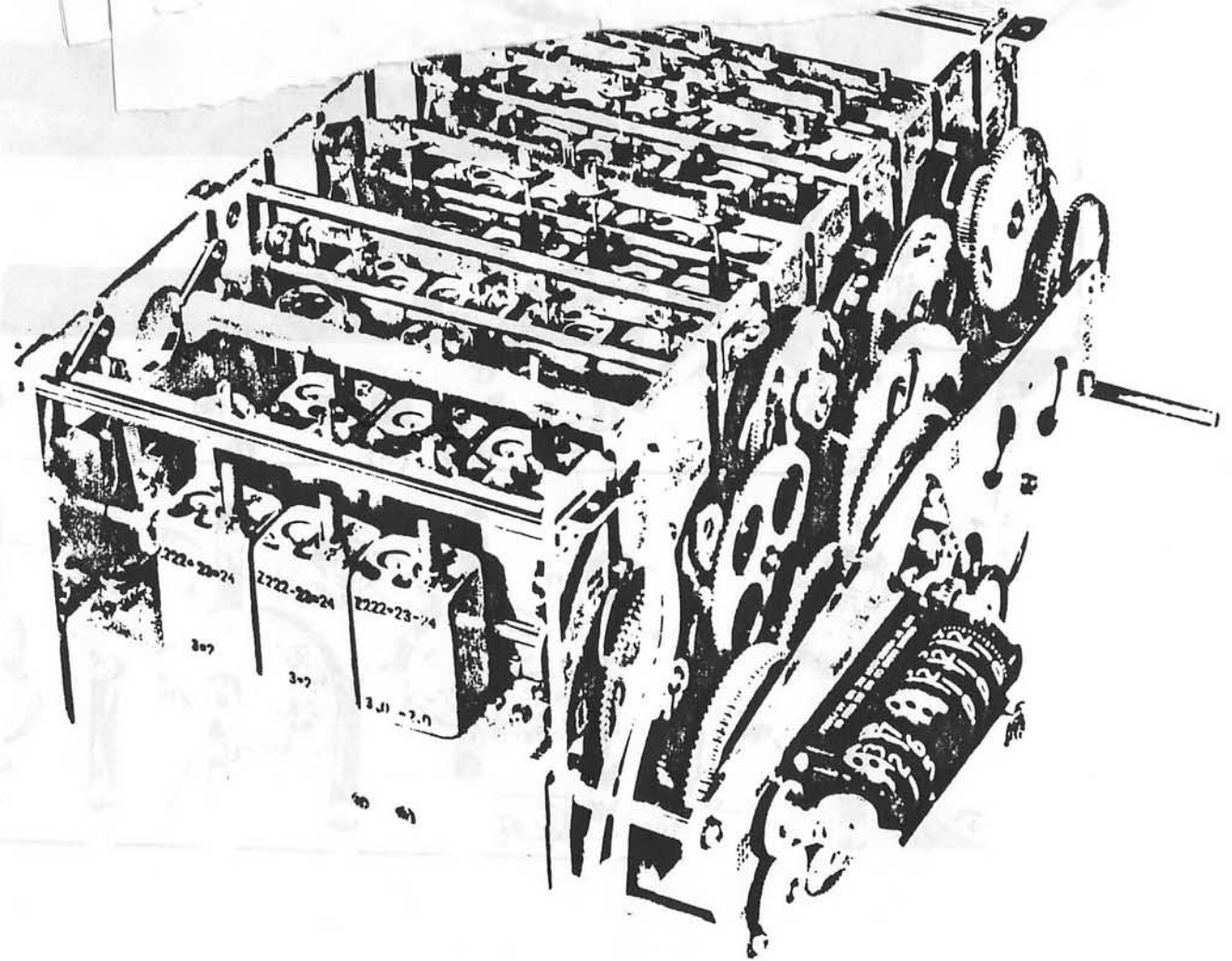

Figure 24. A-C Power Supply - Bottom View

RESTRICTED

SECURITY INFORMATION - RESTRICTED

Courtesy of <http://BlackRadios.terryo.org>



RESTRICTED

SECURITY INFORMATION - RESTRICTED

Figure 35. Radio Receiver R-390/URR R-F Unit - Oblique View

Courtesy of <http://BlackRadios.terryo.org>

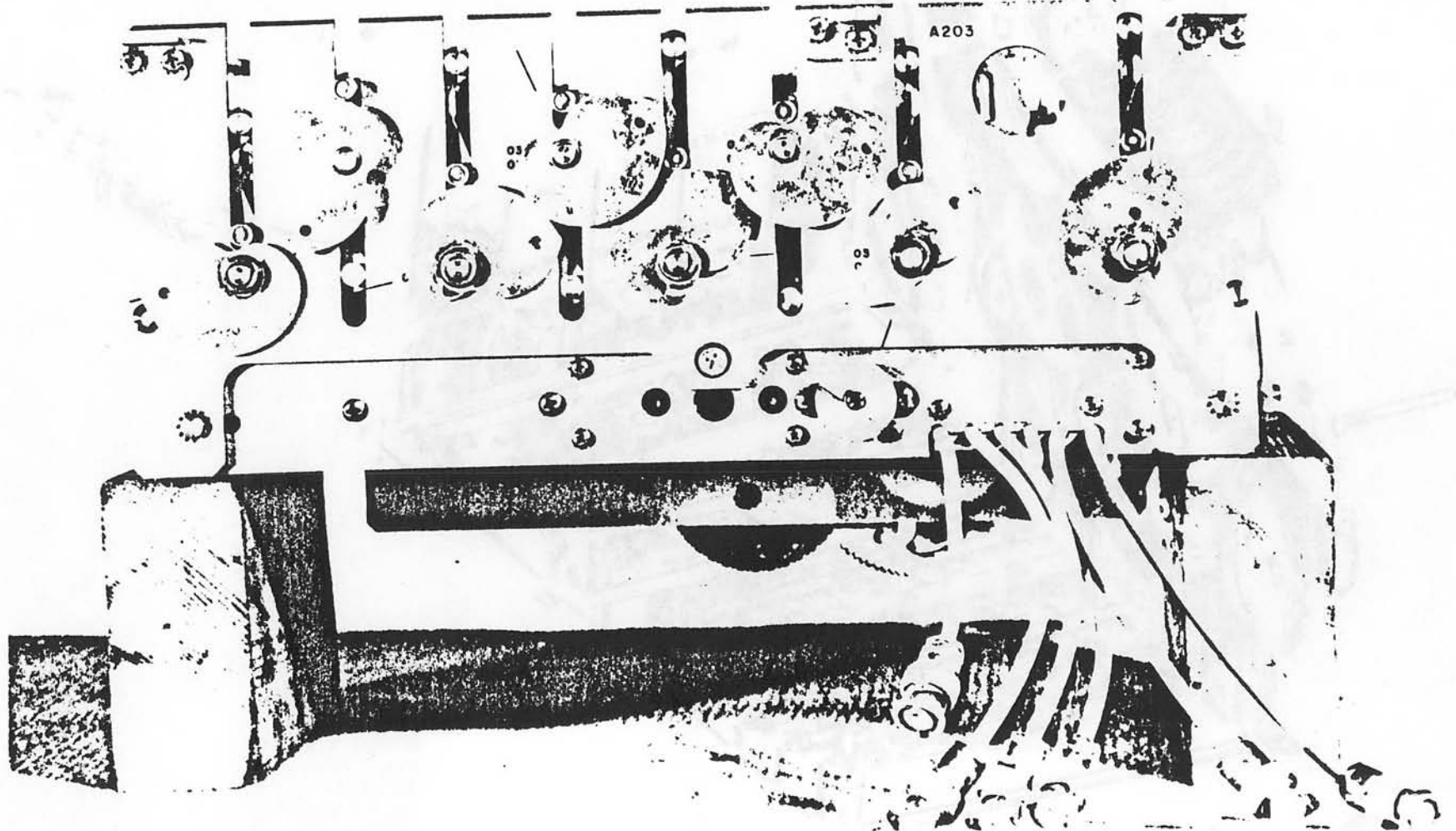

RESTRICTED

SECURITY INFORMATION - RESTRICTED

Figure 36. Radio Receiver R-390/URR R-F Unit - Rear View

Courtesy of <http://BlackRadios.terryo.org>

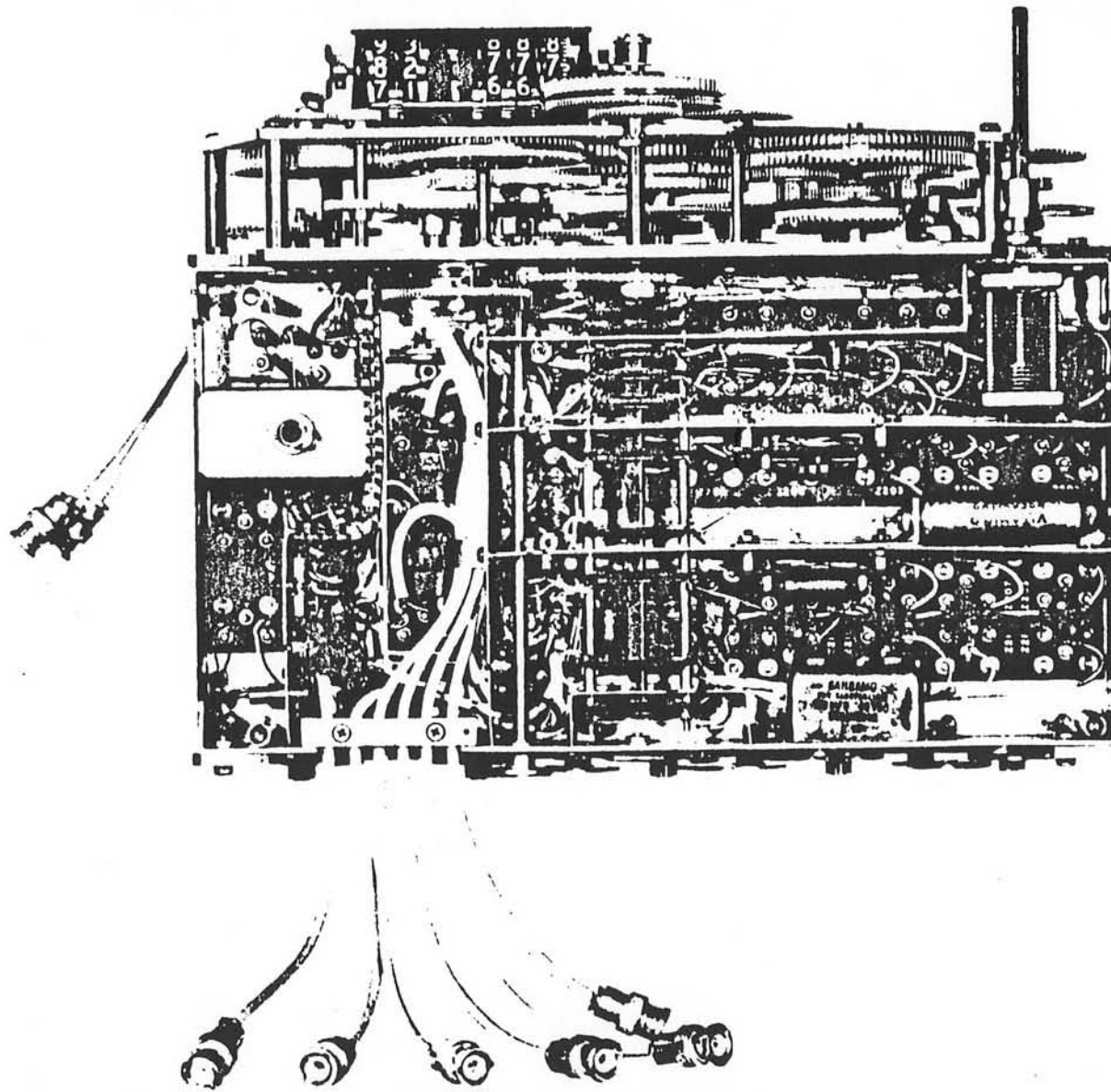

RESTRICTED

SECURITY INFORMATION - RESTRICTED

Figure 36A. Radio Receiver R-390/URR R-F Unit - Bottom View



Courtesy of <http://BlackRadios.terryo.org>

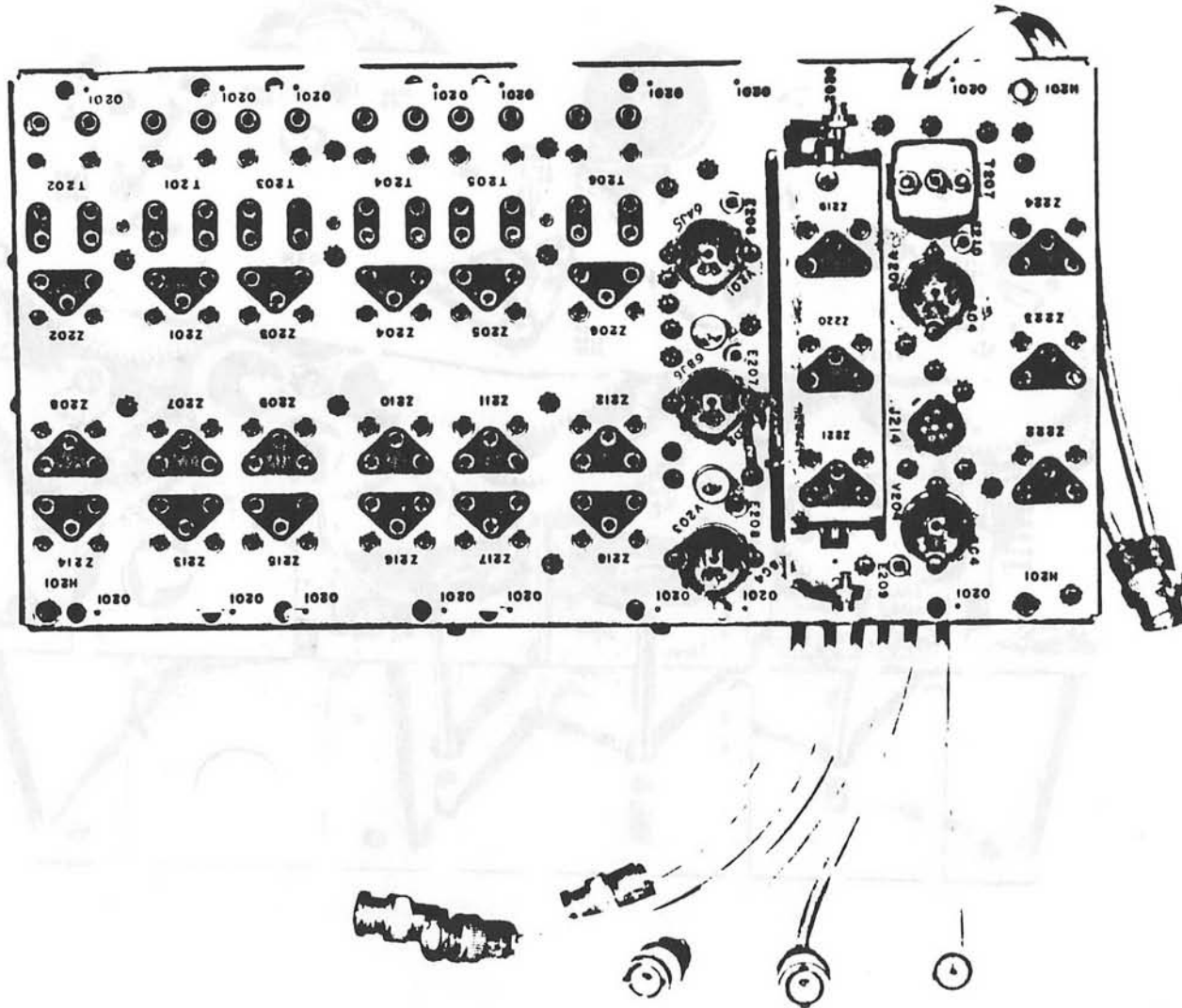

RESTRICTED

SECURITY INFORMATION - RESTRICTED

Courtesy of <http://BlackRadios.terryo.org>

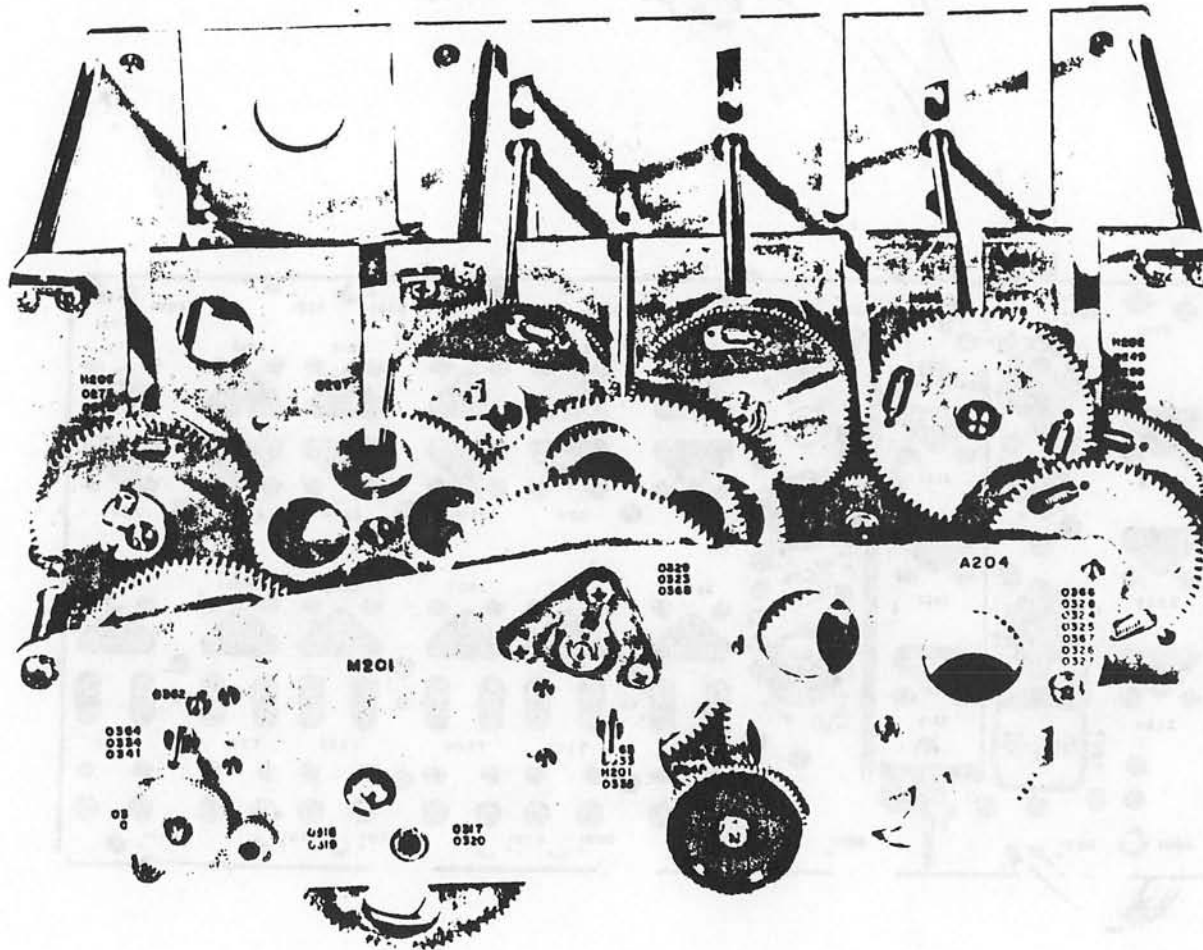

RESTRICTED

SECURITY INFORMATION - RESTRICTED

Figure 38. Radio Receiver R-390/URR R-F Gear Train

Courtesy of <http://BlackRadios.terryo.org>

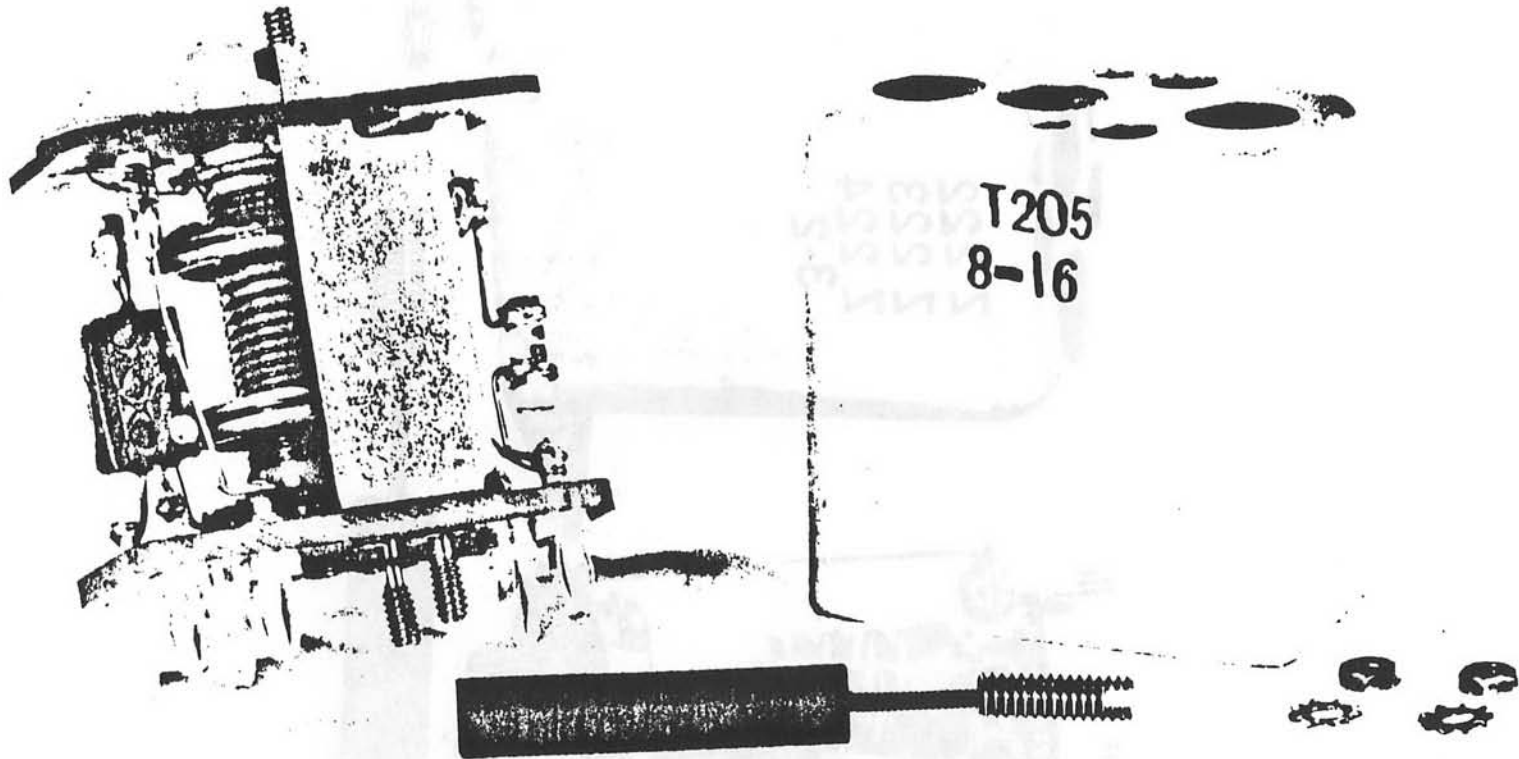

RESTRICTED

SECURITY INFORMATION - RESTRICTED

Figure 30. Radio Receiver R-390/IRR Antenna Coil

Courtesy of <http://BlackRadios.terryo.org>

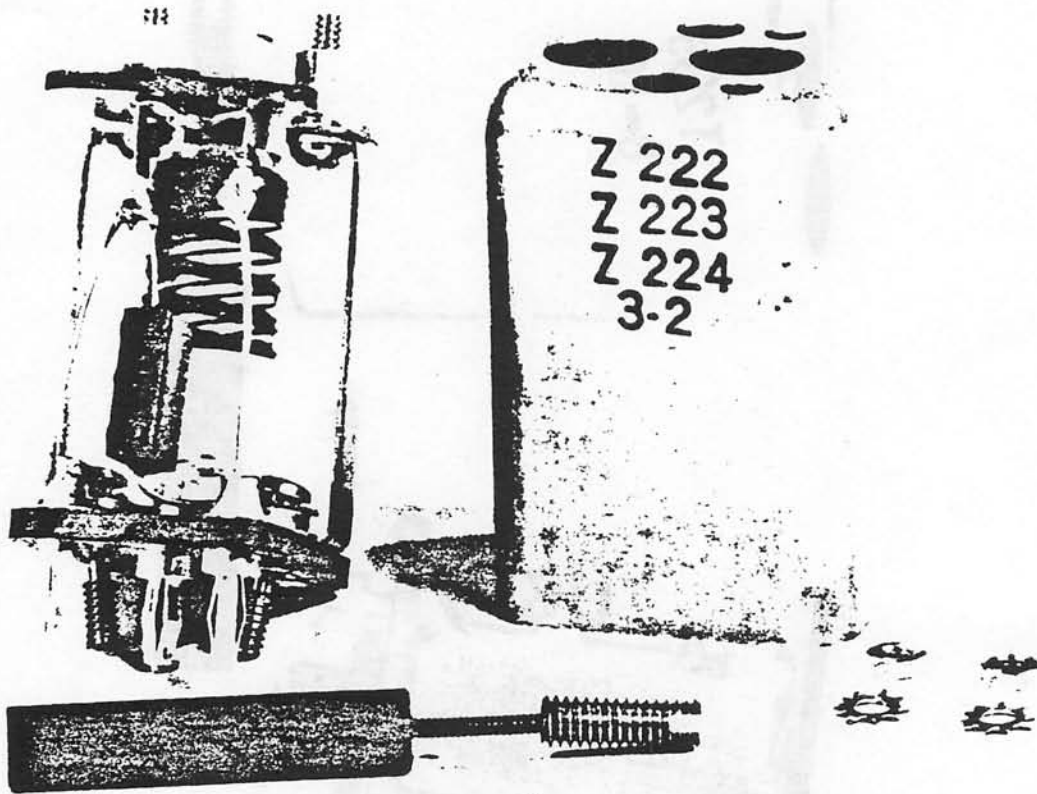
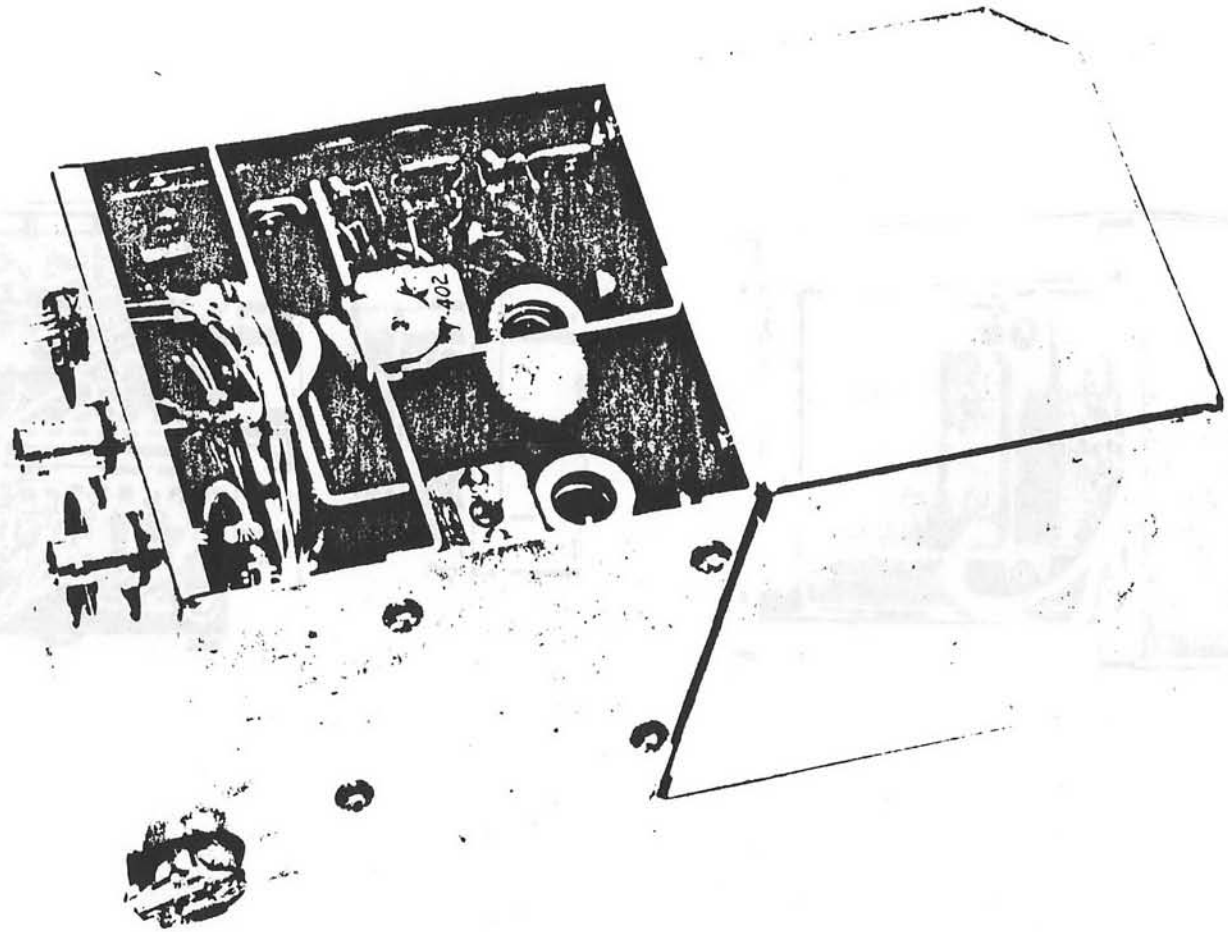

Figure 40. Radio Receiver R-390/URR R-F Coil



Courtesy of <http://BlackRadios.terryo.org>



RESTRICTED

SECURITY INFORMATION - RESTRICTED

Courtesy of <http://BlackRadios.terryo.org>

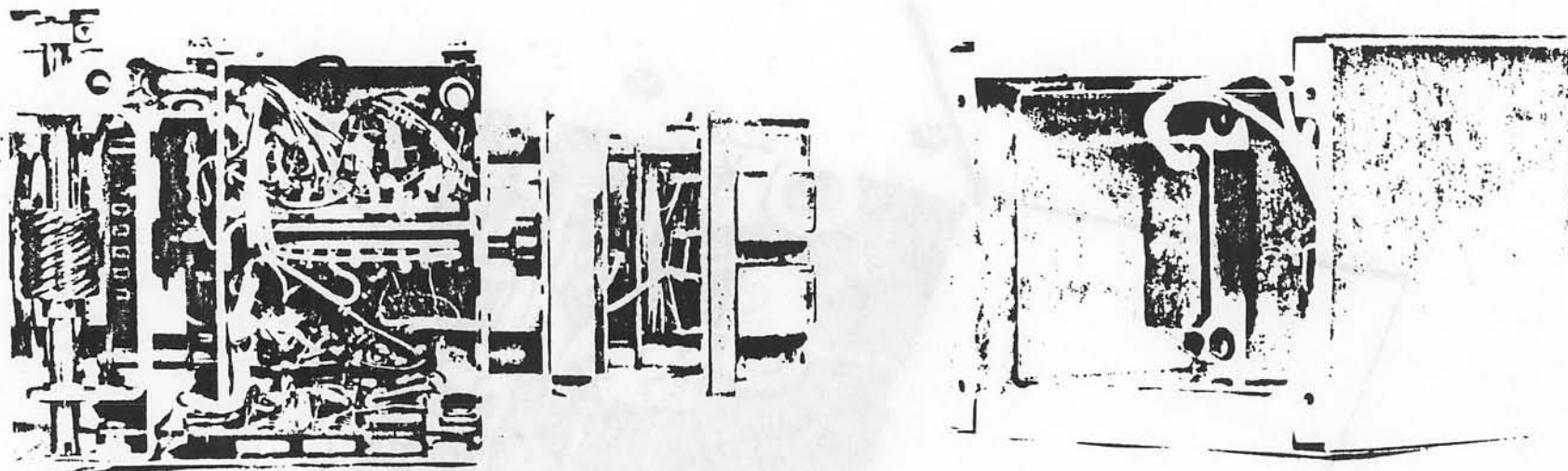

RESTRICTED

SECURITY INFORMATION - RESTRICTED

Figure 42. Crystal Oscillator, Oven Removed

Courtesy of <http://BlackRadios.terryo.org>

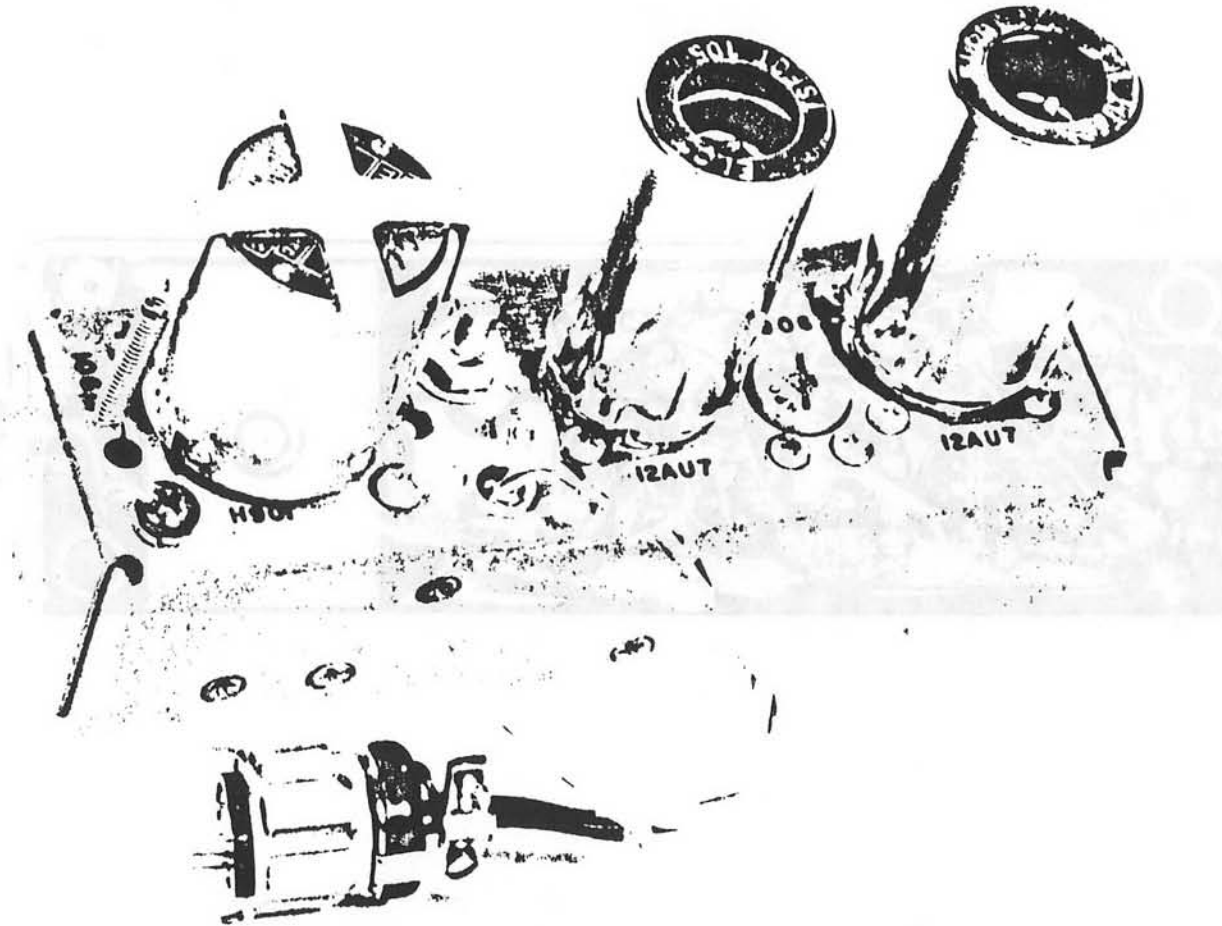

RESTRICTED

SECURITY INFORMATION - RESTRICTED

Figure 43. Calibrator Unit - Top View

Courtesy of <http://BlackRadios.terryo.org>

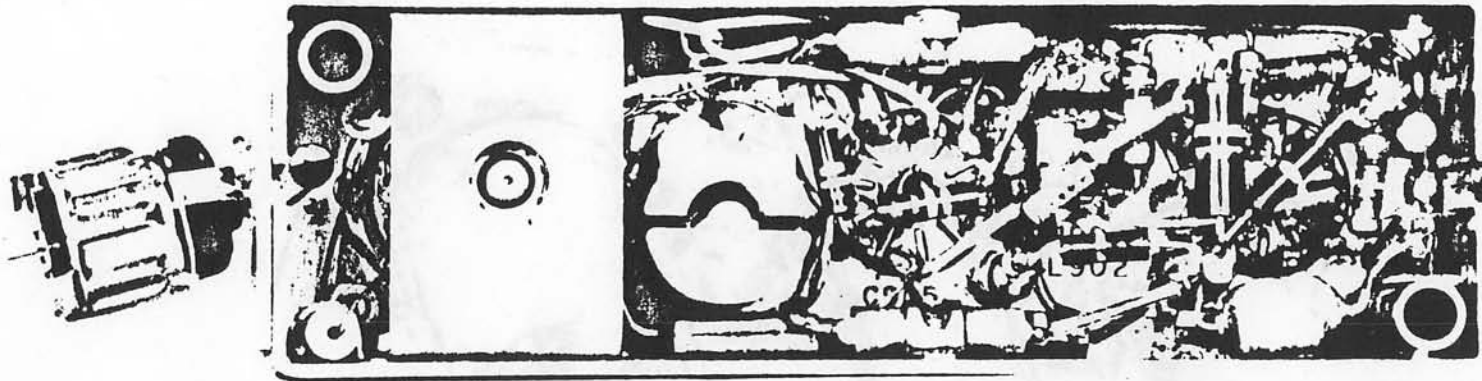

RESTRICTED

SECURITY INFORMATION - RESTRICTED

Figure 44. Calibrator Unit - Bottom View



Courtesy of <http://BlackRadios.terryo.org>

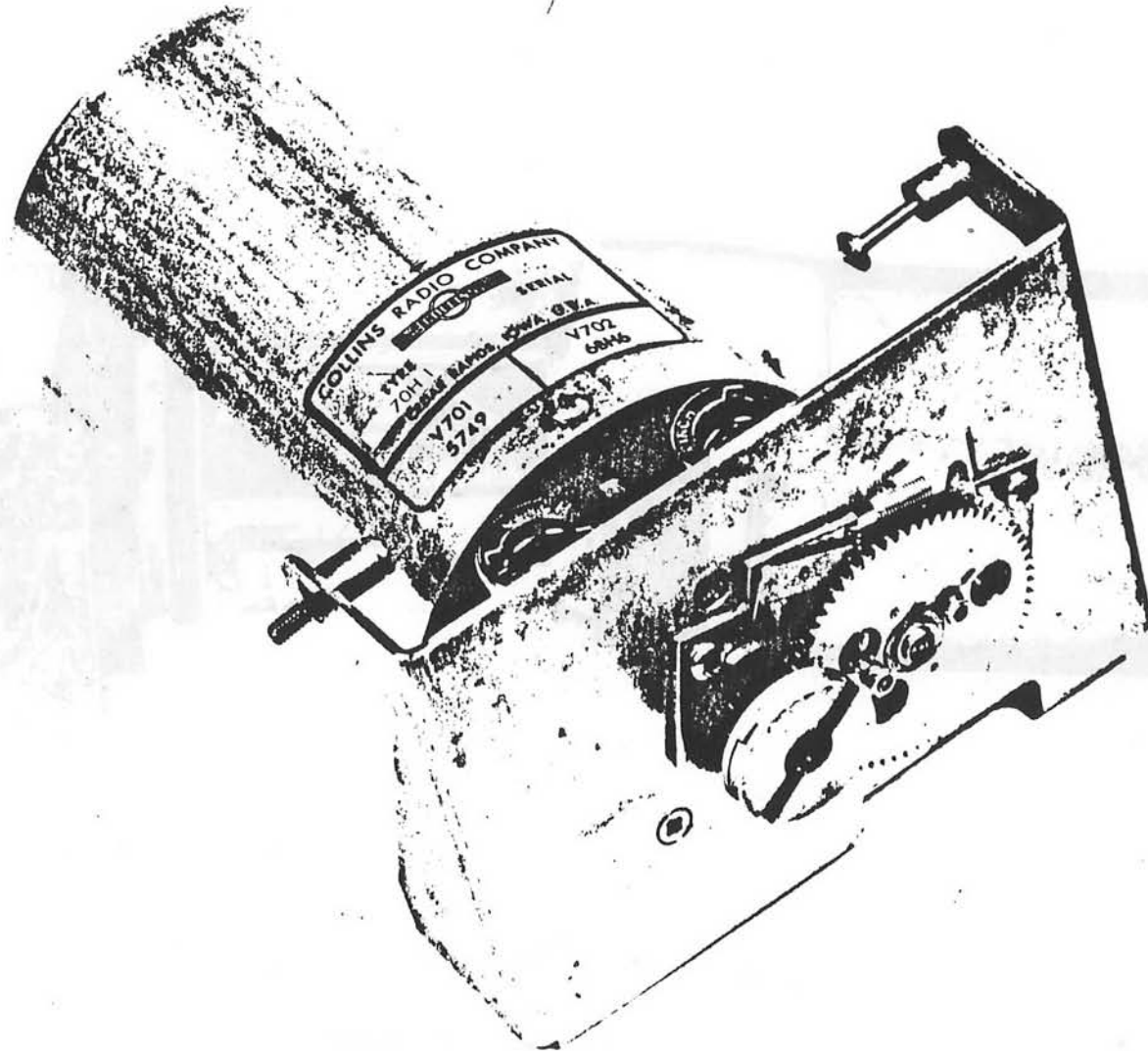

RESTRICTED

SECURITY INFORMATION - RESTRICTED

Figure 45 Radio Receiver R-380/11RR VFO

Courtesy of <http://BlackRadios.terryo.org>

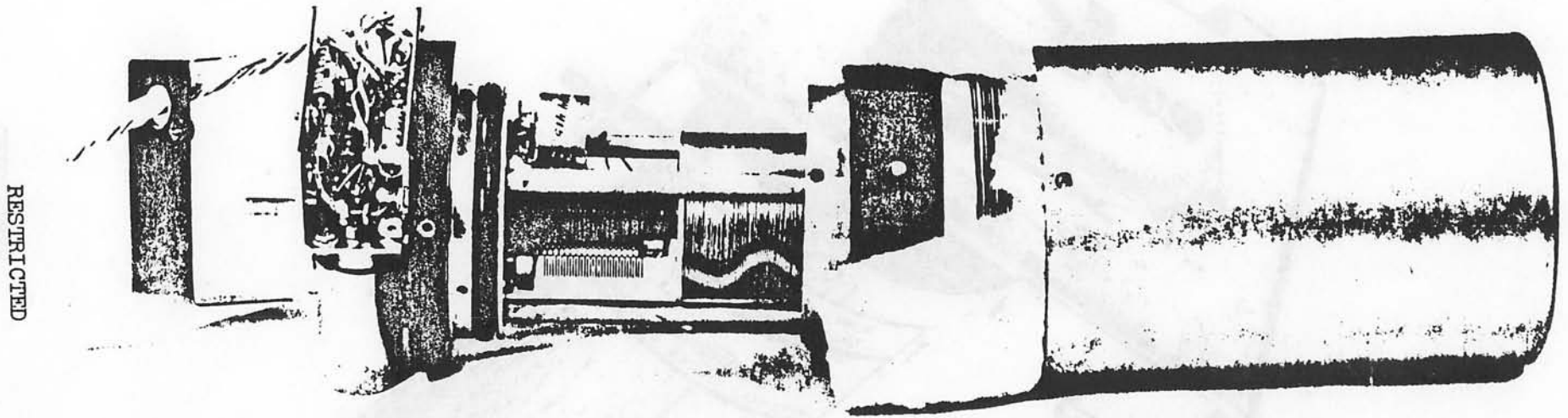
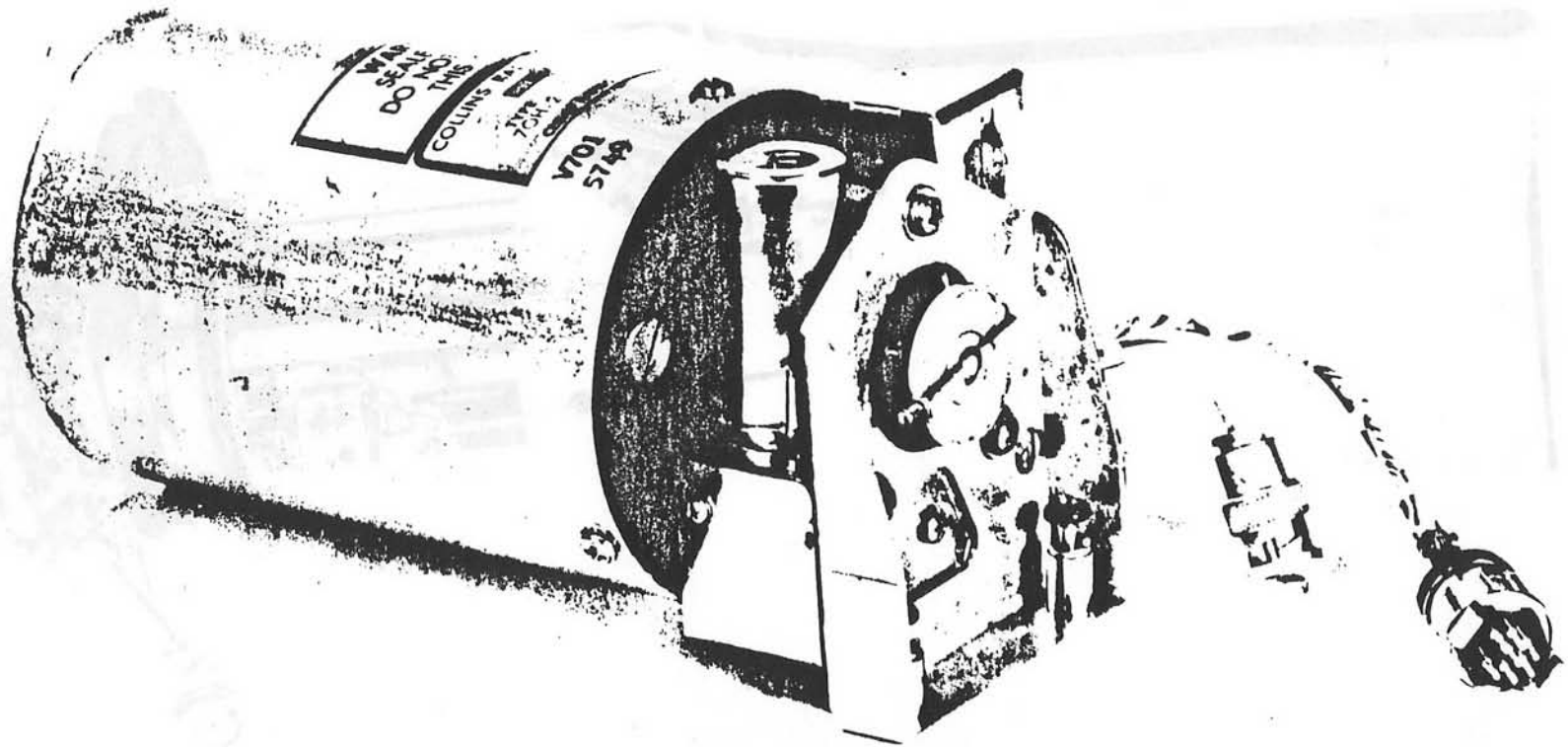

Figure 46. Radio Receiver R-389/URR VFO - Cover Removed

RESTRICTED

SECURITY INFORMATION - RESTRICTED

Courtesy of <http://BlackRadios.terryo.org>



RESTRICTED

SECURITY INFORMATION - RESTRICTED

Figure 47. Radio Receiver R-390/URR VFO

Courtesy of <http://BlackRadios.terryo.org>

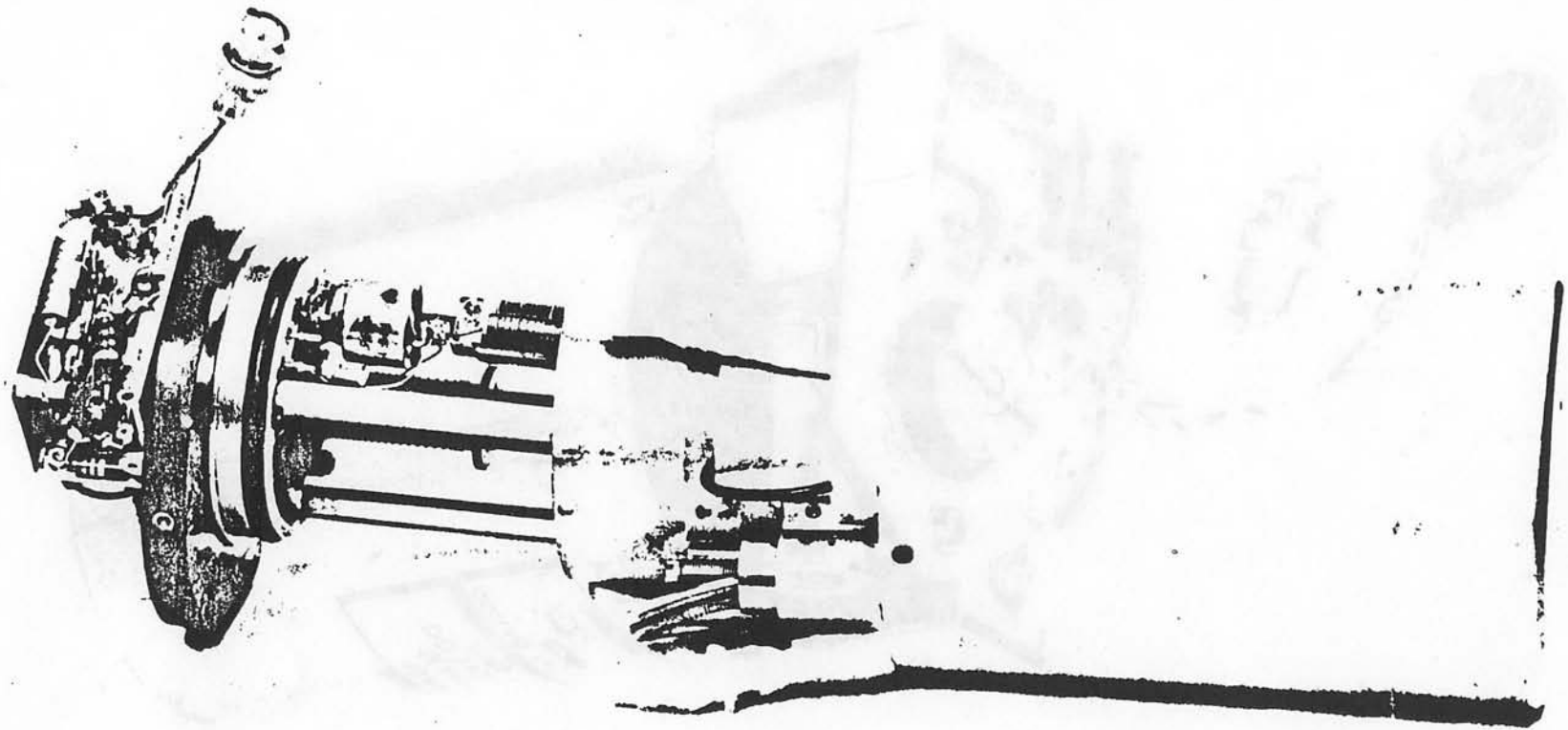

RESTRICTED

SECURITY INFORMATION - RESTRICTED

Figure 48. Radio Receiver R-390/URR VFO - Cover Removed



Courtesy of <http://BlackRadios.terryo.org>

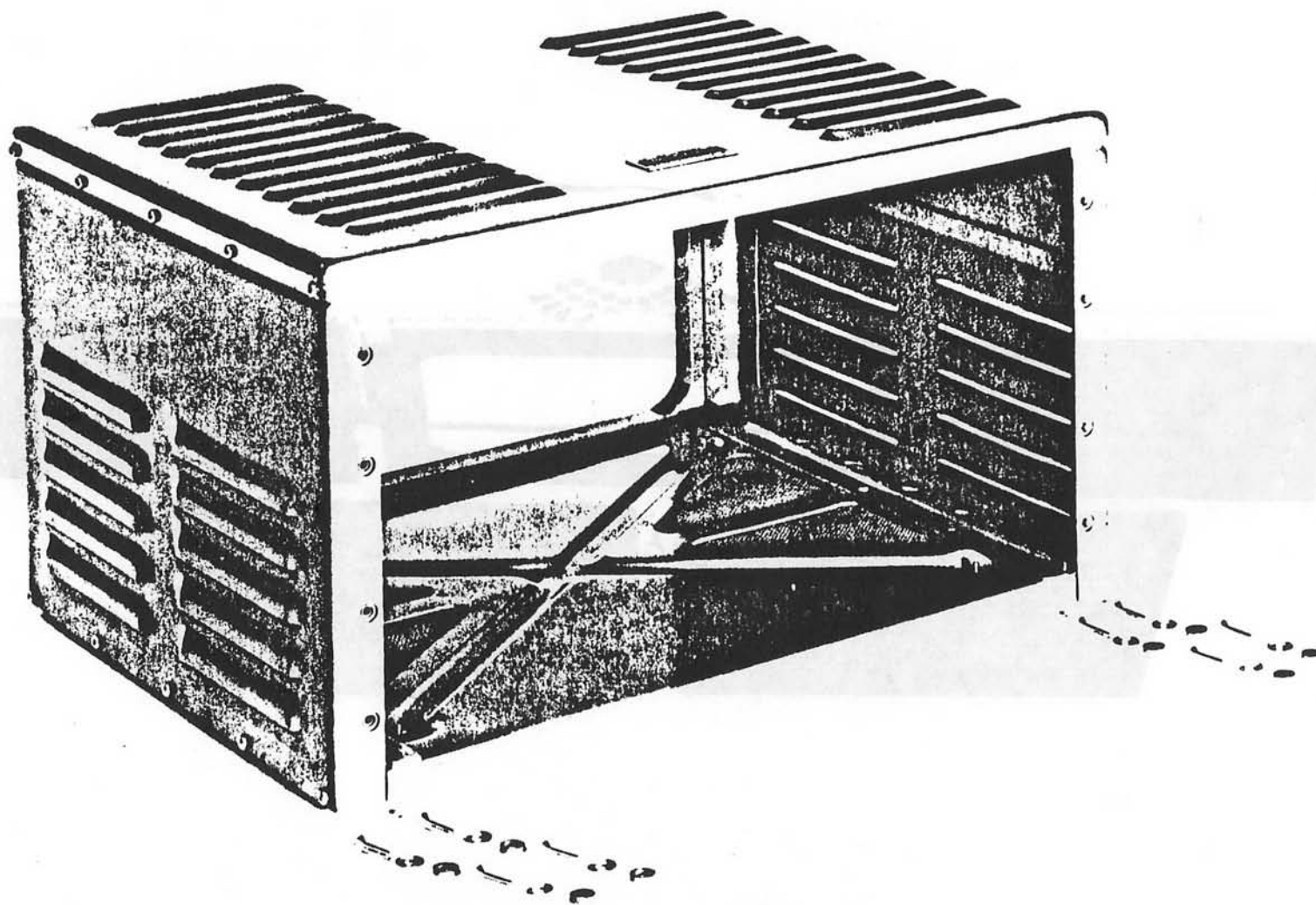

Figure 49. Table Cabinet

RESTRICTED

SECURITY INFORMATION - RESTRICTED

Courtesy of <http://BlackRadios.terryo.org>

RESTRICTED

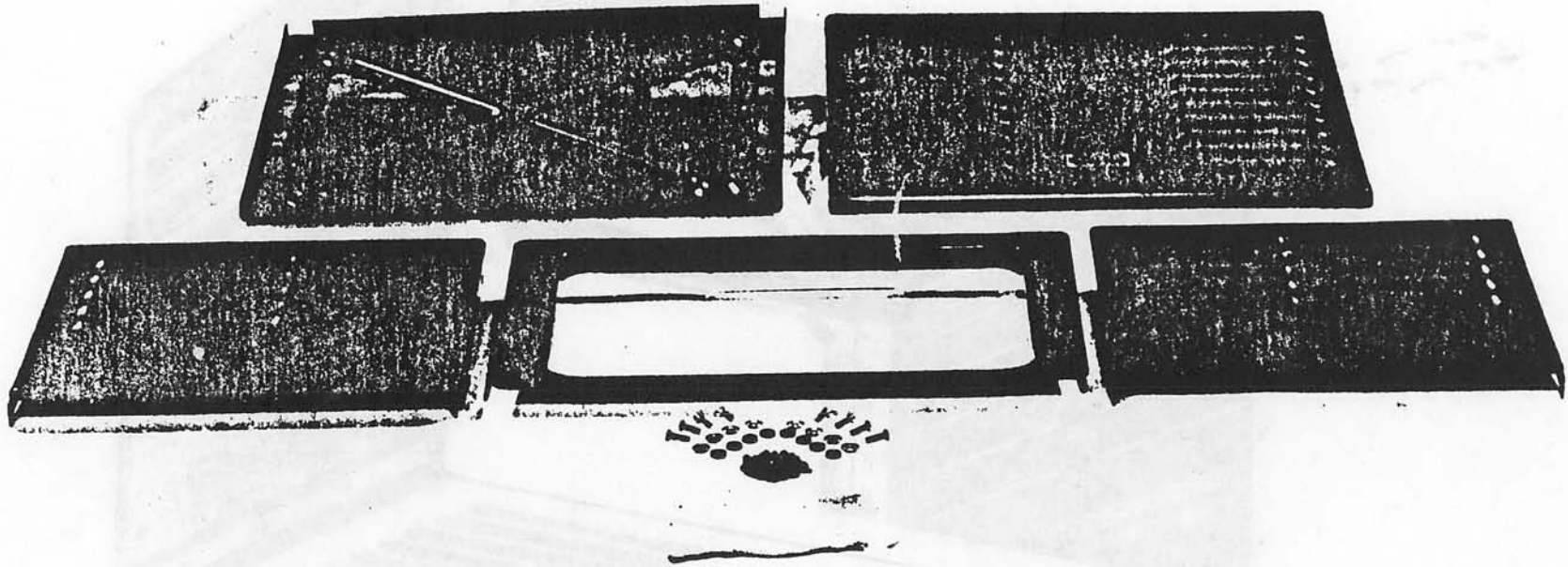

SECURITY INFORMATION - RESTRICTED

Figure 50. Table Cabinet - Collapsed



Courtesy of <http://BlackRadios.terryo.org>

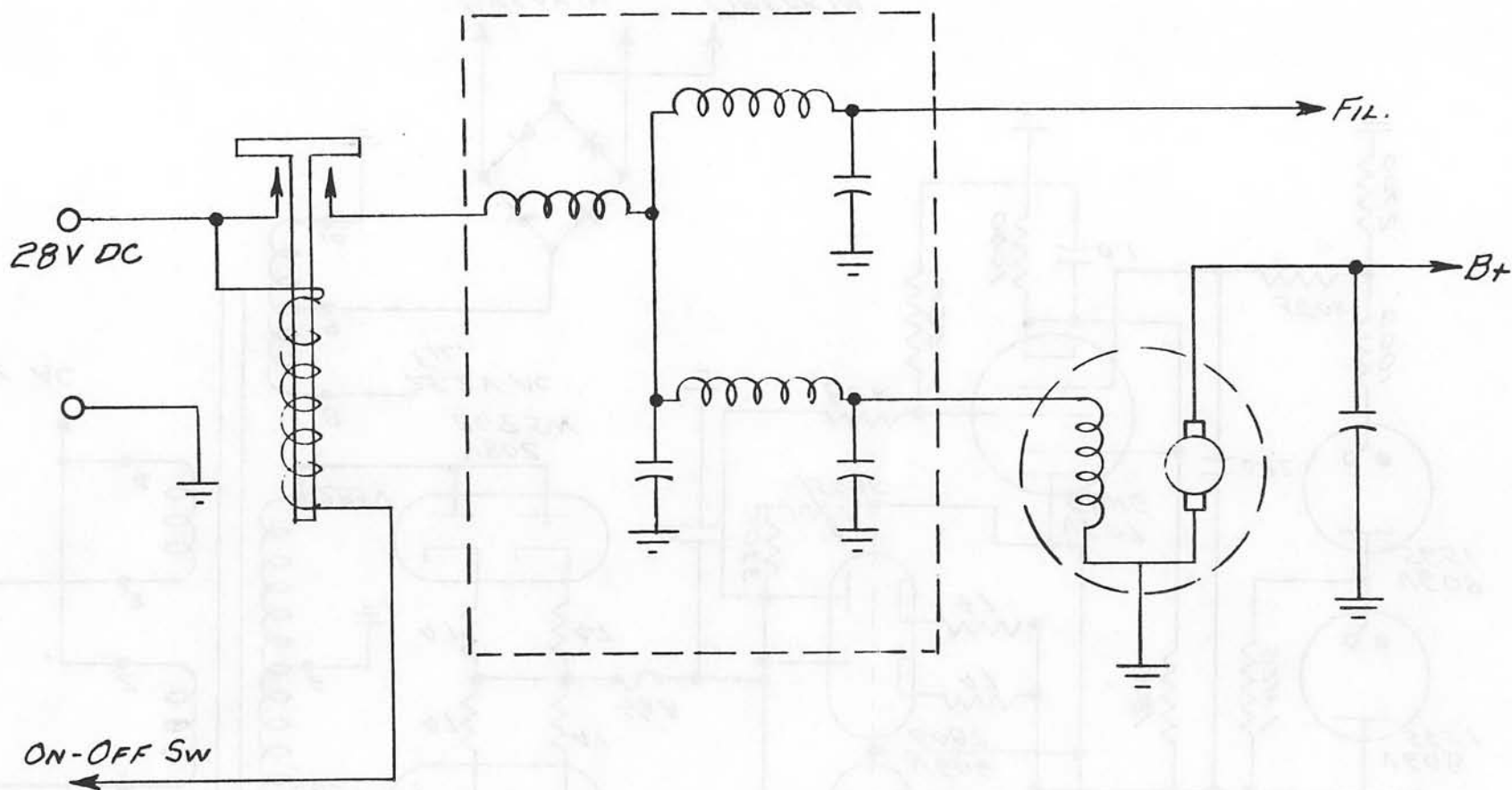

Figure 52. Dynamotor Filter Circuit

RESTRICTED

SECURITY INFORMATION - RESTRICTED



Courtesy of <http://BlackRadios.terryo.org>

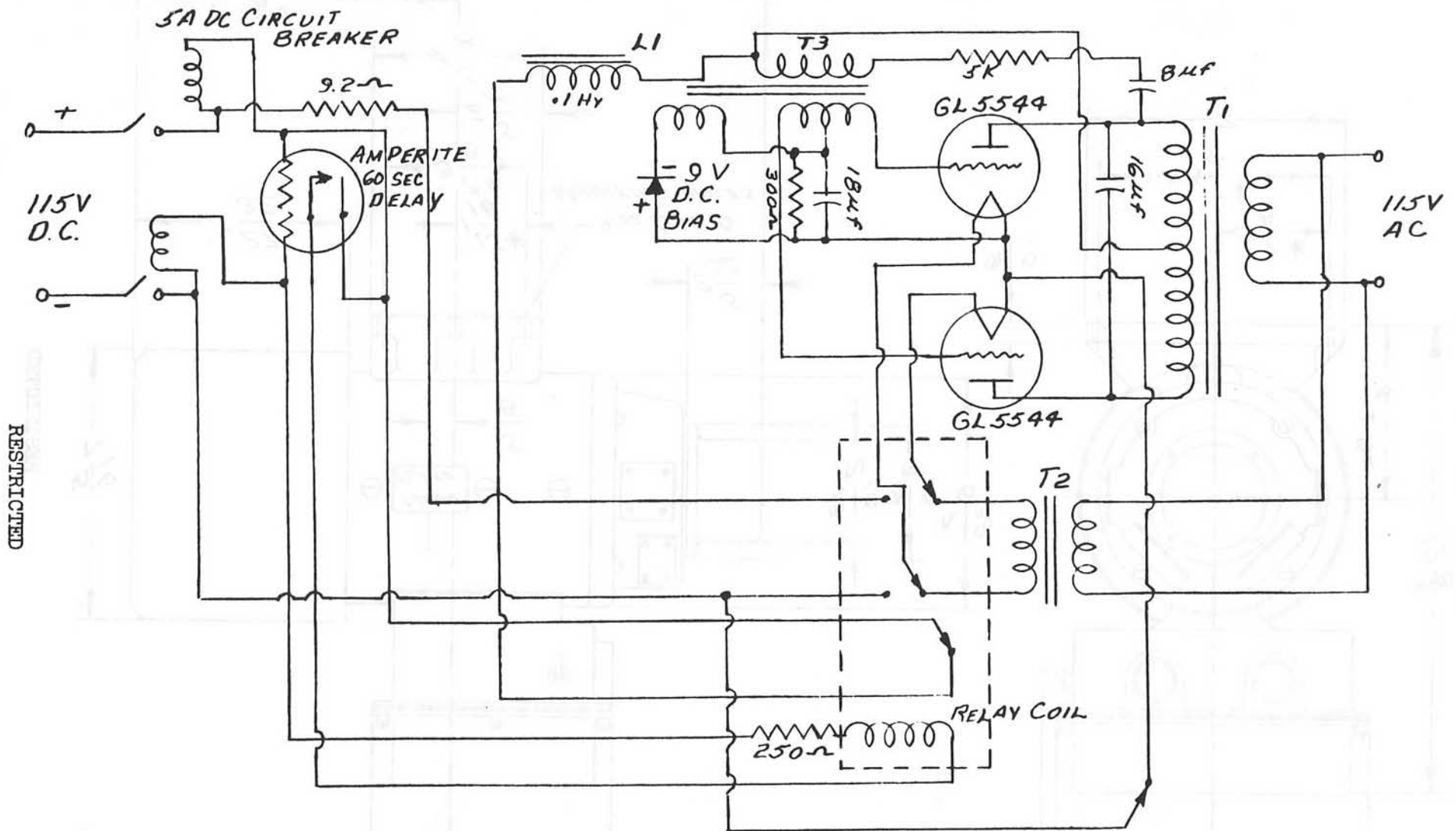

RESTRICTED

SECURITY INFORMATION - RESTRICTED

Figure 53. 115 Volt DC Inverter

Courtesy of <http://BlackRadios.terryo.org>

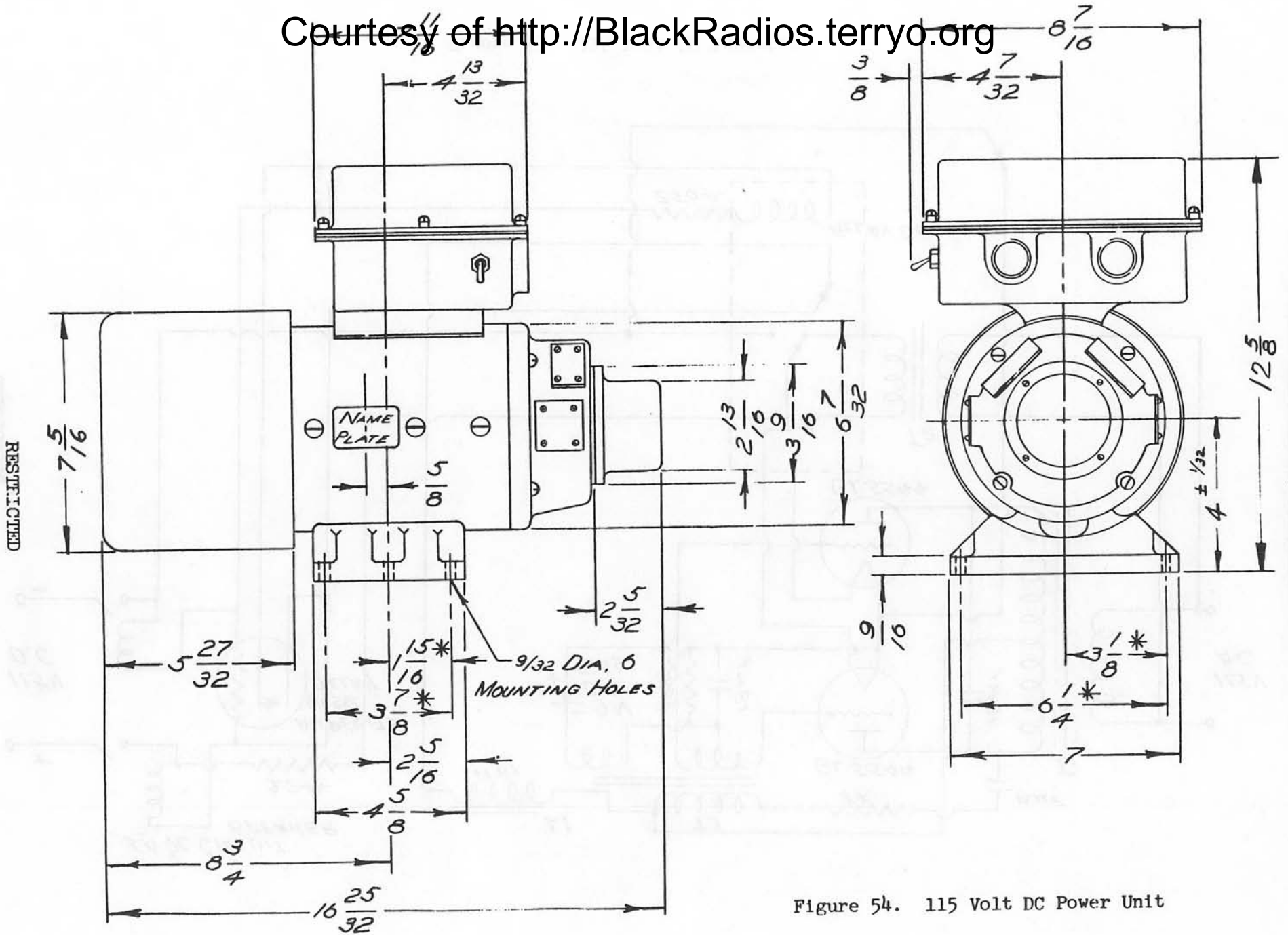

RESTRICTED

SECURITY INFORMATION - RESTRICTED

Figure 54. 115 Volt DC Power Unit

Courtesy of <http://BlackRadios.terryo.org>

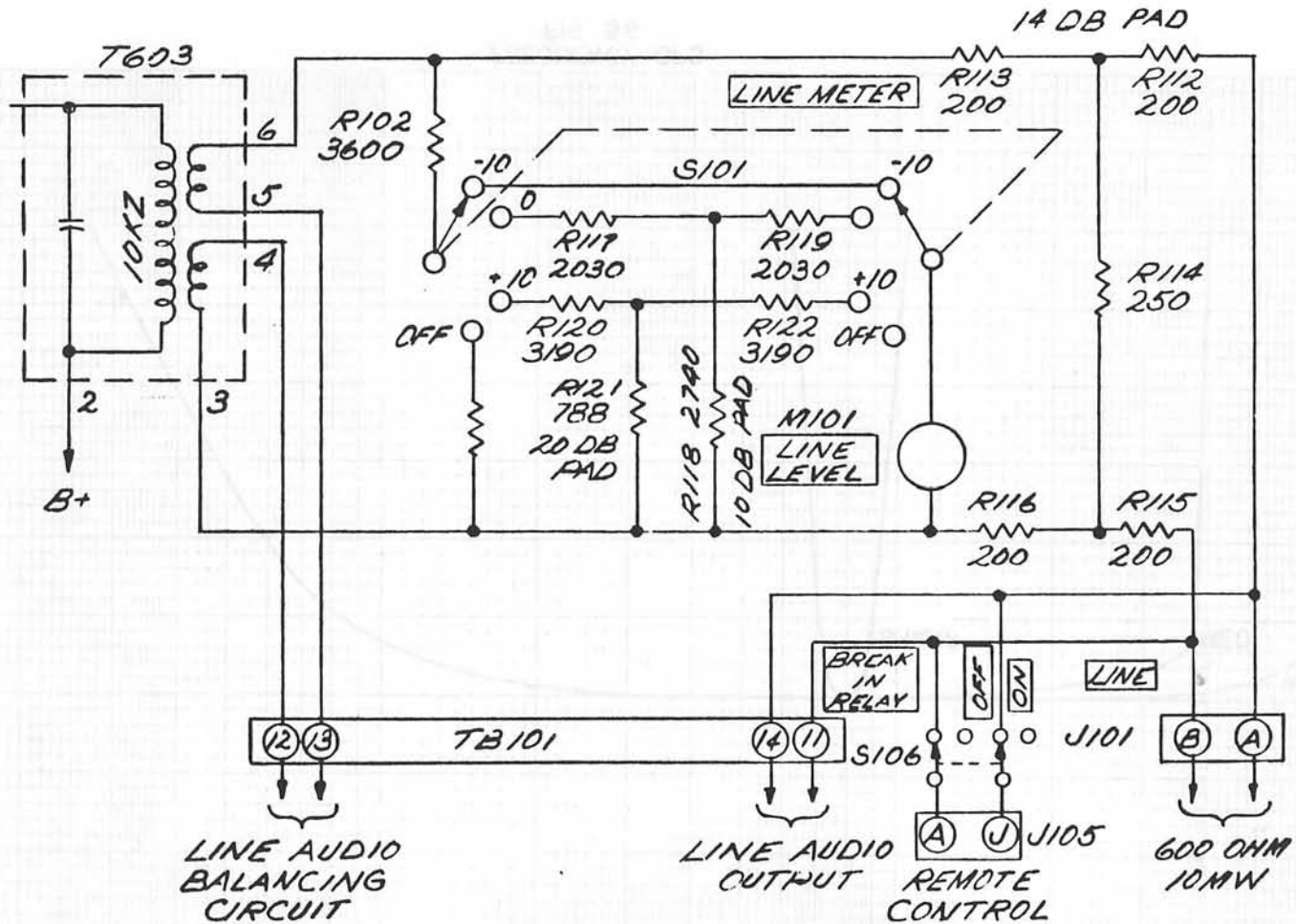

Figure 55. Line Audio Output Circuits,  
Simplified Schematic Diagram

RESTRICTED

SECURITY INFORMATION - RESTRICTED

Courtesy of <http://BlackRadios.terryo.org>

TYPICAL OVERALL AUDIO RESPONSE OF R-389 AND R-390 RECEIVERS

IF BANDWIDTH 15 KC

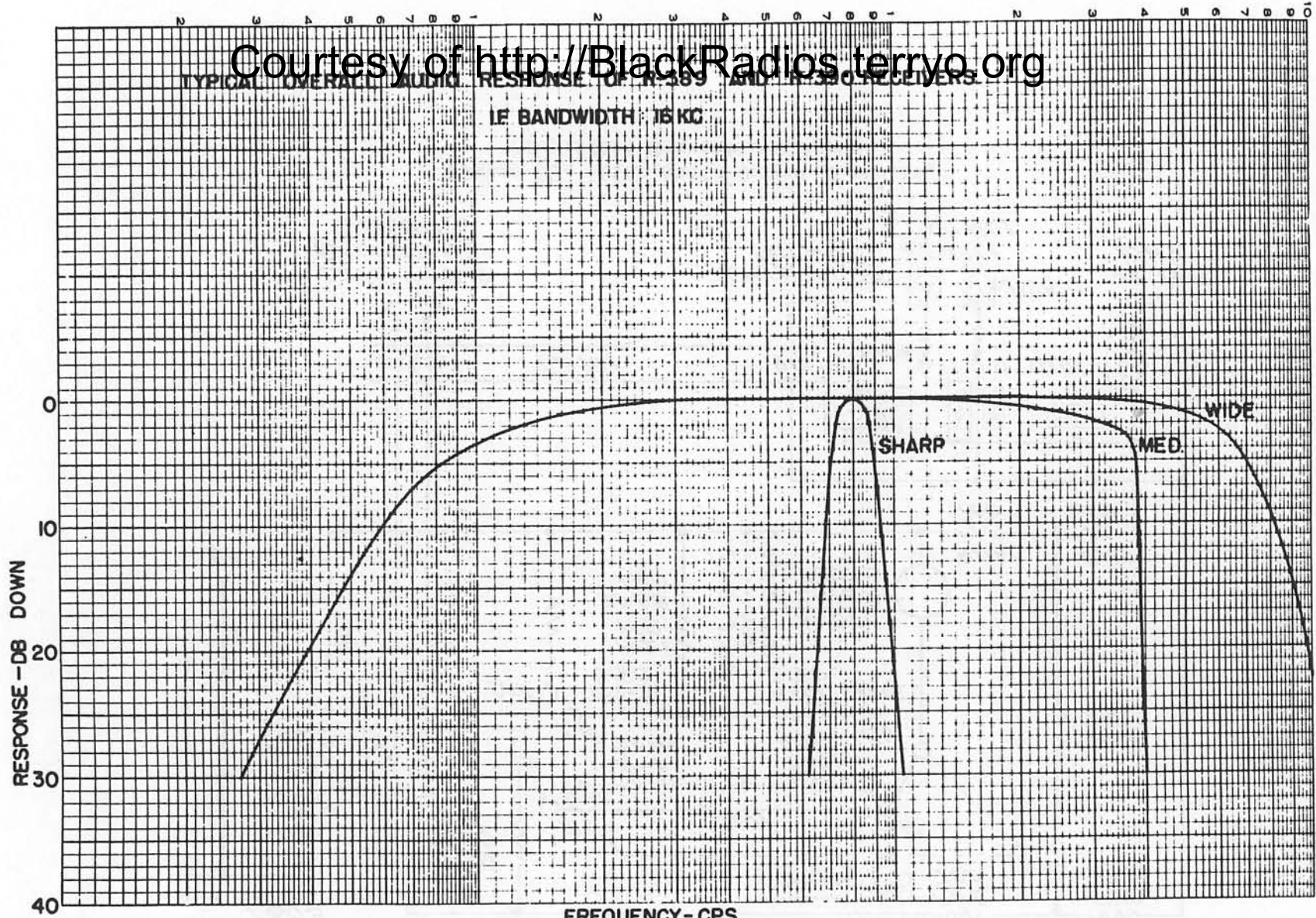

FREQUENCY - CPS  
FIG. 56

RESTRICTED

SECURITY INFORMATION - RESTRICTED



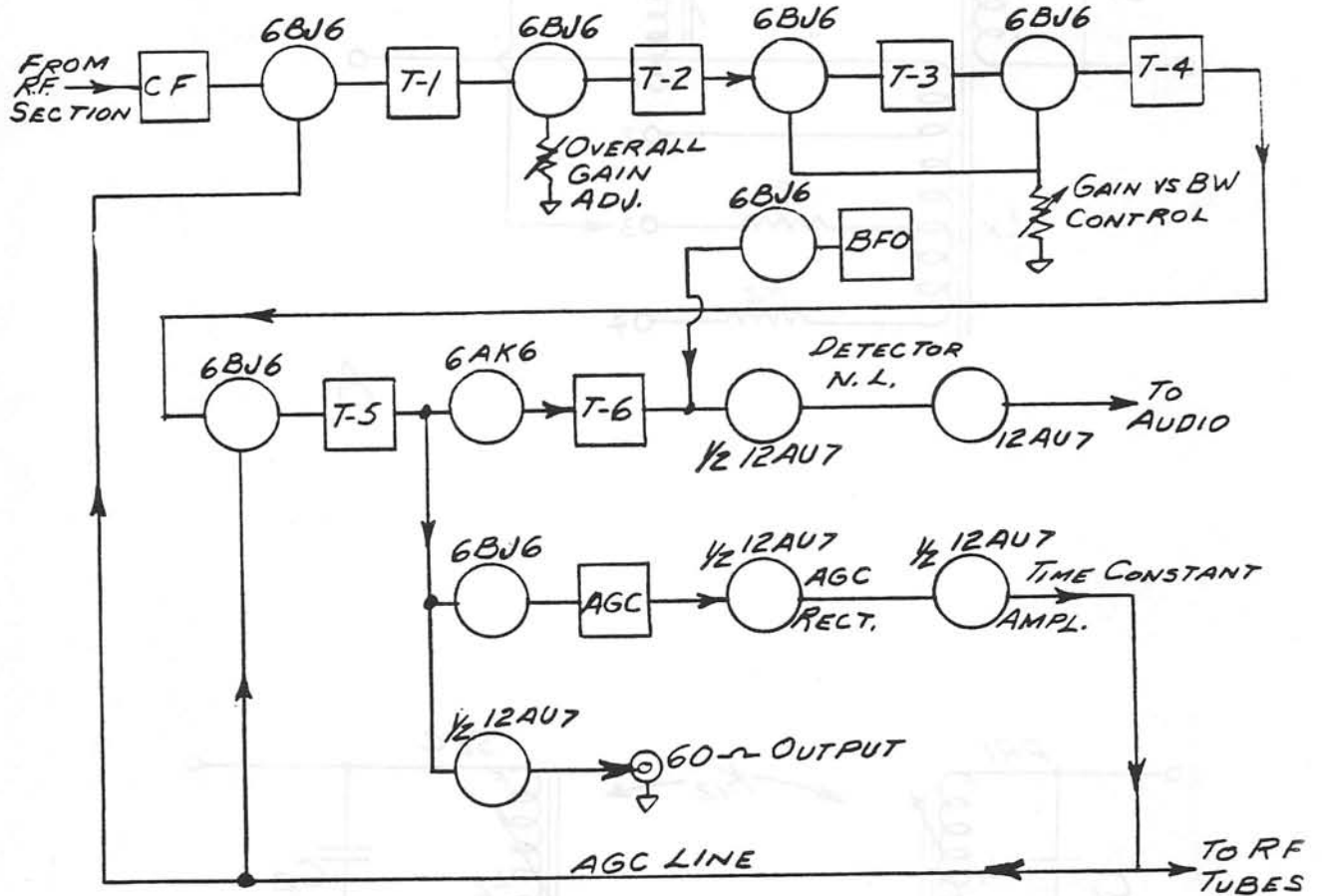

Figure 57. I-F Unit Block Diagram

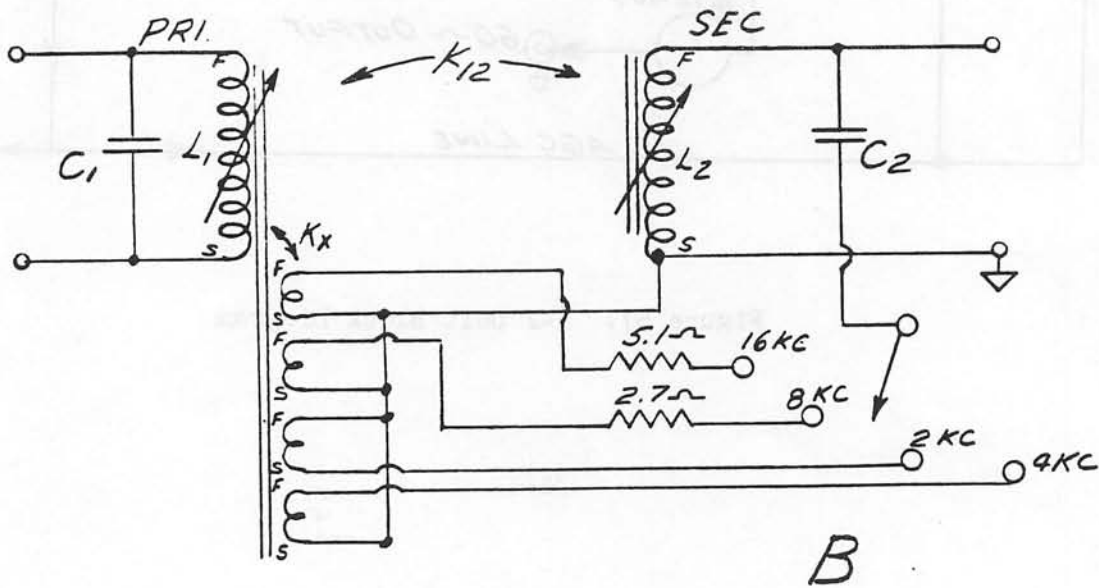
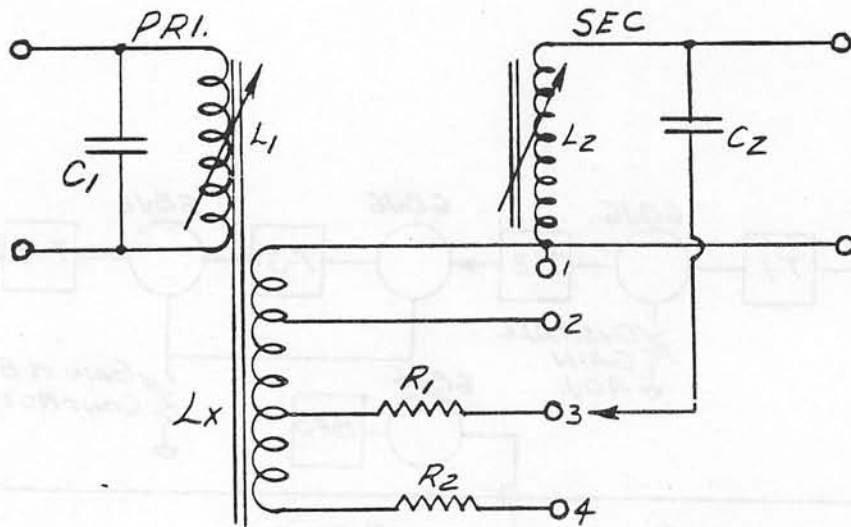

Figure 58. I-F Transformers

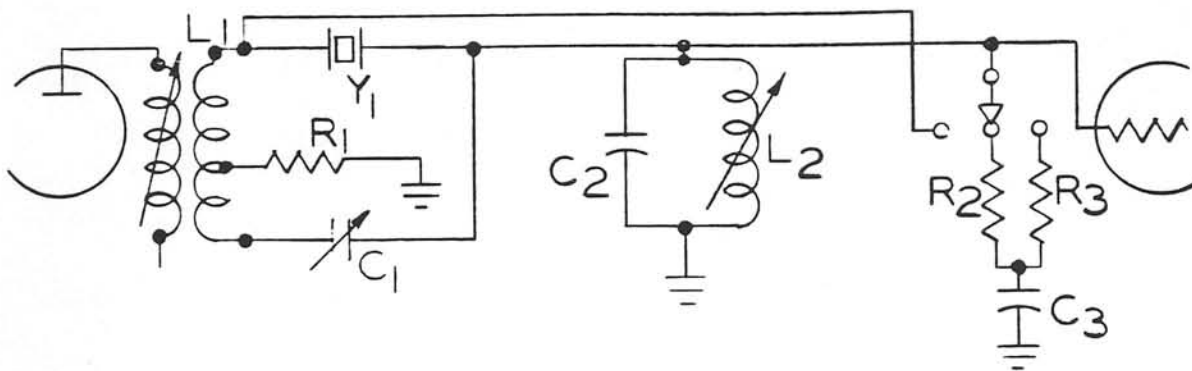

Figure 59. Crystal Filter Circuit

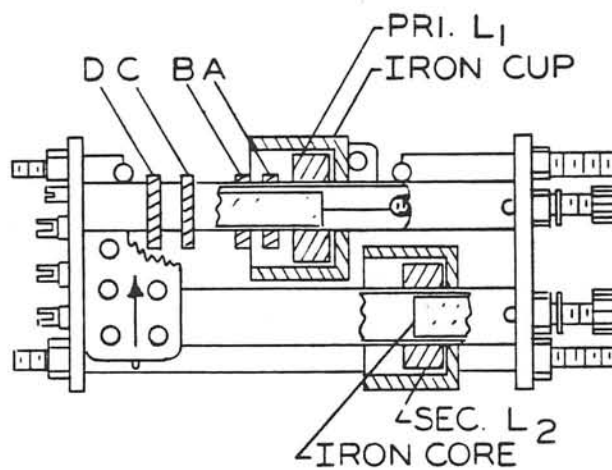

Figure 60. Interstage I-F Transformer

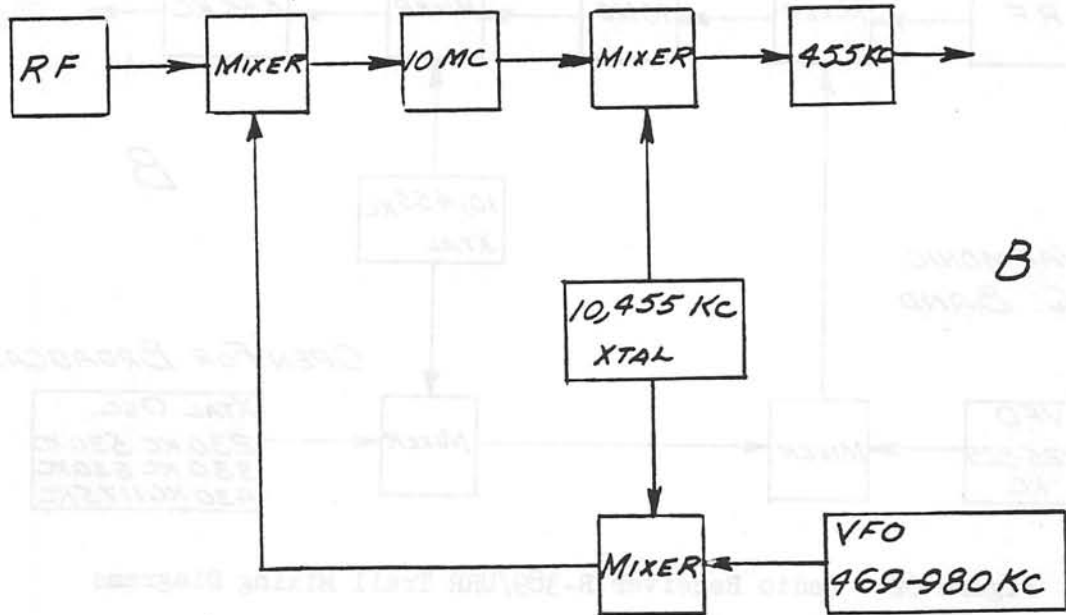
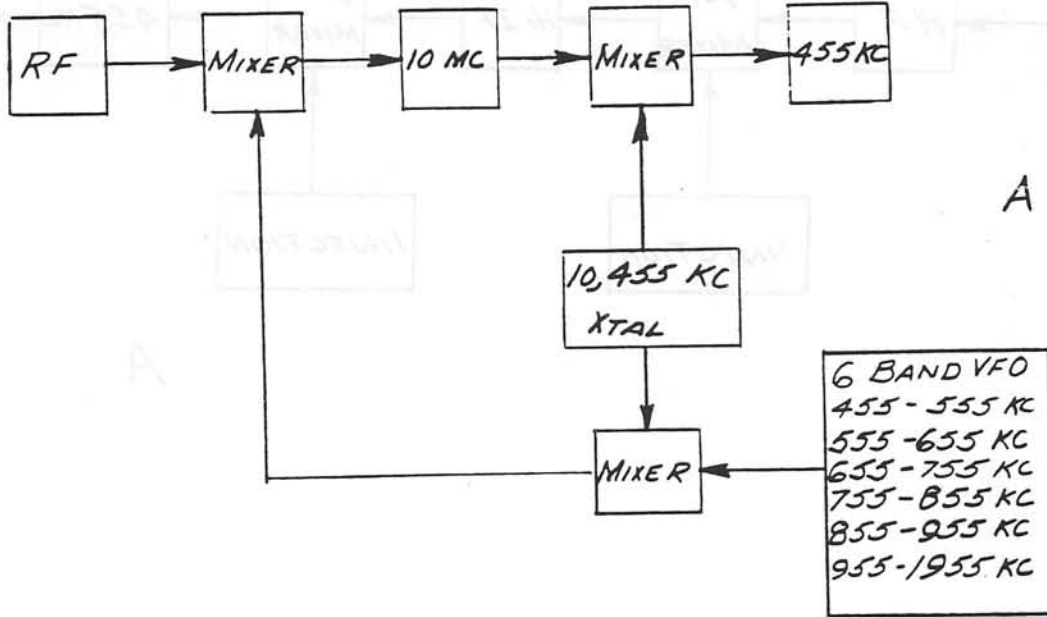

Figure 61. Radio Receiver R-389/URR Trail Mixing Diagrams



Courtesy of <http://BlackRadios.terryo.org>

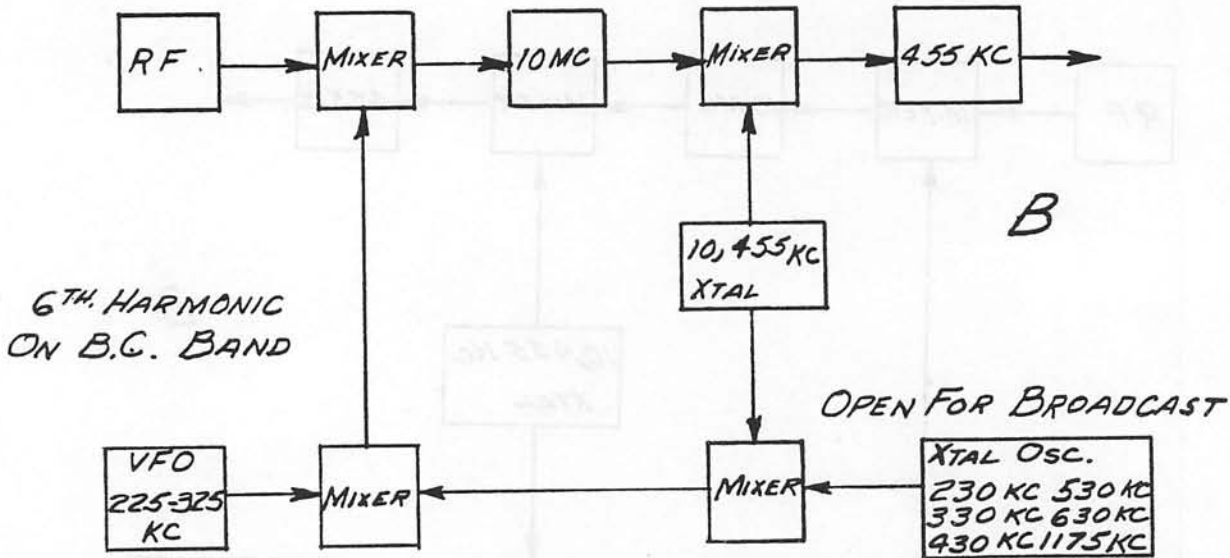
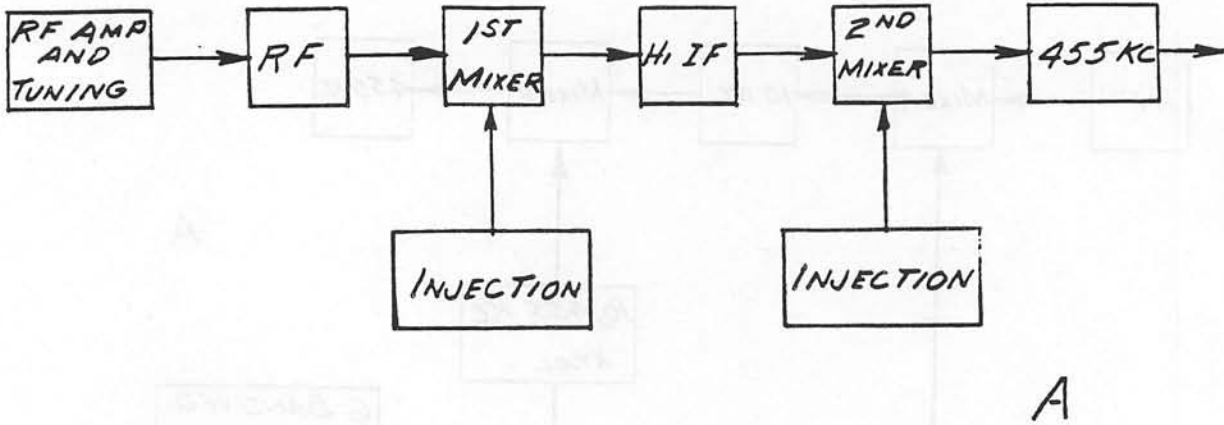

Figure 62. Radio Receiver R-389/URR Trail Mixing Diagrams

Courtesy of <http://BlackRadios.terryo.org>

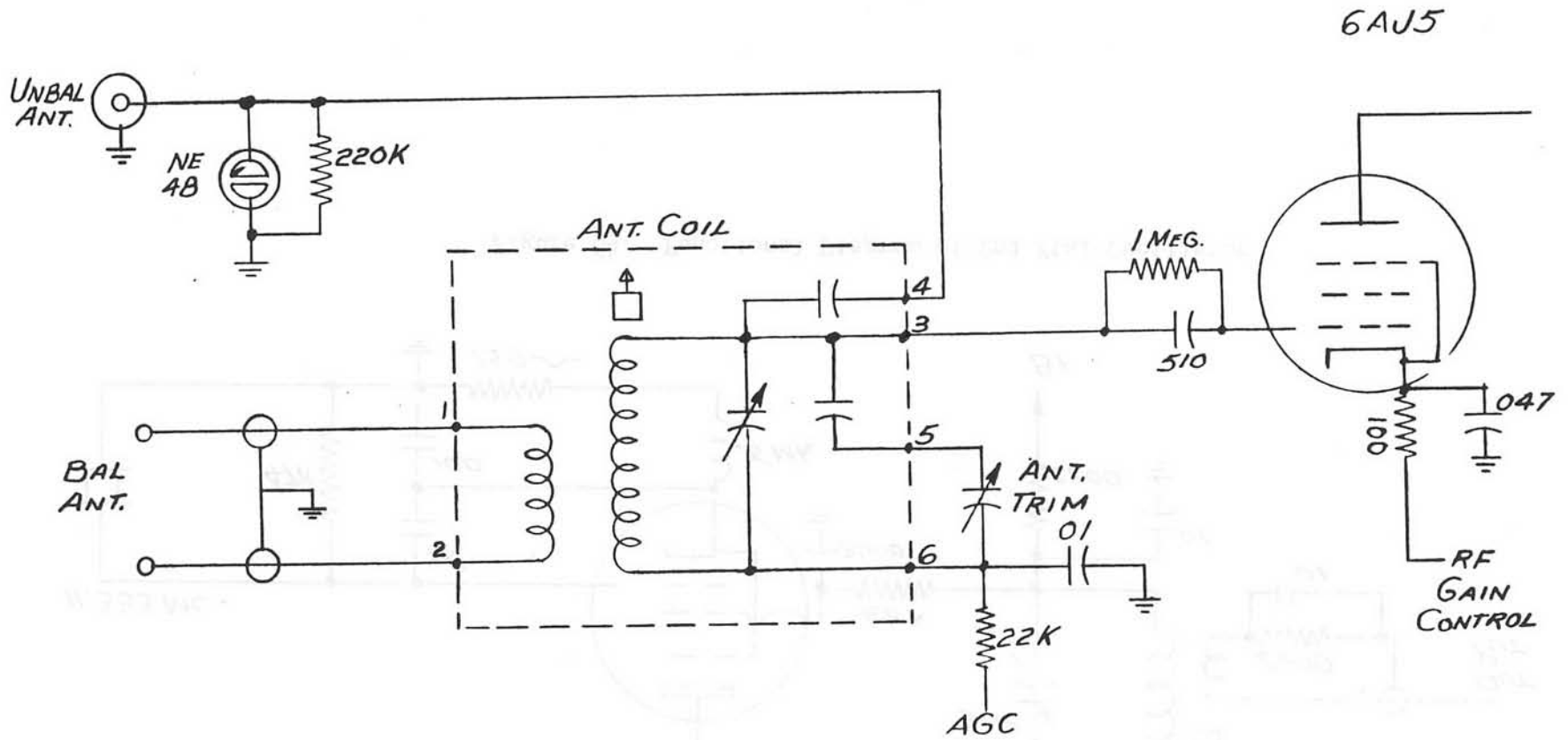

Figure 63. Functional Diagram of Ant. Input Circuit - R-390

RESTRICTED

SECURITY INFORMATION - RESTRICTED

Courtesy of <http://BlackRadios.terryo.org>

RESTRICTED

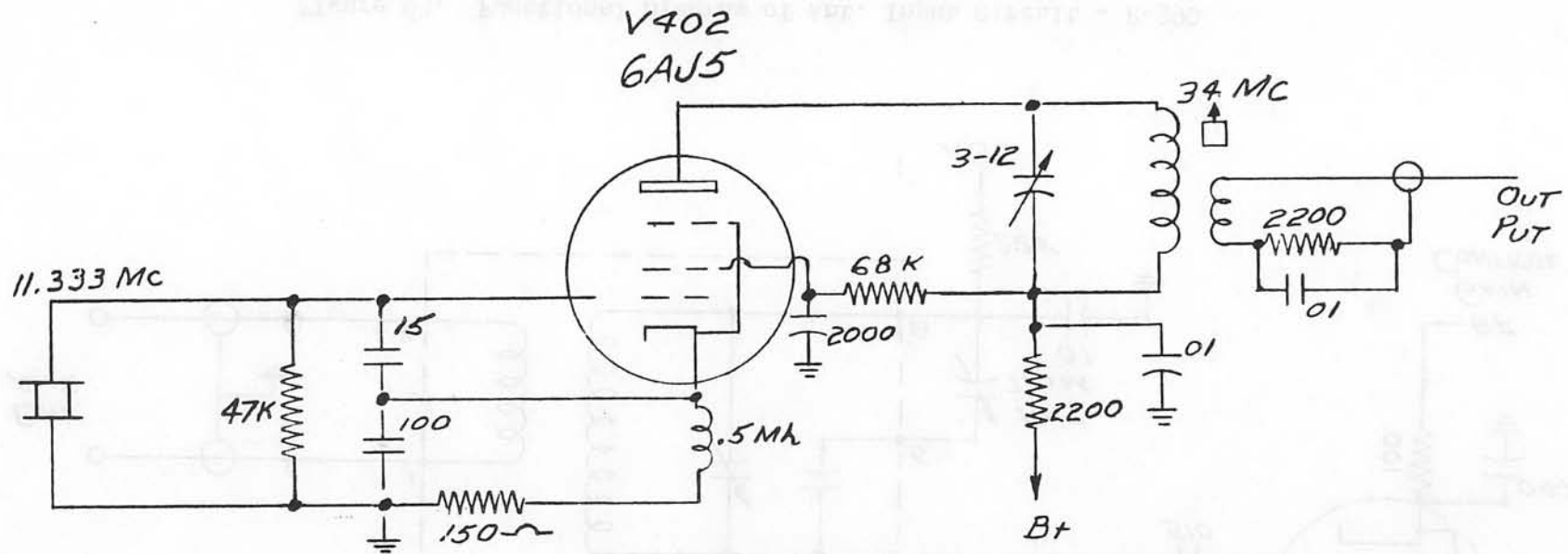

Figure 64. Functional Diagram of 2nd Xtal Oscillator

SECURITY INFORMATION - RESTRICTED

Courtesy of <http://BlackRadios.terry.org>

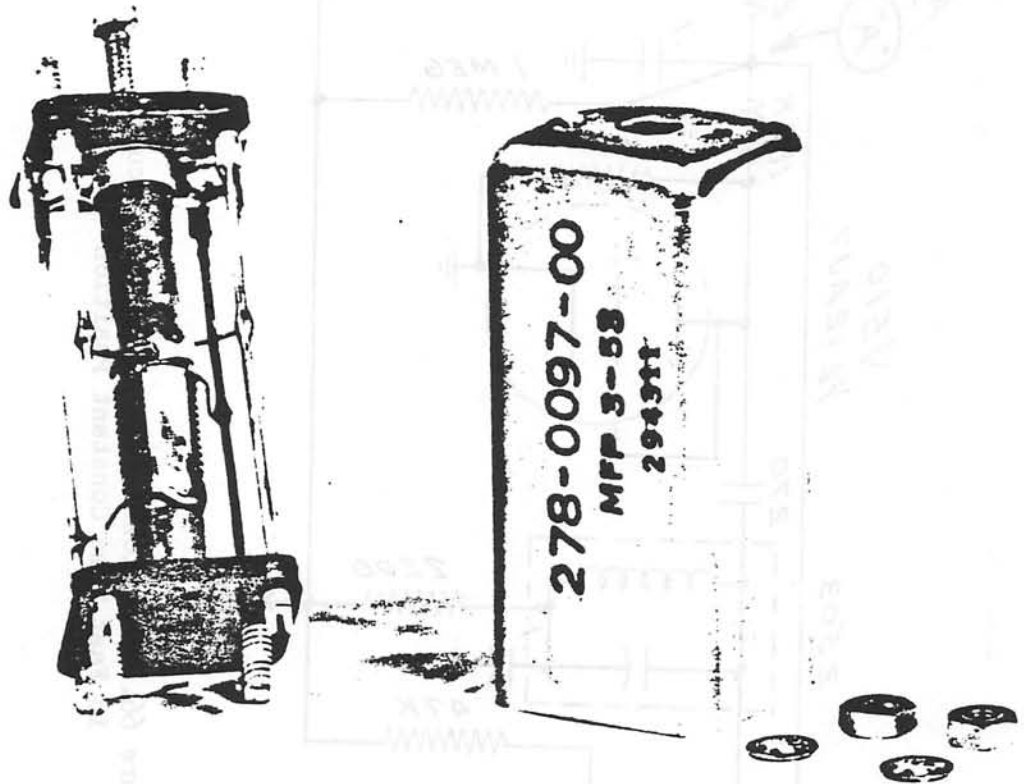

Figure 65. Crystal Oscillator Coil



Courtesy of <http://BlackRadios.terryo.org>

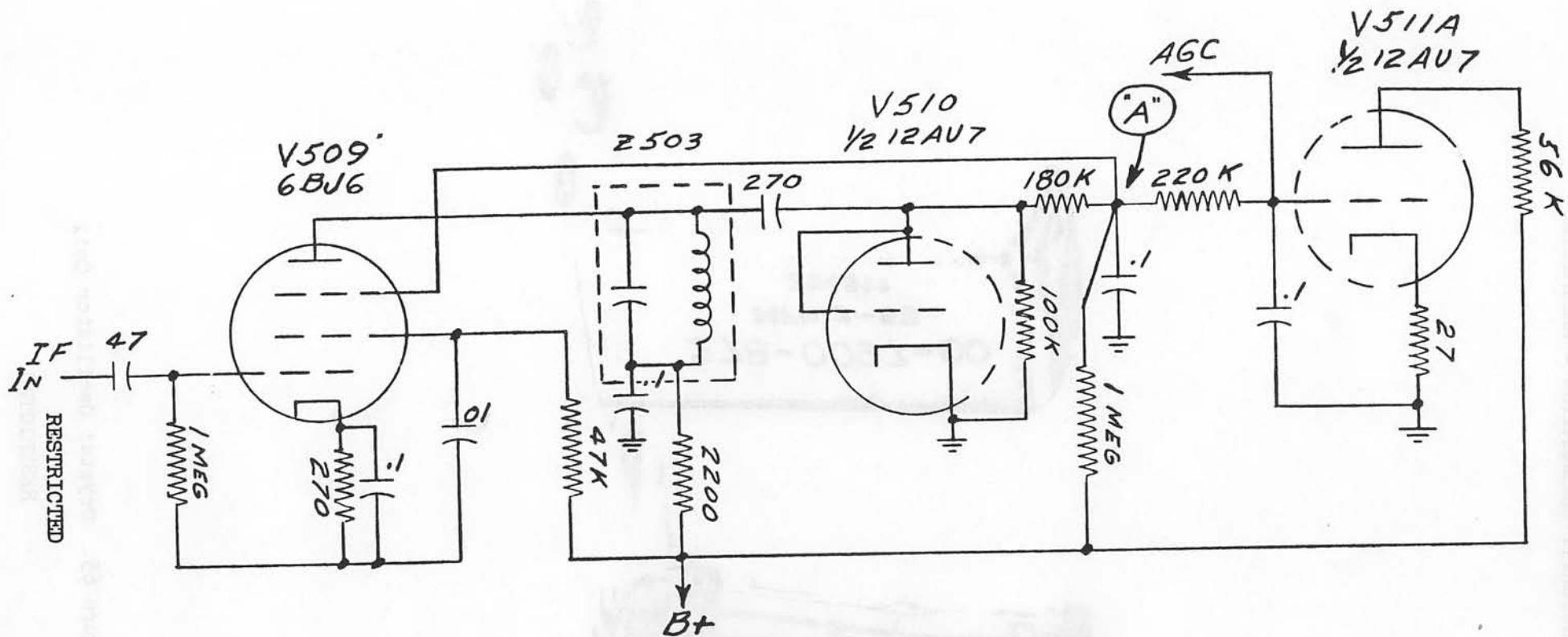

Figure 66. Functional Diagram of AGC Circuit in Fast Time Constant Position

Courtesy of <http://BlackRadios.terryo.org>

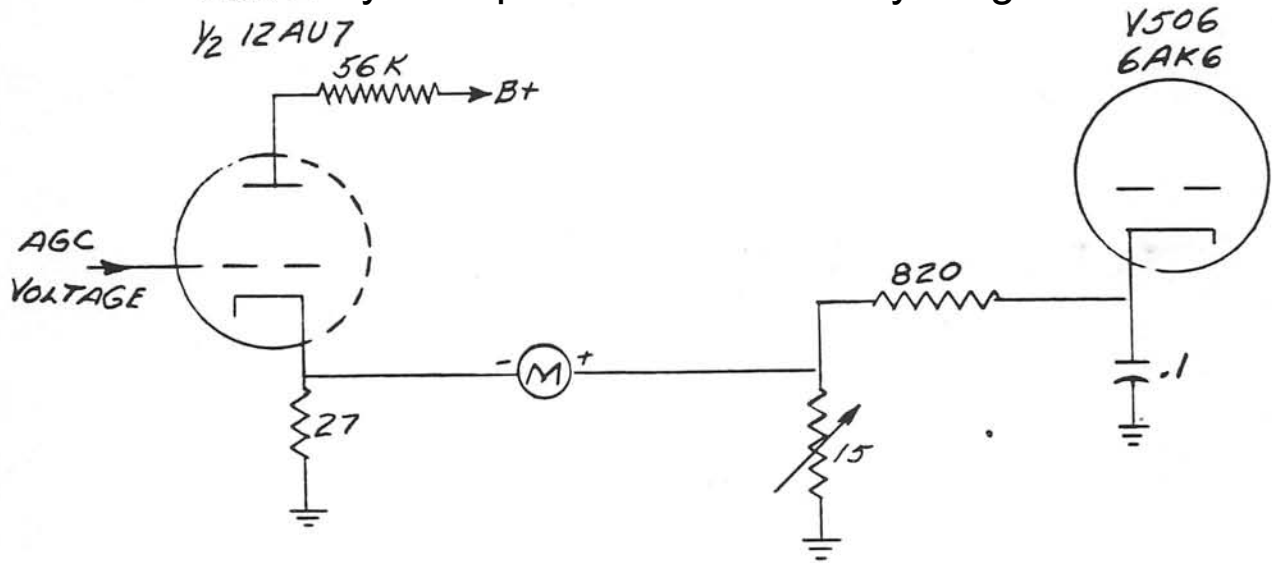

Figure 67. Carrier Level Meter Circuit

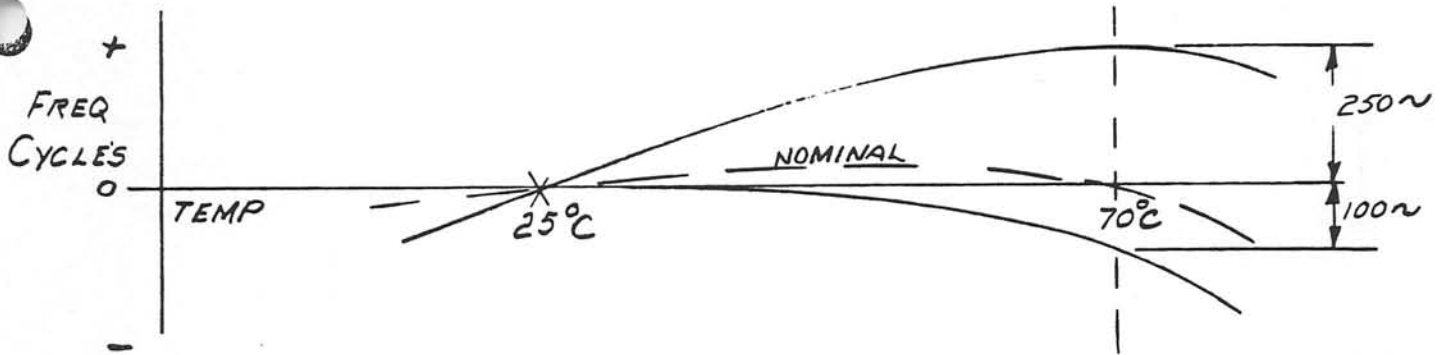

Figure 68. Frequency Change with 10 mmf T.C. Capacitor with T.C. Increment of 200 PPM and a 45°C Thermal Increment is 342 Cycles at 3.0 Mc.

Courtesy of <http://BlackRadios.terryo.org>

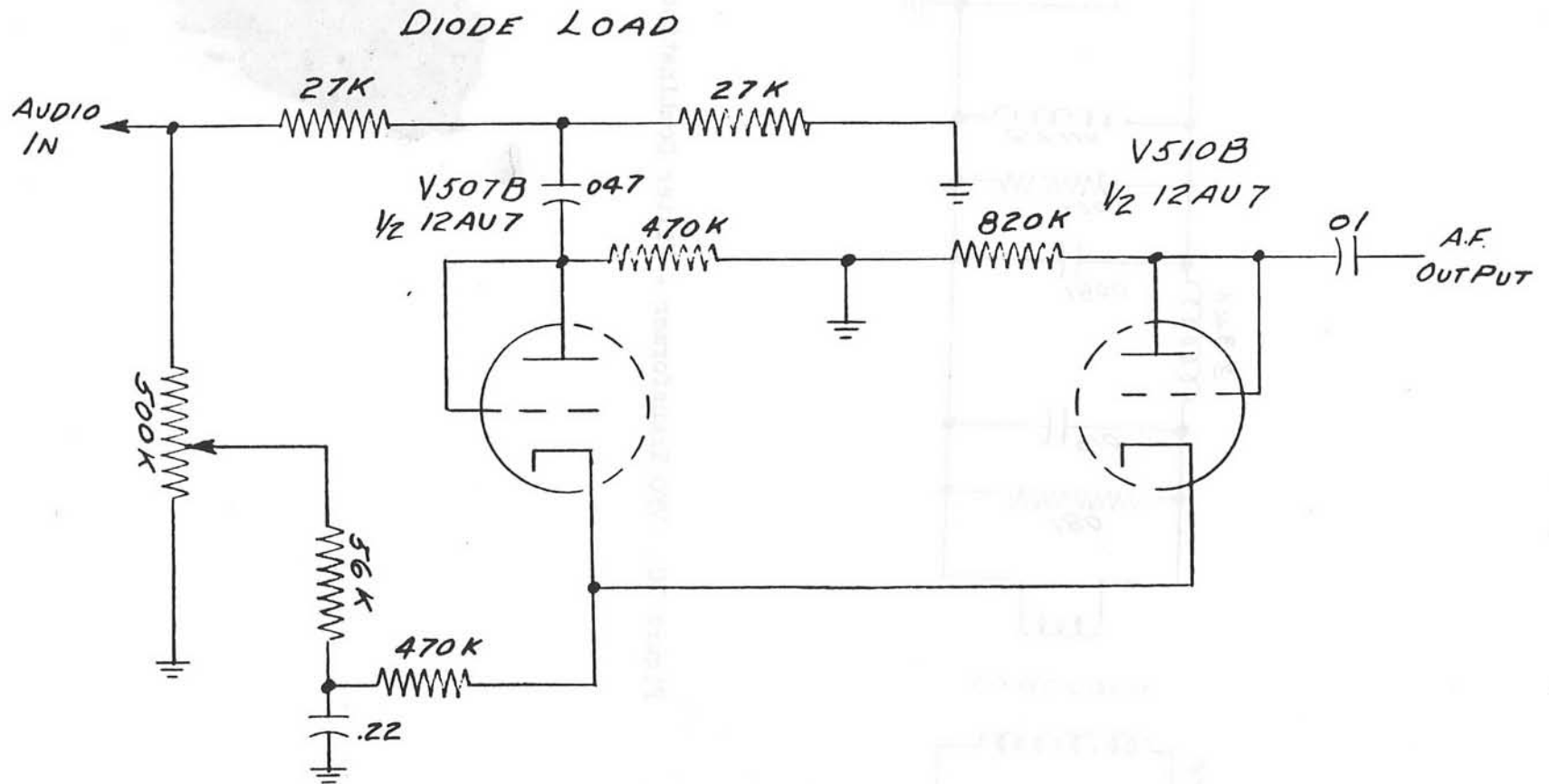

Figure 69. Functional Circuit Diagram of Noise Limiter in Operation

RESTRICTED

SECURITY INFORMATION - RESTRICTED

Courtesy of <http://BlackRadios.terryo.org>

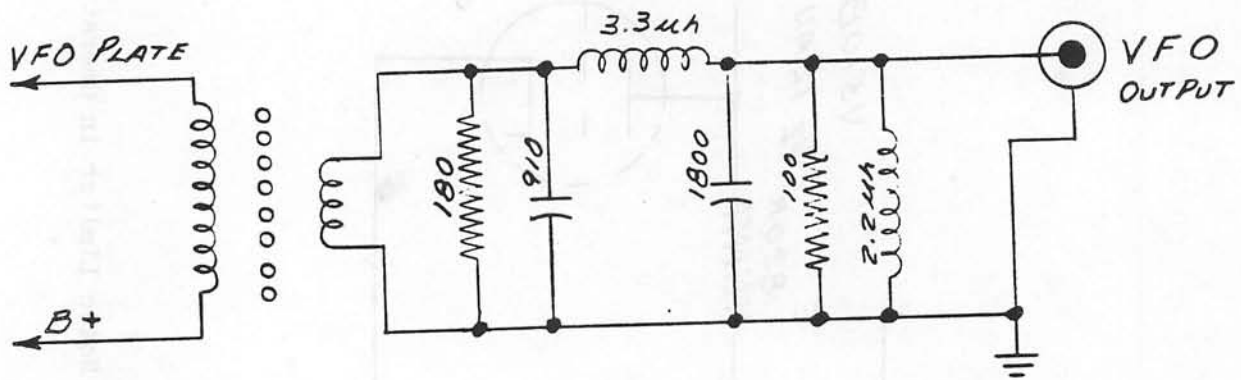

Figure 70. VFO Transformer - Filter Combination